

New product



TemTrip PRO

**MULTI-FUNCTIONAL PROTECTIVE RELAY
FOR HIGH/LOW-VOLTAGE CIRCUIT BREAKER**

PRS-1H series



The TemTrip PRO PRS-1H series of multi-functional protective relays for high or low-voltage circuit breakers display the load current pick-up or tripping with LEDs, and display circuit information such as phase current and line voltage on the LCD. There are three types available: generator protection, feeder circuit protection, and transformer protection.

Specifications	
Control voltage	24V DC / 110V DC
Power consumption	5VA
External dimensions(mm)	W196 × H146 × D163.6 (including the terminals on the back)
Operating temperature	-10°C ~ +55°C
Storage temperature	-25°C ~ +75°C
Humidity	95% or lower (no condensation)
Applicable standards	IEC60255-8

Measurement / event indication function				
Function		Presence / absence		
		For generator protection	For feeder circuit protection	For transformer protection
Measurement / event indication function	Current, voltage, electric power, frequency, power factor	○	○	○
	I/O state (contact)	○	○	○
	Harmonic measurement	△	△	△
	Trip event log (100 events)	○	○	○
	Alarm event log (100 events)	○	○	○
	Event log (200 events)	○	○	○
Monitoring function (4 to 20mA)		○	△	○

○ : Standard, △ : Optional

Protection/warning functions, etc.					
Function		ANSI / IEEE protective device number	Presence / absence		
			For generator protection	For feeder circuit protection	For transformer protection
Protective function	Long time-delay tripping (LT) * 3	51	○	○	○
	Short time-delay tripping (ST) * 3	50	○	○	○
	Instantaneous tripping (INST) * 3	50	○	○	○
	Undervoltage protection (UV) * 1	27	○	○	○
	Overvoltage protection (OV)	59	○	○	○
	Reverse power protection (RP) * 3	32R	○	—	—
	Ground fault overvoltage protection (OVGR)	64	○	○	○
	Directional ground fault protection (DGR)	67G	○	○	○
	Differential current protection (DIFF)	87	○	—	○
	Negative phase sequence current protection (UB)	46	○	○	○
	Underfrequency detection (UF) * 1	81U	○	—	—
	Overfrequency detection (OF)	81O	○	—	—
	Voltage establishment detection	84	○	—	—
	External trip	—	○	○	○
	Arc detection	—	△	△	△
Alarm function	Pre-trip alarm (PTA)	51P	○	○* 3	○* 3
	Pre-trip alarm 2 (PTA2)	51P	○	—	—
	System alarm (SYS)		○	○	○
Operation indication function	LED indicators, liquid crystal display (LCD), display and contact output		○	○	○
Monitoring function (4 to 20mA)			○	△	○
Communication function * 2			△	△	△
Control power supply			Required	Required	Required

○ : Standard, △ : Optional

- * 1 : Activated with auxiliary switch input terminals a and c short-circuited.
- * 2 : The communications protocol is Modbus RTU.
- * 3 : Capable of double settings. Two settings can be configured for each item, which can be switched by feeding a signal to input terminal cc-c.

Main features

- Uses a color graphical LCD

The display screen features a color graphical LCD that is 5-times larger than the screens of previous models for enhanced visibility.

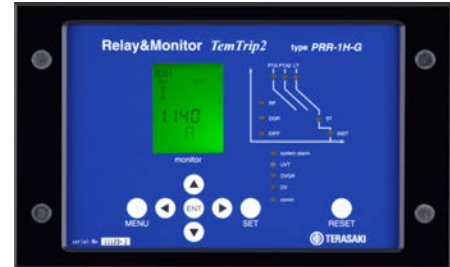

TemTrip2 (Current type)



TemTrip PRO

This also allows device states to be checked visually.

CB state	ON	OFF	
Earthing switch state	ON	OFF	
Power monitoring state * 1	Operating PM	Non-operating PM	
Double setting state	Protective function setting 1 selected DS	Protective function setting 2 selected DS	
Voltage establishment state * 1	Undetected G	Being detected (Blinking in green) G	Established (Lit in green) G
Connection type	Generator G	Motor M	Transformer E

* 1 : Only displayed for generator protection.

- Easy wiring

All input and output terminals use connectors as the connection method, making wiring much easier than previous models.

- Includes arc detection function (optional)

Arcing due to internal short circuits, circuit breaks or other causes are detected with an optical device to trigger an output. This allows issues that cannot be detected with currents or voltages to be identified much faster.

- Includes communication function (optional)

The communications function allows for transmission and centralized management of measured values or historical data. Modbus RTU is used as the communications protocol for easier system development.

External dimensions

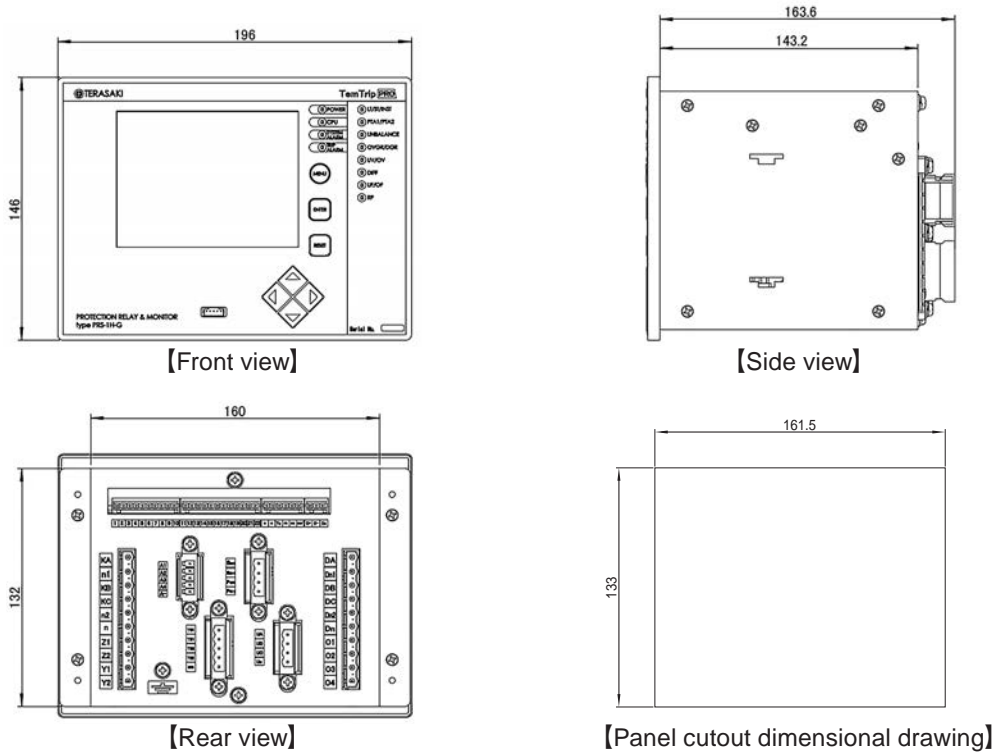

Ordering

PRS - 1H - - - - -

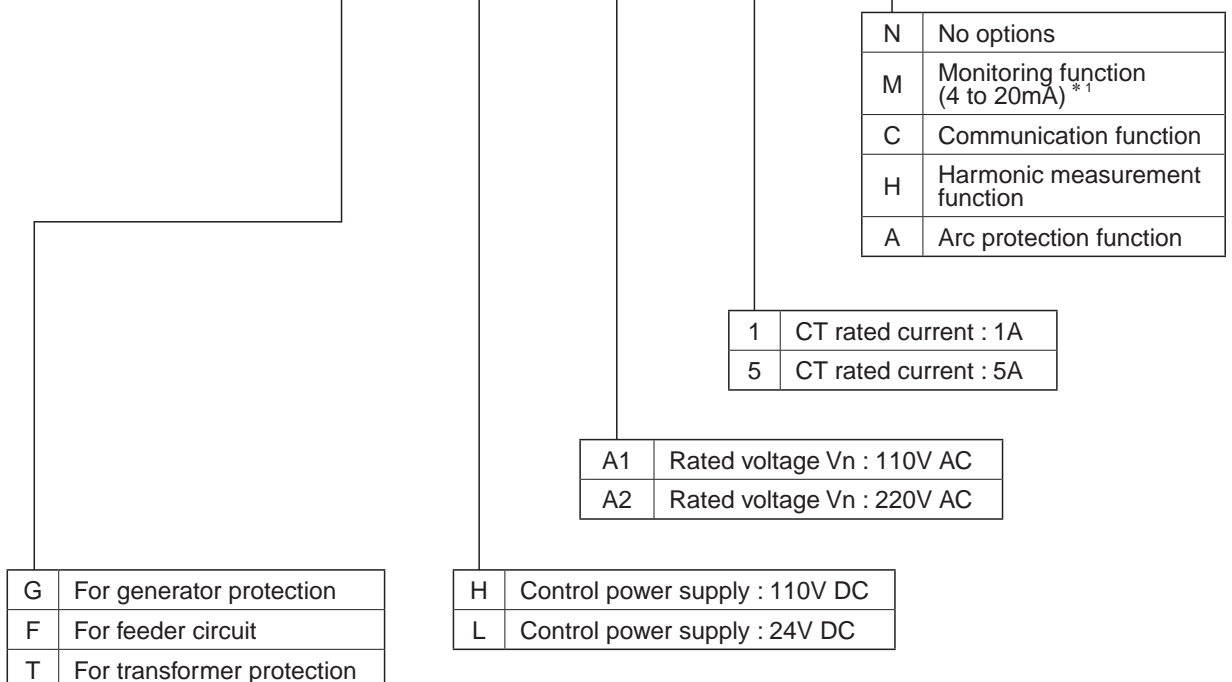

* 1 : Standard in models for generator protection and transformer protection.

For generator protection

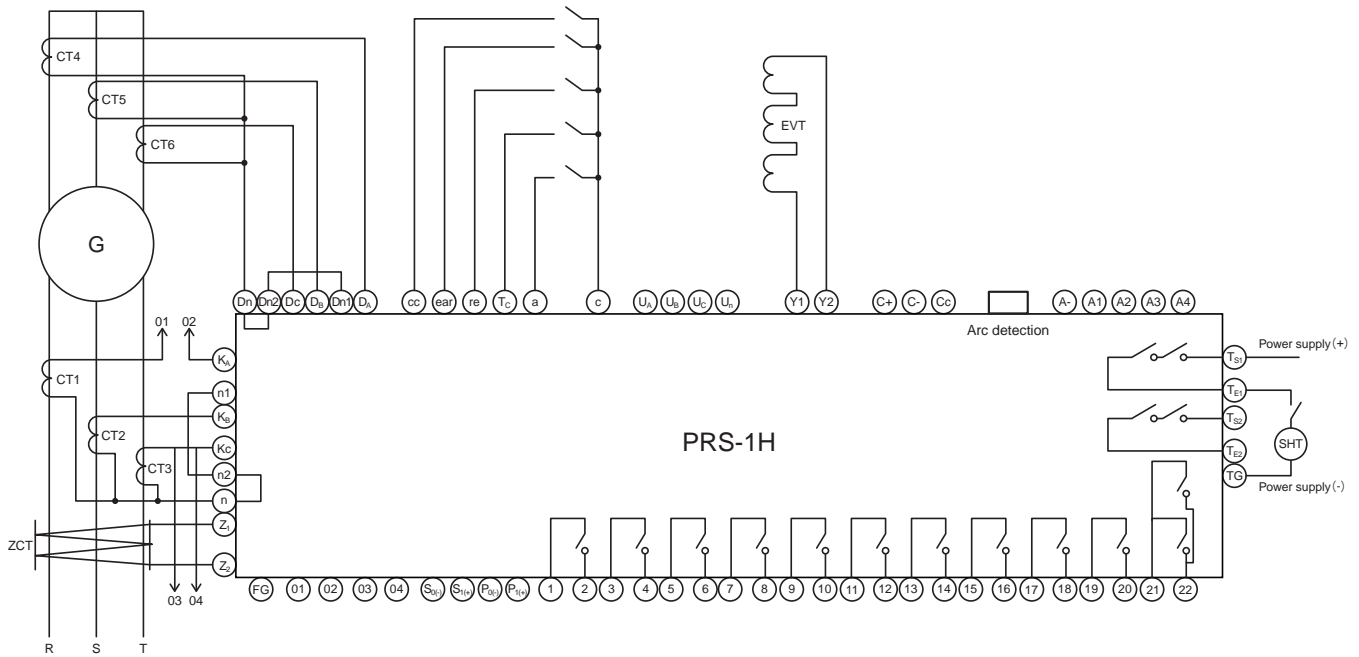

Signal input terminal

Terminal numbers	Terminal name
KA-n1 KB-n1 KC-n2	Protection: overcurrent detection CT
DA-n1 DB-n1 DC-n2	CT for differential current protection
Z1-Z2	ZCT
a-c	Auxiliary switch input
Tc-c	External trip signal input
re-c	Reset command input
ear-c	Earthing switch signal input
cc-c	Double setting switch input
UA,UB,UC	Rated voltage input
Y1-Y2	Zero phase voltage input
O1,O2,O3,O4	Monitoring : Current measurement

Power input terminal

Terminal numbers	Terminal name	Terminal name	Terminal name
S0(-) – S1(+)	Protective function	24V DC, 110V DC	
P0(-) – P1(+)	Monitoring function	24V DC, 110V DC	

Signal output terminal

Terminal numbers	Terminal name
A1 – A-	Output for monitoring function (4-20mA output 4 channels) * Select from current / voltage / active power / reactive power / frequency / power factor
A2 – A-	
A3 – A-	
A4 – A-	

Operation cause and alarm contact output terminal

Terminal numbers	Terminal name
1 – 2	Operation signal output * Operation signal output selection
3 – 4	Long time-delay tripping (LT/LT2), Short time-delay tripping (ST/ST2), Instantaneous tripping (INST/INST2),
5 – 6	Negative phase sequence current protection (UB), Directional ground fault (DGR), Ground fault overvoltage (OVGR),
7 – 8	Undervoltage (UV), Overvoltage (OV),
9 – 10	Differential current (DIFF), Reverse power (RP),
11 – 12	Underfrequency (UF), Overfrequency (OF), System alarm (SYS), Remote trip (RT),
13 – 14	Arc detection (ARC)
15 – 16	PTA operation signal output 1 (automatic reset)
17 – 18	PTA operation signal output 2 (automatic reset)
19 – 20	Lockout operation signal output
21 – 22	Self-diagnosis for monitoring function and protective function
TE1 – TS1	Trip output signal 1 (Pulse output)
TE2 – TS2	Trip output signal 2 (Pulse output)
C+	Communication signal output (+)
C-	Communication signal output (-)
Cc	Communication signal output (COMMON)
Arc detection	Dedicated connector

Wiring diagram

For feeder circuit

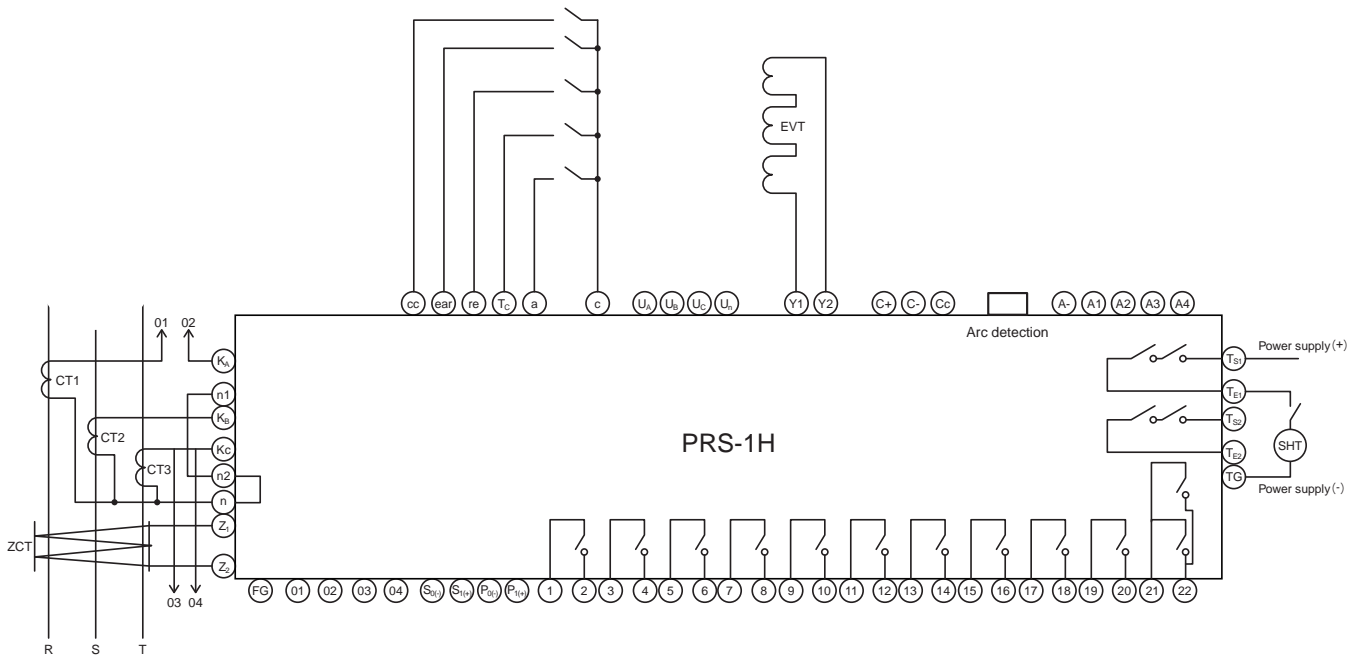

Signal input terminal

Terminal numbers	Terminal name
KA-n1 KB-n1 KC-n2	Protection: overcurrent detection CT
Z1-Z2	ZCT
a-c	Auxiliary switch input
Tc-c	External trip signal input
re-c	Reset command input
ear-c	Earthing switch signal input
cc-c	Double setting switch input
UA,UB,UC	Rated voltage input
Y1-Y2	Zero phase voltage input
O1,O2,O3,O4	Monitoring : Current measurement

Power input terminal

Terminal numbers	Terminal name	Terminal name	Terminal name
S0(-) – S1(+)	Protective function	24V DC, 110V DC	
P0(-) – P1(+)	Monitoring function	24V DC, 110V DC	

Signal output terminal

Terminal numbers	Terminal name
A1 – A-	Output for monitoring function (4-20mA output 4 channels) * Select from current / voltage / active power / reactive power / frequency / power factor
A2 – A-	
A3 – A-	
A4 – A-	

Operation cause and alarm contact output terminal

Terminal numbers	Terminal name	
1 – 2	Operation signal output * Operation signal output selection	
3 – 4	Long time-delay tripping (LT/LT2), Short time-delay tripping (ST/ST2), Instantaneous tripping (INST/INST2), Negative phase sequence current protection (UB), Directional ground fault (DGR), Ground fault overvoltage (OVGR), Undervoltage (UV), Overvoltage (OV), System alarm (SYS), Remote trip (RT), Arc detection (ARC)	
5 – 6		
7 – 8		
9 – 10		
11 – 12		
13 – 14		
15 – 16		PTA operation signal output (automatic reset)
17 – 18		Spare terminal
19 – 20		Lockout operation signal output
21 – 22		Self-diagnosis for monitoring function and protective function
TE1 – TS1	Trip output signal 1 (Pulse output)	
TE2 – TS2	Trip output signal 2 (Pulse output)	
C+	Communication signal output (+)	
C-	Communication signal output (-)	
Cc	Communication signal output (COMMON)	
Arc detection	Dedicated connector	

For transformer protection

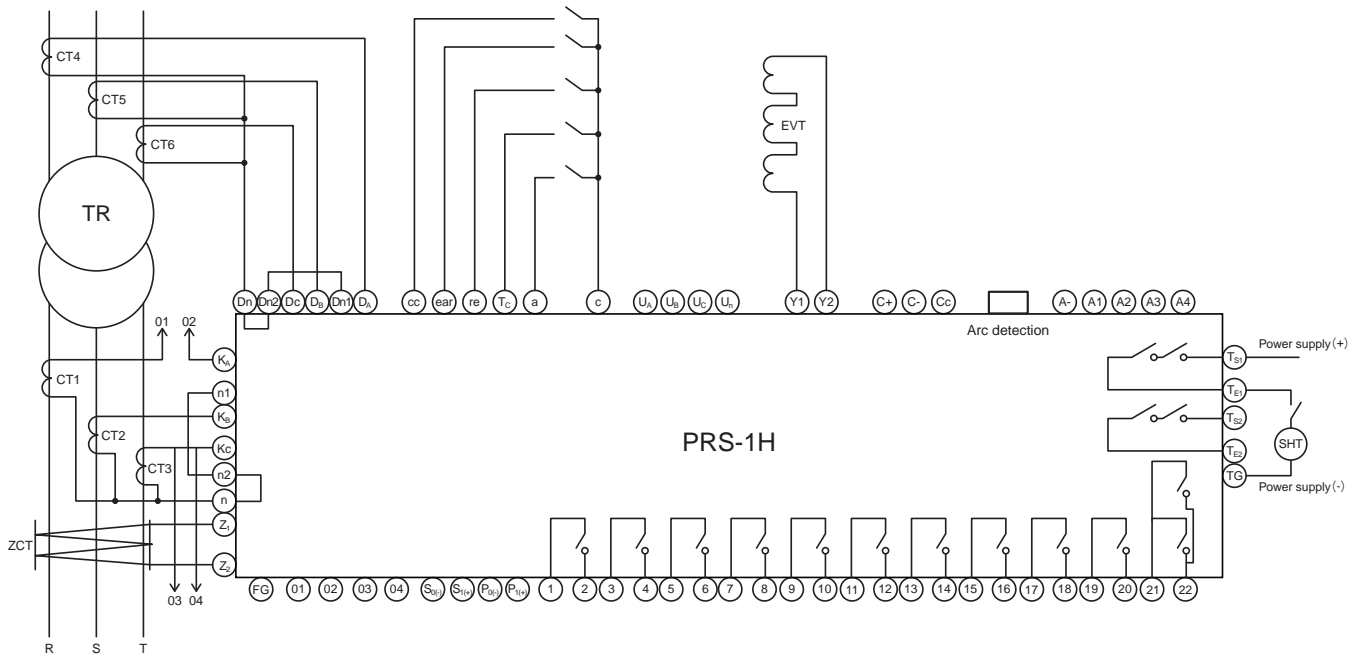

Signal input terminal

Terminal numbers	Terminal name
KA-n1 KB-n1 KC-n2	Protection: overcurrent detection CT
DA-n1 DB-n1 DC-n2	CT for differential current protection
Z1-Z2	ZCT
a-c	Auxiliary switch input
Tc-c	External trip signal input
re-c	Reset command input
ear-c	Earthing switch signal input
cc-c	Double setting switch input
UA,UB,UC	Rated voltage input
Y1-Y2	Zero phase voltage input
O1,O2,O3,O4	Monitoring : Current measurement

Power input terminal

Terminal numbers	Terminal name
S0(-) – S1(+)	Protective function 24V DC, 110V DC
P0(-) – P1(+)	Monitoring function 24V DC, 110V DC

Signal output terminal

Terminal numbers	Terminal name
A1 – A-	Output for monitoring function (4-20mA output 4 channels) * Select from current / voltage / active power / reactive power / frequency / power factor
A2 – A-	
A3 – A-	
A4 – A-	

Operation cause and alarm contact output terminal

Terminal numbers	Terminal name
1 – 2	Operation signal output * Operation signal output selection
3 – 4	Long time-delay tripping (LT/LT2), Short time-delay tripping (ST/ST2), Instantaneous tripping (INST/INST2), Negative phase sequence current protection (UB), Directional ground fault (DGR), Ground fault overvoltage (OVGR), Undervoltage (UV), Overvoltage (OV), Differential current (DIFF), System alarm (SYS), Remote trip (RT), Arc detection (ARC)
5 – 6	
7 – 8	
9 – 10	
11 – 12	
13 – 14	
15 – 16	PTA operation signal output (automatic reset)
17 – 18	Spare terminal
19 – 20	Lockout operation signal output
21 – 22	Self-diagnosis for monitoring function and protective function
TE1 – TS1	Trip output signal 1 (Pulse output)
TE2 – TS2	Trip output signal 2 (Pulse output)
C+	Communication signal output (+)
C-	Communication signal output (-)
Cc	Communication signal output (COMMON)
Arc detection	Dedicated connector

MEMO

A series of horizontal dotted lines for writing, spanning the width of the page.

 **Safety Notice**

Carefully read instruction manual to ensure proper installation, connection, operation, handling and maintenance of the product.

 **TERASAKI ELECTRIC CO., LTD.**

Head Office: 6-13-47 Kamihigashi, Hirano-ku, Osaka 547-0002, Japan

Circuit Breaker Division: 6-13-47 Kamihigashi, Hirano-ku, Osaka 547-0002, Japan

TEL +81-6-6791-2763

FAX +81-6-6791-2732

int-sales@terasaki.co.jp

<http://www.terasaki.co.jp/>