

DC Air Circuit Breakers Moulded Case Circuit Breakers

TemPower & TemBreak



TERASAKI ELECTRIC CO., LTD.

www.terasaki.co.jp

CAT REF. '18-I73E

TABLE OF CONTENTS

1. General1-1

Introduction	1-2
General	1-3
Selection Chart	1-4

2. Ratings and Specifications2-1

Air Circuit Breakers for DC350V-800V	2-2
Moulded Case Circuit Breakers for DC350V-600V	2-3
Moulded Case Circuit Breakers for DC750V-1000V	2-5
Switch-disconnectors for DC600V-1000V	2-8

3. Characteristics3-1

Time/Current characteristic curves, Ambient Compensating Curves S160-SD, S160-GD, PVE160-SDL, S250-SD, S250-GD 3P	3-2
S400-ND, S800-ND 3P	3-3
S1000-ND 2P, 3P	3-3
XS1250ND, XS1600ND, XS2000ND 2P, 3P	3-4
XS2500ND, XS3200ND 2P, 3P	3-5
PVS160-SDL, PVS250-SDL 3P	3-6
PVS160-SDH, PVS250-SDH 4P	3-6
PVS160-GDH, PVS250-GDH 4P	3-6
PVS400-NDL 3P	3-6
PVS400-NDL, PVS400-NDH, PVS800-NDH 4P	3-7
PVS800-NDL 3P, 4P	3-7

4. Mounting and Connection4-1

Connection of conductors to DC circuit breakers	4-2
Insulation distance DC600V or less	4-7
Insulation distance DC750V-1000V PVE160-SDL 3P	4-8
PVS160-SDL 3P, PVS250-SDL 3P, PVS250-SNL 3P	4-9
PVS160-SNL 4P, PVS250-SNL 4P	4-10
PVS160-GDH 4P, PVS250-GDH 4P	4-11
PVS160-SDH 4P, PVS250-SDH 4P	4-12
PVS160-SNH 4P, PVS250-SNH 4P	4-13
PVS400-NDL 3P	4-14
PVS400-NDL 4P, PVS400-NDH 4P	4-15
PVS400-NNL 3P	4-16
PVS400-NNL 4P, PVS400-NNH 4P	4-17
PVS800-NDL 3P	4-18
PVS800-NDL 4P, PVS800-NDH 4P	4-19
PVS800-NNL 3P	4-20
PVS800-NNL 4P, PVS800-NNH 4P	4-21

5. Accessories5-1

Internally mounted accessories 1. Connection diagrams and terminal numbers	5-2
2. Possible combinations	5-3
3. Ratings data of auxiliary and alarm switches	5-4
4. Shunt trip device (SH)	5-4
5. Undervoltage trip device (UV)	5-4
Externally mounted accessories 1. Motor operators (MC)	5-6
2. External operating handles	5-12
(1) Breaker-mounted (field installable small type) (HB)	5-12
(2) Door-mounted (depth adjustable) (HP)	5-20
3. Toggle holder (HH) and toggle lock (HL)	5-27
4. Terminal covers	5-28
5. Terminal blocks (TF)	5-32

6. Outline Dimensions6-1

DC Air Circuit Breakers Outline Dimensions AR208S, AR212S, AR216S, AR220S 3P	6-2
AR325S, AR332S 3P	6-4
AR325-NDH 4P	6-6
AR440S 3P	6-8
DC Moulded Case Circuit Breakers Outline Dimensions S160-SD, S160-GD, S160-SDN, S250-SD, S250-GD, S250-SDN 3P	6-10
S400-ND 3P	6-11
S800-ND 3P	6-11
S1000-ND 2P, 3P	6-12
XS1250ND 2P, 3P	6-13
XS1600ND 2P, 3P	6-14
XS2000ND 2P, 3P	6-15
XS2500ND, XS3200ND 2P, 3P	6-16
PVE160-SDL 3P	6-17
PVS160-SDL, PVS250-SDL 3P	6-18
PVS250-SNL 3P	6-18
PVS160-SNL, PVS250-SNL 4P	6-19
PVS160-GDH, PVS250-GDH 4P	6-19
PVS160-SDH, PVS250-SDH, PVS160-SNH, PVS250-SNH 4P	6-20
PVS400-NDL 3P	6-21
PVS400-NDL, PVS400-NDH 4P	6-21
PVS400-NNL 3P	6-22
PVS400-NNL, PVS400-NNH 4P	6-22
PVS800-NDL 3P	6-23
PVS800-NDL, PVS800-NDH 4P	6-23
PVS800-NNL 3P	6-24
PVS800-NNL, PVS800-NNH 4P	6-24

1

General

Introduction	1-2
General	1-3
Selection Chart	1-4

Introduction

In recent years, as part of the drive to reduce greenhouse gas emissions, significant attention is now being directed towards the energy produced by large-scale photovoltaic (solar), wind, and biomass energy power generation.

The total power generation capacity of facilities for these new energy sources is expected to exceed that produced by nuclear energy by approximately 2030. To aid and support these new technologies, Terasaki now offer a new, broad range of dedicated DC air circuit breakers and moulded case circuit breakers. The new range of Terasaki DC circuit breakers are ideally suited for all types of industries, buildings, as well as the information technology and communications sectors where highly reliable sources of electric power are required.

DC Air Circuit Breakers



AR220S

Rated current 2000A
Rated breaking capacity DC600V 40kA

Possible reverse connection

DC Moulded Case Circuit Breakers



PVE160-SDL

Rated current 160A
Rated breaking capacity DC750V 3kA

Possible reverse connection



PVS160-SDL

Rated current 160A
Rated breaking capacity DC750V 5kA

Possible reverse connection



PVS250-SDH

Rated current 250A
Rated breaking capacity DC1000V 5kA

Possible reverse connection

DC power sources for the Uninterruptible Power Supply (UPS) market

Electrical and electronic equipment used in the advanced information and communications sectors requires a highly reliable power source. Should a power failure occur, and to assist with continuity of electrical power, it is standard practice to install an Uninterruptible Power Supply (UPS).

A data centre is where Internet servers and other systems for data communications, such as fixed, mobile, and IP telephones are installed. At the data centre, AC power from the main system power source is sent to the UPS, and is temporarily converted to DC power. A storage battery is then charged with this DC power, which is re-converted back into AC power and then sent to the information equipment.

Building and Industrial power back-up

A UPS is typically required for critical power systems in department stores, hotels, hospitals, theaters, and office buildings. For example, in semiconductor manufacturing plants that feature advanced automation as a part of their production processes, UPS systems with large battery capacities are used to take measures against any large-scale power outage affecting critical manufacturing facilities.

Photovoltaic power generation

Photovoltaic (or Solar) power generation, which is attracting attention as clean energy, ranges from simple generation of up to several kilowatts for home use, to larger systems of 100 kilowatts or greater for industrial use. In the "School New Deal" program, one of the governmental measures during the economic crisis, were for eco-friendly modifications which advocated the use of photovoltaic power generation at schools. One example is a power distribution system linked to a source of photovoltaic power generation. The current produced from the photovoltaic solar cells is sent to a power conditioner via a diode with a DC circuit breaker in a junction box and then converted into AC, which can then be supplied to a load via a distribution board.

Rationalization of use of electric power via large-capacity storage battery

Energy from new power sources such as wind and photovoltaic power generation do not have a stable output. A lithium ion battery and a sodium-sulfur (NAS) battery can suppress such fluctuations by load leveling. The battery is charged at night using a lower electrical power rate at night and discharged at daytime when the electrical power usage rate is higher, and in addition, any new electrical power generated can also be saved. For this purpose, large-capacity storage battery systems are used at wind and photovoltaic power generation facilities. The use of these types of systems is expected to grow across all user sectors requiring large amounts of power, plus as an additional measure against possible power outages.

All Air Circuit Breakers and Switch-disconnectors are possible to reverse the connection.
 Moulded Case Circuit Breakers up to 1000A frame are possible to reverse the connection.

Selection Chart

Voltage		Frame size (A)						
		160	250	400	800			
Air Circuit Breakers	800V							
	600V				AR208S 3P 40kA/40kA			
Moulded Case Circuit Breakers	1000V	PVS160-SDH 4P 5kA/5kA		PVS250-SDH 4P 5kA/5kA	PVS400-NDH 4P 10kA/5kA	PVS800-NDH 4P 10kA/5kA		
		PVS160-GDH 4P 10kA/5kA		PVS250-GDH 4P 10kA/5kA				
	750V	PVE160-SDL 3P 3kA/3kA	PVS160-SDL 3P 10kA/5kA		PVS250-SDL 3P 10kA/5kA	PVS400-NDL 3P 10kA/5kA	PVS800-NDL 3P 10kA/10kA	
					PVS400-NDL 4P 10kA/10kA	PVS800-NDL 4P 10kA/10kA		
	600V	S160-SD 3P 5kA/5kA	S160-GD 3P 10kA/5kA	S250-SD 3P 5kA/5kA	S250-GD 3P 10kA/5kA	S400-ND 3P 15kA/15kA	S800-ND 3P 20kA/10kA	
	500V	S160-SD 3P 7.5kA/7.5kA	S160-GD 3P 15kA/7.5kA	S250-SD 3P 7.5kA/7.5kA	S250-GD 3P 15kA/7.5kA			
	350V	S160-SD 3P 10kA/10kA		S250-SD 3P 10kA/10kA		S400-ND 3P 20kA/20kA	S800-ND 3P 30kA/15kA	
	250V							
	Switch-disconnectors	1000V		PVS160-SNH 4P		PVS250-SNH 4P	PVS400-NNH 4P	PVS800-NNH 4P
		800V		PVS160-SNL 4P		PVS250-SNL 4P	PVS400-NNL 4P	PVS800-NNL 4P
		750V			PVS250-SNL 3P	PVS400-NNL 3P	PVS800-NNL 3P	
600V		S160-SDN 3P		S250-SDN 3P				



... Reverse connection Possible



... Reverse connection Not possible

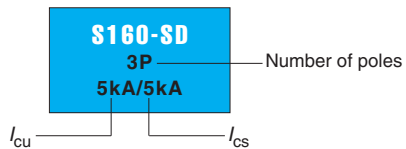

1000

1250

1600

2000

2500

3200

4000

AR325-NDH
4P
30kA/30kA

AR212S
3P
40kA/40kA

AR216S
3P
40kA/40kA

AR220S
3P
40kA/40kA

AR325S
3P
40kA/40kA

AR332S
3P
40kA/40kA

AR440S
3P
40kA/40kA

S1000-ND
3P
20kA/10kA

XS1250ND
3P
20kA/15kA

XS1600ND
3P
20kA/15kA

XS2000ND
3P
20kA/15kA

XS2500ND
3P
20kA/15kA

XS3200ND
3P
20kA/15kA

S1000-ND
3P
30kA/15kA

XS1250ND
3P
50kA/25kA

XS1600ND
3P
50kA/25kA

XS2000ND
3P
50kA/25kA

XS2500ND
3P
50kA/25kA

XS3200ND
3P
50kA/25kA

S1000-ND
2P
50kA/20kA

XS1250ND
2P
50kA/30kA

XS1600ND
2P
50kA/30kA

XS2000ND
2P
50kA/30kA

XS2500ND
2P
50kA/30kA

XS3200ND
2P
50kA/30kA

2

Ratings and Specifications

Air Circuit Breakers for DC350V-800V	2-2
Moulded Case Circuit Breakers for DC350V-600V	2-3
Moulded Case Circuit Breakers for DC750V-1000V	2-5
Switch-disconnectors for DC600V-1000V	2-8

Air Circuit Breakers for DC350V-800V

Frame size (A)	800	1250	1600	2000	2500	2500	3200	4000	
Type	AR208S	AR212S	AR216S	AR220S	AR325S	AR325-NDH	AR332S	AR440S	
Rated current (max.) [I_n] A	800	1250	1600	2000	2500	2500	3200	4000	
Number of poles	3	3	3	3	3	4	3	3	
Rated insulation voltage [U_i] V	1000	1000	1000	1000	1000	1000	1000	1000	
Rated operational voltage [U_e] V	DC 600	600	600	600	600	800	600	600	
Rated impulse withstand voltage [U_{imp}] kV	12	12	12	12	12	12	12	12	
Rated breaking cap, kA									
JIS C 8201-2-1 Ann.1 Ann.2	DC 800V	—	—	—	—	30/30	—	—	
IEC 60947-2	600V	40/40	40/40	40/40	40/40	—	40/40	40/40	
I_{cu}/I_{cs} ①②	500V	40/40	40/40	40/40	40/40	—	40/40	40/40	
	350V	40/40	40/40	40/40	40/40	—	40/40	40/40	
Rated short time withstand current [I_{cw}] kA	1s 40	40	40	40	40	30	40	40	
Latching current kA	65	65	65	65	85	85	85	100	
Total breaking time (s)	0.04	0.04	0.04	0.04	0.04	0.04	0.04	0.04	
Closing operation time									
Spring charging time (s) max.	10	10	10	10	10	10	10	10	
Close time (s) max.	0.08	0.08	0.08	0.08	0.08	0.08	0.08	0.08	
No. of operating cycles									
Mechanical life	with maintenance	30000	30000	30000	25000	20000	20000	15000	
	without maintenance	15000	15000	15000	12000	10000	10000	8000	
Electrical life	without maintenance DC 600V	1000	1000	1000	1000	500	500	500	
Outline dimension mm									
Draw-out type	a	354	354	354	354	460	580	460	631
	b	460	460	460	460	460	460	460	460
	c	345	345	345	345	345	345	345	375
	d	40	40	40	40	40	40	40	53
Weight kg	76	76	76	79	105	125	105	139	
Reverse connection	Yes	Yes	Yes	Yes	Yes	Yes	Yes	Yes	

Notes:

— : "no" or "not available".

① : AGR over-current release can not be used for DC. Please prepare DC over-current relay and connect with shunt trip device.

② : The time constant (L/R) of the circuit should be,

less than 2.0ms nearby rated current
less than 15ms for short circuit

(1) Shunt trip device is Instantaneously rated type. Continuously rated shunt trip device is not applicable.

(2) Undervoltage trip device is not applicable.

(3) Test jumper is not applicable.

For further details please contact TERASAKI.

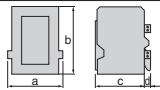

Moulded Case Circuit Breakers for DC350V-600V

Frame size (A)	160	160	250	250	400	800	1000
Type	\$160-SD	\$160-GD	\$250-SD	\$250-GD	\$400-ND	\$800-ND	\$1000-ND
Number of poles	3	3	3	3	3	3	2* 3
■ Ratings							
Rated current, A	25 (16-25)	25 (16-25)	100 (63-100)	100 (63-100)	250 (160-250)	630 (400-630)	1000
Calibrated at 45°C	32 (20-32)	32 (20-32)	125 (80-125)	125 (80-125)	400 (250-400)	800 (500-800)	
	40 (25-40)	40 (25-40)	160 (100-160)	160 (100-160)			
	63 (40-63)	63 (40-63)	200 (125-200)	200 (125-200)			
	80 (50-80)	80 (50-80)	250 (160-250)	250 (160-250)			
	100 (63-100)	100 (63-100)					
	125 (80-125)	125 (80-125)					
	160 (100-160)	160 (100-160)					
* 2 poles breaker is same outline dimensions as 3 poles breaker.							
Rated insulation voltage [U _i] V	690	690	800	800	800	800	800
Rated impulse withstand voltage [U _{imp}] kV	8	8	8	8	8	8	8
■ Rated breaking capacity, kA							
JIS C 8201-2-1 Ann.1 Ann.2 DC	5/5	10/5	5/5	10/5	15/15	20/10	— 20/10
IEC 60947-2	7.5/7.5	15/7.5	7.5/7.5	15/7.5	15/15	20/10	— 20/10
I _{cu} /I _{cs} (4) (5)	10/10	—	10/10	—	20/20	30/15	— 30/15
	—	—	—	—	—	—	50/20
	—	—	—	—	—	—	—
■ External dimensions, mm							
	a	a	105	105	140	210	210
	b	b	165+55 (17)	165+55 (17)	260	273	273
	c	c	68	68	103	103	103
	d	d	95	95	145	145	145
Weight (● marked standard type) kg	0.8	0.8	1.5	1.5	4.2	8.5	9.8 10.8
■ Connections and Mountings							
Front-connected (FC) Terminal screws	●	●	●	●	●	—	—
With extension bars	○ (BAR)	○ (BAR)	○ (BAR)	○ (BAR)	○ (BAR)	●	●
Rear-connected (RC) Flat bar studs	○	○	○	○	○	○	○
Plug-in (PM) For switchboards	—	—	—	—	—	—	—
For distribution boards	—	—	—	—	—	—	—
Draw-out type (DR)	—	—	—	—	—	—	—
TemPlug70 (PG)	—	—	—	—	—	—	—
TemPlug45B (PG4)	—	—	—	—	—	—	—
DIN rail mount	○ (1)	○ (1)	—	—	—	—	—
Clip-in chassis mount	—	—	—	—	—	—	—
■ Accessories (optional) Symbol							
Interior							
Auxiliary switch	● A X	●	●	●	●	●	●
Alarm switch	● A L	●	●	●	●	●	●
Shunt trips	● S H	●	●	●	●	●	●
Undervoltage trips	● U V	●	●	●	●	●	●
Motor operator	— M C	—	●	●	●	●	●
External operating handle	● H B	●	●	●	●	●	●
Door-mounted (variable depth)	● H P	●	—	●	●	●	●
Toggle extension	— H A	—	—	—	—	●	●
Mechanical interlock	— M S	—	—	—	—	—	—
Slide type	—	—	—	—	—	—	—
Rear-connected type	— M B	—	—	—	—	—	—
Link type	— M L	—	—	—	—	—	—
Wire type	— M W	—	—	—	—	—	—
Exterior							
Toggle holder	● H H	●	●	●	●	●	●
Toggle lock	● H L	●	●	●	●	●	●
Terminal cover For front-connected	● (12) C F	● (12)	● (12)	● (12)	●	●	●
For rear-connected and plug-in	● (12) C R	● (12)	● (12)	● (12)	●	●	●
Interpole barrier	● (13) B A	● (13)	● (13)	● (13)	● (3)	● (3)	● (3)
Terminal block for lead	● T F	●	●	●	●	●	●
Door flange	● D F	●	●	●	●	●	●
■ Standard specifications							
Overcurrent trip mechanism	Adj. thermal, fixed magnetic	Adj. thermal, fixed magnetic	Adj. thermal, fixed magnetic	Adj. thermal, fixed magnetic	Adj. thermal, fixed magnetic	Adj. thermal, fixed magnetic	Fixed thermal, fixed magnetic
Colour of cover	Grey	Grey	Grey	Grey	Grey	Grey	Grey
Trip button (Colour)	Yes (Red)	Yes (Red)	Yes (Red)	Yes (Red)	Yes (Red)	Yes (Red)	Yes (Red)
Handle position indication (ON: Red, OFF: Green)	Yes	Yes	Yes	Yes	Yes	Yes	Yes
Suitability for isolation	Yes	Yes	Yes	Yes	Yes	Yes	Yes
Reverse connection	Yes	Yes	Yes	Yes	Yes	Yes	Yes

Notes:

- : Standard. This configuration used unless otherwise specified. ○ : Optional standard. Specify when ordering. ● : "yes" or "available". — : "no" or "not available".
- ③ : Line side interpole barriers are supplied as standard. (Front connection only)
- ④ : Connect 3pole or 4pole in series when over DC250V.
- ⑤ : The time constant (L/R) of the circuit should be, less than 2.0ms nearby rated current less than 5ms for short circuit ≤ 10KA less than 10ms for short circuit ≤ 20KA less than 15ms for short circuit > 20KA
- ① : Provided with DIN rail adaptor.
- ② : Be sure to install the terminal covers on Line side (ON side) that is supplied as standard.
- ③ : Possible to fit on load side (option).
- ⑦ : + means the dimension of the terminal cover. See outline dimensions for details.

Moulded Case Circuit Breakers for DC350V-600V

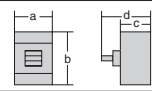
Frame size (A)	1250		1600		2000		2500		3200			
Type	XS1250ND		XS1600ND		XS2000ND		XS2500ND		XS3200ND			
Number of poles	2*	3	2*	3	2*	3	2*	3	2*	3		
■ Ratings												
Rated current, A	1250 ①		1600 ①		2000 ①		2500 ①		3200 ①			
Calibrated at 45°C												
* 2 poles breaker is same outline dimensions as 3 poles breaker.												
Rated insulation voltage [U _i] V	690		690		690		690		690			
Rated impulse withstand voltage [U _{imp}] kV	8		8		8		8		8			
■ Rated breaking capacity, kA												
JIS C 8201-2-1 Ann.1 Ann.2	DC	600V	—	20/15	—	20/15	—	20/15	—	20/15	—	20/15
IEC 60947-2		500V	—	50/25	—	50/25	—	50/25	—	50/25	—	50/25
I _{cu} /I _{cs} ④⑤		350V	—	50/25	—	50/25	—	50/25	—	50/25	—	50/25
		250V	50/30	—	50/30	—	50/30	—	50/30	—	50/30	—
■ External dimensions, mm												
	a	210	210	320	320	320	320	320	320			
	b	370	370	450	450	450	450	450	450			
	c	140	140	185	185	185	185	185	185			
	d	191	191	245	245	245	245	245	245			
Weight (● marked standard type) kg	23.8	26.0	24.0	27.0	50.0	54.0	55.7	62.5	55.7	62.5		
■ Connections and Mountings												
Front-connected (FC)	Terminal screws	—	—	—	—	—	—	—	—	—	—	—
	With extension bars	●	○	○	○	○	○	○	○	○	○	○
Rear-connected (RC)	Flat bar studs	○	●	●	●	●	●	●	●	●	●	●
Plug-in (PM)	For switchboards	—	—	—	—	—	—	—	—	—	—	—
	For distribution boards	—	—	—	—	—	—	—	—	—	—	—
Draw-out type (DR)	—	—	○	○	○	○	○	○	○	○	○	○
TemPlug70 (PG)	—	—	—	—	—	—	—	—	—	—	—	—
TemPlug45B (PG4)	—	—	—	—	—	—	—	—	—	—	—	—
DIN rail mount	—	—	—	—	—	—	—	—	—	—	—	—
Clip-in chassis mount	—	—	—	—	—	—	—	—	—	—	—	—
■ Accessories (optional)	Symbol											
Interior	Auxiliary switch	A X	●	●	●	●	●	●	●	●	●	●
	Alarm switch	A L	●	●	●	●	●	●	●	●	●	●
	Shunt trips	S H	●	●	●	●	●	●	●	●	●	●
	Undervoltage trips	U V	—	—	—	—	—	—	—	—	—	—
	Motor operator	M C	●	●	●	●	●	●	●	●	●	●
	External operating handle	H B	●	●	—	—	—	—	—	—	—	—
	Door-mounted (variable depth)	H P	●	●	● ⑦	● ⑦	● ⑦	● ⑦	● ⑦	● ⑦	● ⑦	● ⑦
	Toggle extension	H A	● ⑥	● ⑥	● ②	● ②	● ②	● ②	● ②	● ②	● ②	● ②
	Mechanical interlock	Slide type	M S	—	—	—	—	—	—	—	—	—
	Rear-connected type	M B	—	—	—	—	—	—	—	—	—	—
	Link type	M L	—	—	—	—	—	—	—	—	—	—
	Wire type	M W	—	—	—	—	—	—	—	—	—	—
Exterior	Toggle holder	H H	●	●	●	●	●	●	●	●	●	●
	Toggle lock	H L	—	—	—	—	—	—	—	—	—	—
	Terminal cover	For front-connected	C F	—	—	—	—	—	—	—	—	—
	For rear-connected and plug-in	C R	—	—	—	—	—	—	—	—	—	—
	Interpole barrier	B A	● ③	● ③	—	—	—	—	—	—	—	—
	Terminal block for lead	T F	●	●	●	●	●	●	●	●	●	●
	Door flange	D F	●	●	●	●	●	●	●	●	●	●
■ Standard specifications												
Overcurrent trip mechanism	Magnetic (adjustable) ①	Magnetic (adjustable) ①	Magnetic (adjustable) ①	Magnetic (adjustable) ①	Magnetic (adjustable) ①	Magnetic (adjustable) ①	Magnetic (adjustable) ①	Magnetic (adjustable) ①	Magnetic (adjustable) ①	Magnetic (adjustable) ①	Magnetic (adjustable) ①	Magnetic (adjustable) ①
Colour of cover	Grey	Grey	Grey	Grey	Grey	Grey	Grey	Grey	Grey	Grey	Grey	Grey
Trip button (Colour)	Yes (Red)	Yes (Red)	Yes (Red)	Yes (Red)	Yes (Red)	Yes (Red)	Yes (Red)	Yes (Red)	Yes (Red)	Yes (Red)	Yes (Red)	Yes (Red)
Handle position indication (ON: Red, OFF: Green)	Yes	Yes	Yes	Yes	Yes	Yes	Yes	Yes	Yes	Yes	Yes	Yes
Suitability for isolation	Yes	Yes	Non	Non	Non	Non	Non	Non	Non	Non	Non	Non
Reverse connection	Non	Non	Non	Non	Non	Non	Non	Non	Non	Non	Non	Non

Notes:

● : Standard. This configuration used unless otherwise specified. ○ : Optional standard. Specify when ordering. ● : "yes" or "available". — : "no" or "not available".

① : Instantaneous trip only.

② : Supplied as standard.

③ : Line side interpole barriers are supplied as standard. (Front connection only)

④ : Connect 3pole in series when over DC250V.

⑤ : The time constant (L/R) of the circuit should be,
 less than 2.0ms nearby rated current
 less than 5ms for short circuit ≤ 10KA
 less than 10ms for short circuit ≤ 20KA
 less than 15ms for short circuit > 20KA

⑥ : One is supplied with every five breakers. Please specify if more are required.

⑦ : Fixed depth. (not adjustable)

Moulded Case Circuit Breakers for DC750V-1000V

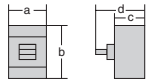
Frame size (A)	160	160	160	160				
Type	PVE160-SDL	PVS160-SDL	PVS160-SDH	PVS160-GDH				
Number of poles	3	3	4	4				
■ Ratings								
Rated current, A	25 (16-25)	50 (32-50)	50 (32-50)	50 (32-50)				
Calibrated at 45°C	32 (20-32)	63 (40-63)	63 (40-63)	63 (40-63)				
	40 (25-40)	100 (63-100)	100 (63-100)	100 (63-100)				
	63 (40-63)	125 (80-125)	125 (80-125)	125 (80-125)				
	80 (50-80)	160 (100-160)	160 (100-160)	160 (100-160)				
	100 (63-100)							
	125 (80-125)							
	160 (100-160)							
Rated insulation voltage [U _i] V	800	800	1000	1000				
Rated impulse withstand voltage [U _{imp}] kV	8	8	8	8				
■ Rated breaking capacity, kA								
JIS C 8201-2-1 Ann.1 Ann.2 DC	1000V	—	5/5	10/5				
IEC 60947-2 I _{cu} /I _{cs} ①②	750V	3/3	10/5	—				
■ External dimensions, mm								
	a	75	105	140	140			
	b	130+50×2 ⑰	165+55×2 ⑰	165+55×2 ⑰	165+55×2 ⑰			
	c	68	68	68	68			
	d	95	95	95	95			
Weight (● marked standard type) kg	0.8	1.5	1.9	1.9				
■ Connections and Mountings								
Front-connected (FC)	Terminal screws	●	●	●	●			
	With extension bars	○ (BAR)	○ (BAR)	○ (BAR)	○ (BAR)			
Rear-connected (RC)	Flat bar studs	○	○	○	○			
Plug-in (PM)	For switchboards	—	—	—	—			
	For distribution boards	—	—	—	—			
Draw-out type (DR)		—	—	—	—			
TemPlug70 (PG)		—	—	—	—			
TemPlug45B (PG4)		—	—	—	—			
DIN rail mount		—	—	—	—			
Clip-in chassis mount		—	—	—	—			
■ Accessories (optional) Symbol								
Interior	Auxiliary switch	A X	●	●	●	●		
	Alarm switch	A L	●	●	●	●		
	Shunt trips	S H	●	●	●	●		
	Undervoltage trips	U V	●	●	●	●		
	Motor operator	M C	—	●	●	●		
	External operating handle	Breaker-mounted	H B	●	●	●		
		Door-mounted (variable depth)	H P	●	●	●		
	Toggle extension	H A	—	—	—	—		
	Mechanical interlock	Slide type	M S	—	—	—	—	
		Rear-connected type	M B	—	—	—	—	
Link type		M L	—	—	—	—		
Wire type		M W	—	—	—	—		
Exterior	Toggle holder	H H	●	●	●	●		
	Toggle lock	H L	●	●	●	●		
	Terminal cover	For front-connected	C F	● ⑧	● ⑧	● ⑧	● ⑧	
		For rear-connected and plug-in	C R	● ⑧	● ⑧	● ⑧	● ⑧	
	Interpole barrier	B A	—	—	—	—		
	Terminal block for lead	T F	●	●	●	●		
	Door flange	D F	●	●	●	●		
■ Standard specifications								
Overcurrent trip mechanism		Adj. thermal, fixed magnetic	Adj. thermal, fixed magnetic	Adj. thermal, fixed magnetic	Adj. thermal, fixed magnetic			
Colour of cover		Grey	Grey	Grey	Grey			
Trip button (Colour)		Yes (Red)	Yes (Red)	Yes (Red)	Yes (Red)			
Handle position indication (ON: Red, OFF: Green)		Yes	Yes	Yes	Yes			
Suitability for isolation		Yes	Yes	Yes	Yes			
Reverse connection		Yes	Yes	Yes	Yes			

Notes:

● : Standard. This configuration used unless otherwise specified. ○ : Optional standard. Specify when ordering. ● : "yes" or "available". — : "no" or "not available".

① : Connect 3poles or 4poles in series.

② : The time constant (L/R) of the circuit should be,
 less than 2.0ms nearby rated current
 less than 5ms for short circuit ≤ 10KA
 less than 10ms for short circuit ≤ 20KA
 less than 15ms for short circuit > 20KA

⑧ : Two terminal covers are supplied as standard. Be sure to install the terminal covers on Line side (ON side) and Load side (OFF side).

⑰ : + means the dimension of the terminal cover. See outline dimensions for details.

Moulded Case Circuit Breakers for DC750V-1000V

Frame size (A)	250	250	250					
Type	PVS250-SDL	PVS250-SDH	PVS250-GDH					
Number of poles	3	4	4					
■ Ratings								
Rated current, A	100 (63-100)	100 (63-100)	100 (63-100)					
Calibrated at 45°C	125 (80-125) 160 (100-160) 200 (125-200) 250 (160-250)	125 (80-125) 160 (100-160) 200 (125-200) 250 (160-250)	125 (80-125) 160 (100-160) 200 (125-200) 250 (160-250)					
■ Rated breaking capacity, kA								
JIS C 8201-2-1 Ann.1 Ann.2	DC	1000V						
IEC 60947-2 I_{cu}/I_{cs} ①②	750V	10/5	5/5	10/5				
■ External dimensions, mm								
	a	105	140	140				
	b	165+55×2 ⑰	165+55×2 ⑰	165+55×2 ⑰				
	c	68	68	68				
	d	95	95	95				
Weight (● marked standard type) kg	1.5	1.9	1.9					
■ Connections and Mountings								
Front-connected (FC)	Terminal screws	●	●	●				
	With extension bars	○ (BAR)	○ (BAR)	○ (BAR)				
Rear-connected (RC)	Flat bar studs	○	○	○				
Plug-in (PM)	For switchboards	—	—	—				
	For distribution boards	—	—	—				
Draw-out type (DR)		—	—	—				
TemPlug70 (PG)		—	—	—				
TemPlug45B (PG4)		—	—	—				
DIN rail mount		—	—	—				
Clip-in chassis mount		—	—	—				
■ Accessories (optional)								
	Symbol							
Interior	Auxiliary switch	A X	●	●	●			
	Alarm switch	A L	●	●	●			
	Shunt trips	S H	●	●	●			
	Undervoltage trips	U V	●	●	●			
	Motor operator	M C	●	●	●			
	External operating handle	Breaker-mounted	H B	●	●	●		
		Door-mounted (variable depth)	H P	●	●	●		
	Toggle extension	H A	—	—	—			
	Mechanical interlock	Slide type	M S	—	—	—		
		Rear-connected type	M B	—	—	—		
Link type		M L	—	—	—			
Wire type		M W	—	—	—			
Exterior	Toggle holder	H H	●	●	●			
	Toggle lock	H L	●	●	●			
	Terminal cover	For front-connected	C F	● ⑧	● ⑧	● ⑧		
		For rear-connected and plug-in	C R	● ⑧	● ⑧	● ⑧		
	Interpole barrier	B A	—	—	—			
	Terminal block for lead	T F	●	●	●			
	Door flange	D F	●	●	●			
■ Standard specifications								
Overcurrent trip mechanism		Adj. thermal, fixed magnetic	Adj. thermal, fixed magnetic	Adj. thermal, fixed magnetic				
Colour of cover		Grey	Grey	Grey				
Trip button (Colour)		Yes (Red)	Yes (Red)	Yes (Red)				
Handle position indication (ON: Red, OFF: Green)		Yes	Yes	Yes				
Suitability for isolation		Yes	Yes	Yes				
Reverse connection		Yes	Yes	Yes				

Notes:

● : Standard. This configuration used unless otherwise specified. ○ : Optional standard. Specify when ordering. ● : "yes" or "available". — : "no" or "not available".

① : Connect 3poles or 4poles in series.

② : The time constant (L/R) of the circuit should be,
less than 2.0ms nearby rated current
less than 5ms for short circuit ≤ 10KA
less than 10ms for short circuit ≤ 20KA
less than 15ms for short circuit > 20KA

⑧ : Two terminal covers are supplied as standard. Be sure to install the terminal covers on Line side (ON side) and Load side (OFF side).

⑰ : + means the dimension of the terminal cover. See outline dimensions for details.

Moulded Case Circuit Breakers for DC750V-1000V

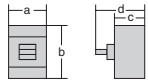
Frame size (A)	400		400		800		800		
Type	PVS400-NDL		PVS400-NDH		PVS800-NDL		PVS800-NDH		
Number of poles	3	4	4		3	4	4		
■ Ratings									
Rated current, A	250 (160-250)	250 (160-250)	250 (160-250)		630 (400-630)	630 (400-630)	630 (400-630)		
Calibrated at 45°C	400 (250-400)	400 (250-400)	400 (250-400)		800 (500-800)	800 (500-800)	800 (500-800)		
Rated insulation voltage [U _i] V	800	1150	1150		800	1150	1150		
Rated impulse withstand voltage [U _{imp}] kV	8	8	8		8	8	8		
■ Rated breaking capacity, kA									
JIS C 8201-2-1 Ann.1 Ann.2 DC	—	—	10/5		—	—	10/5		
IEC 60947-2 I _{cu} /I _{cs} ①②	10/5	10/10	—		10/10	10/10	—		
■ External dimensions, mm									
	a	140	185	185	210	280	280		
	b	260	260	260	273	273	273		
	c	103	103	103	103	103	103		
	d	145	145	145	145	145	145		
Weight (● marked standard type) kg	4.2	5.6	5.6		8.5	11.5	11.5		
■ Connections and Mountings									
Front-connected (FC)	Terminal screws	●	●	●	—	—	—		
	With extension bars	○ (BAR)	○ (BAR)	○ (BAR)	●	●	●		
Rear-connected (RC)	Flat bar studs	○	○	○	○	○	○		
Plug-in (PM)	For switchboards	—	—	—	—	—	—		
	For distribution boards	—	—	—	—	—	—		
Draw-out type (DR)	—	—	—		—	—	—		
TemPlug70 (PG)	—	—	—		—	—	—		
TemPlug45B (PG4)	—	—	—		—	—	—		
DIN rail mount	—	—	—		—	—	—		
Clip-in chassis mount	—	—	—		—	—	—		
■ Accessories (optional)	Symbol								
Interior	Auxiliary switch	A X	●	●	●	●	●	●	
	Alarm switch	A L	●	●	●	●	●	●	
	Shunt trips	S H	●	●	●	●	●	●	
	Undervoltage trips	U V	●	●	●	●	●	●	
	Motor operator	M C	●	●	●	●	●	●	
	External operating handle	Breaker-mounted	H B	●	●	●	●	●	
		Door-mounted (variable depth)	H P	●	●	●	●	●	
	Toggle extension	H A	●	●	●	●	●	●	
	Mechanical interlock	Slide type	M S	—	—	—	—	—	—
		Rear-connected type	M B	—	—	—	—	—	—
Link type		M L	—	—	—	—	—	—	
Wire type		M W	—	—	—	—	—	—	
Exterior	Toggle holder	H H	●	●	●	●	●	●	
	Toggle lock	H L	—	—	—	—	—	—	
	Terminal cover	For front-connected	C F	●	●	●	●	●	
		For rear-connected and plug-in	C R	●	●	●	●	●	
	Interpole barrier	B A	● ⑩	● ⑨	● ⑨	● ⑩	● ⑩	● ⑩	
	Terminal block for lead	T F	●	●	●	●	●	●	
Door flange	D F	—	—	—	—	—	—		
■ Standard specifications									
Overcurrent trip mechanism	Adj. thermal, fixed magnetic	Adj. thermal, fixed magnetic	Adj. thermal, fixed magnetic		Adj. thermal, fixed magnetic	Adj. thermal, fixed magnetic	Adj. thermal, fixed magnetic		
Colour of cover	Grey	Grey	Grey		Grey	Grey	Grey		
Trip button (Colour)	Yes (Red)	Yes (Red)	Yes (Red)		Yes (Red)	Yes (Red)	Yes (Red)		
Handle position indication (ON: Red, OFF: Green)	Yes	Yes	Yes		Yes	Yes	Yes		
Suitability for isolation	Yes	Yes	Yes		Yes	Yes	Yes		
Reverse connection	Yes	Yes	Yes		Yes	Yes	Yes		

Notes:

● : Standard. This configuration used unless otherwise specified. ○ : Optional standard. Specify when ordering. ● : "yes" or "available". — : "no" or "not available".

① : Connect 3poles or 4poles in series.

② : The time constant (L/R) of the circuit should be,
 less than 2.0ms nearby rated current
 less than 5ms for short circuit ≤ 10KA
 less than 10ms for short circuit ≤ 20KA
 less than 15ms for short circuit > 20KA

⑨ : For front connection, both line and load side interpole barriers are supplied as standard.

For rear connection, line side interpole barriers are supplied as standard.

⑩ : For front connection, 5pcs line side interpole barriers and 3pcs load side interpole barriers are supplied as standard.

For rear connection, 5pcs line side interpole barriers are supplied as standard.

⑩ : For front connection and rear connection, 2pcs line side interpole barriers are supplied as standard.

Switch-disconnectors for DC600V-1000V

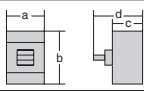
Frame size (A)	160	160	160	250	250	250		
Type	S160-SDN	PVS160-SNL	PVS160-SNH	S250-SDN	PVS250-SNL	PVS250-SNH		
Number of poles	3	4	4	3	3 4	4		
■ Ratings								
Rated current, A	160	160	160	250	250	250		
Rated insulation voltage [U_i] V	690	800	1000	800	800	1000		
Rated operational voltage V	600	800	1000	600	750 800	1000		
Rated short time withstand current, kA	2 (0.3sec.)	3 (0.3sec.)	3 (0.3sec.)	3 (0.3sec.)	3 (0.3sec.)	3 (0.3sec.)		
Rated impulse withstand voltage [U_{imp}] kV	8	8	8	8	8	8		
■ Performance								
Utilization category ①⑱	DC	DC-22A	DC-22A	DC-22A	DC-22A	DC-22A		
JIS C 8201-3 IEC 60947-3								
■ External dimensions, mm								
	a	75	140	140	105	105 140	140	
	b	130+50 ⑰	165+55×2 ⑰	165+55×2 ⑰	165+55 ⑰	165+55×2 ⑰	165+55×2 ⑰	
	c	68	68	68	68	68	68	
	d	95	95	95	95	95	95	
Weight (● marked standard type) kg	0.8	1.9	1.9	1.5	1.5 1.9	1.9		
■ Connections and Mountings								
Front-connected (FC)	Terminal screws With extension bars	● ○ (BAR)	● ○ (BAR)	● ○ (BAR)	● ○ (BAR)	● ○ (BAR)	● ○ (BAR)	
Rear-connected (RC)	Flat bar studs	○	○	○	○	○	○	
Plug-in (PM)	For switchboards For distribution boards	— —	— —	— —	— —	— —	— —	
Draw-out type (DR)	—	—	—	—	—	—	—	
TemPlug70 (PG)	—	—	—	—	—	—	—	
TemPlug45B (PG4)	—	—	—	—	—	—	—	
DIN rail mount	○ ⑪	—	—	—	—	—	—	
Clip-in chassis mount	—	—	—	—	—	—	—	
■ Accessories (optional)	Symbol							
Interior	Auxiliary switch	A X	●	●	●	●	●	
	Alarm switch	A L	●	●	●	●	●	
	Shunt trips	S H	●	●	●	●	●	
	Undervoltage trips	U V	●	●	●	●	●	
	Motor operator	M C	—	●	●	●	●	
	External operating handle	Breaker-mounted Door-mounted (variable depth)	H B H P	● ●	● ●	● ●	● ●	
	Toggle extension	H A	—	—	—	—	—	
	Mechanical interlock	Slide type	M S	—	—	—	—	—
		Rear-connected type	M B	—	—	—	—	—
		Link type	M L	—	—	—	—	—
Wire type		M W	—	—	—	—	—	
Exterior	Toggle holder	H H	●	●	●	●	●	
	Toggle lock	H L	●	●	●	●	●	
	Terminal cover	For front-connected	C F	● ⑫	●	● ⑧	● ⑧	● ⑧
		For rear-connected and plug-in	C R	● ⑫	●	● ⑧	● ⑧	● ⑧
	Interpole barrier	B A	● ⑬	●	—	● ⑬	—	
	Terminal block for lead	T F	●	●	●	●	●	
	Door flange	D F	●	●	●	●	●	
■ Standard specifications								
Colour of cover	Grey	Grey	Grey	Grey	Grey	Grey		
Trip button (Colour)	Yes (Red)	Yes (Red)	Yes (Red)	Yes (Red)	Yes (Red)	Yes (Red)		
Handle position indication (ON: Red, OFF: Green)	Yes	Yes	Yes	Yes	Yes	Yes		
Suitability for isolation	Yes	Yes	Yes	Yes	Yes	Yes		
Reverse connection	Yes	Yes	Yes	Yes	Yes	Yes		

Notes:

- : Standard. This configuration used unless otherwise specified. ○ : Optional standard. Specify when ordering. ● : "yes" or "available". — : "no" or "not available".
- ① : Connect 3poles or 4poles in series.
- ⑧ : Two terminal covers are supplied as standard. Be sure to install the terminal covers on Line side (ON side) and Load side (OFF side).
- ⑪ : Provided with DIN rail adaptor.
- ⑫ : Be sure to install the terminal covers on Line side (ON side) that is supplied as standard.
- ⑬ : Possible to fit on load side (option).
- ⑰ : + means the dimension of the terminal cover. See outline dimensions for details.
- ⑱ : The time constant (L/R) of the circuit should be less than 2.0ms nearby rated current.

Switch-disconnectors for DC600V-1000V

Frame size (A)	400		400		800		800					
Type	PVS400-NNL		PVS400-NNH		PVS800-NNL		PVS800-NNH					
Number of poles	3	4	4		3	4	4					
■ Ratings												
Rated current, A	400		400		630 800		630 800					
■ Performance												
Rated insulation voltage [U_i] V	800	1150	1150		800	1150	1150					
Rated operational voltage V	750	800	1000		750	800	1000					
Rated short time withstand current, kA	5 (0.3sec.)		5 (0.3sec.)		10 (0.3sec.)		10 (0.3sec.)					
Rated impulse withstand voltage [U_{imp}] kV	8		8		8		8					
Utilization category ①⑱	DC		DC-22A		DC-22A		DC-22A					
JIS C 8201-3 IEC 60947-3												
■ External dimensions, mm												
	a	140	185	185	210	280	280					
	b	260		260	273		273					
	c	103		103	103		103					
	d	145		145	145		145					
Weight (● marked standard type) kg	4.2	5.6		5.6	8.5	11.5	11.5					
■ Connections and Mountings												
Front-connected (FC)	Terminal screws	●		●	●		●					
	With extension bars	○ (BAR)		○ (BAR)	●		●					
Rear-connected (RC)	Flat bar studs	○		○	○		○					
Plug-in (PM)	For switchboards	—		—	—		—					
	For distribution boards	—		—	—		—					
Draw-out type (DR)		—		—	—		—					
TemPlug70 (PG)		—		—	—		—					
TemPlug45B (PG4)		—		—	—		—					
DIN rail mount		—		—	—		—					
Clip-in chassis mount		—		—	—		—					
■ Accessories (optional)												
		Symbol										
Interior	Auxiliary switch	A X		●	●	●	●					
	Alarm switch	A L		●	●	●	●					
	Shunt trips	S H		●	●	●	●					
	Undervoltage trips	U V		●	●	●	●					
	Motor operator	M C		●	●	●	●					
	External operating handle	Breaker-mounted		H B	●	●	●	●				
		Door-mounted (variable depth)		H P	●	●	●	●				
	Toggle extension	H A		—	—	●	●					
	Exterior	Mechanical interlock	Slide type	M S	—	—	—	—				
			Rear-connected type	M B	—	—	—	—				
Toggle holder		Link type	M L	—	—	—	—					
		Wire type	M W	—	—	—	—					
		Toggle lock	H H	●	●	●	●					
Terminal cover		For front-connected	C F	●	●	●	●					
		For rear-connected and plug-in	C R	●	●	●	●					
Interpole barrier	B A		● ⑨	● ⑨	● ⑳	● ⑩	● ⑩					
Terminal block for lead	T F		●	●	●	●						
Door flange	D F		—	—	—	—						
■ Standard specifications												
Colour of cover	Grey		Grey		Grey		Grey					
Trip button (Colour)	Yes (Red)		Yes (Red)		Yes (Red)		Yes (Red)					
Handle position indication (ON: Red, OFF: Green)	Yes		Yes		Yes		Yes					
Suitability for isolation	Yes		Yes		Yes		Yes					
Reverse connection	Yes		Yes		Yes		Yes					

Notes:

- : Standard. This configuration used unless otherwise specified. ○ : Optional standard. Specify when ordering. ● : "yes" or "available". — : "no" or "not available".
- ① : Connect 4poles in series.
- ⑨ : For front connection, both line and load side interpole barriers are supplied as standard. For rear connection, line side interpole barriers are supplied as standard.
- ⑩ : For front connection, 5pcs line side interpole barriers and 3pcs load side interpole barriers are supplied as standard. For rear connection, 5pcs line side interpole barriers are supplied as standard.
- ⑱ : The time constant (L/R) of the circuit should be less than 2.0ms nearby rated current.
- ⑳ : For front connection, 4pcs line side interpole barriers and 2pcs load side interpole barriers are supplied as standard. For rear connection, 4pcs line side interpole barriers are supplied as standard.

3

Characteristics

Time/Current characteristic curves, Ambient Compensating Curves

S160-SD, S160-GD, PVE160-SDL, S250-SD, S250-GD 3P	3-2
S400-ND, S800-ND 3P	3-3
S1000-ND 2P, 3P	3-3
XS1250ND, XS1600ND, XS2000ND 2P, 3P	3-4
XS2500ND, XS3200ND 2P, 3P	3-5
PVS160-SDL, PVS250-SDL 3P	3-6
PVS160-SDH, PVS250-SDH 4P	3-6
PVS160-GDH, PVS250-GDH 4P	3-6
PVS400-NDL 3P	3-6
PVS400-NDL, PVS400-NDH, PVS800-NDH 4P	3-7
PVS800-NDL 3P, 4P	3-7

Time/Current characteristic curves, Ambient Compensating Curves

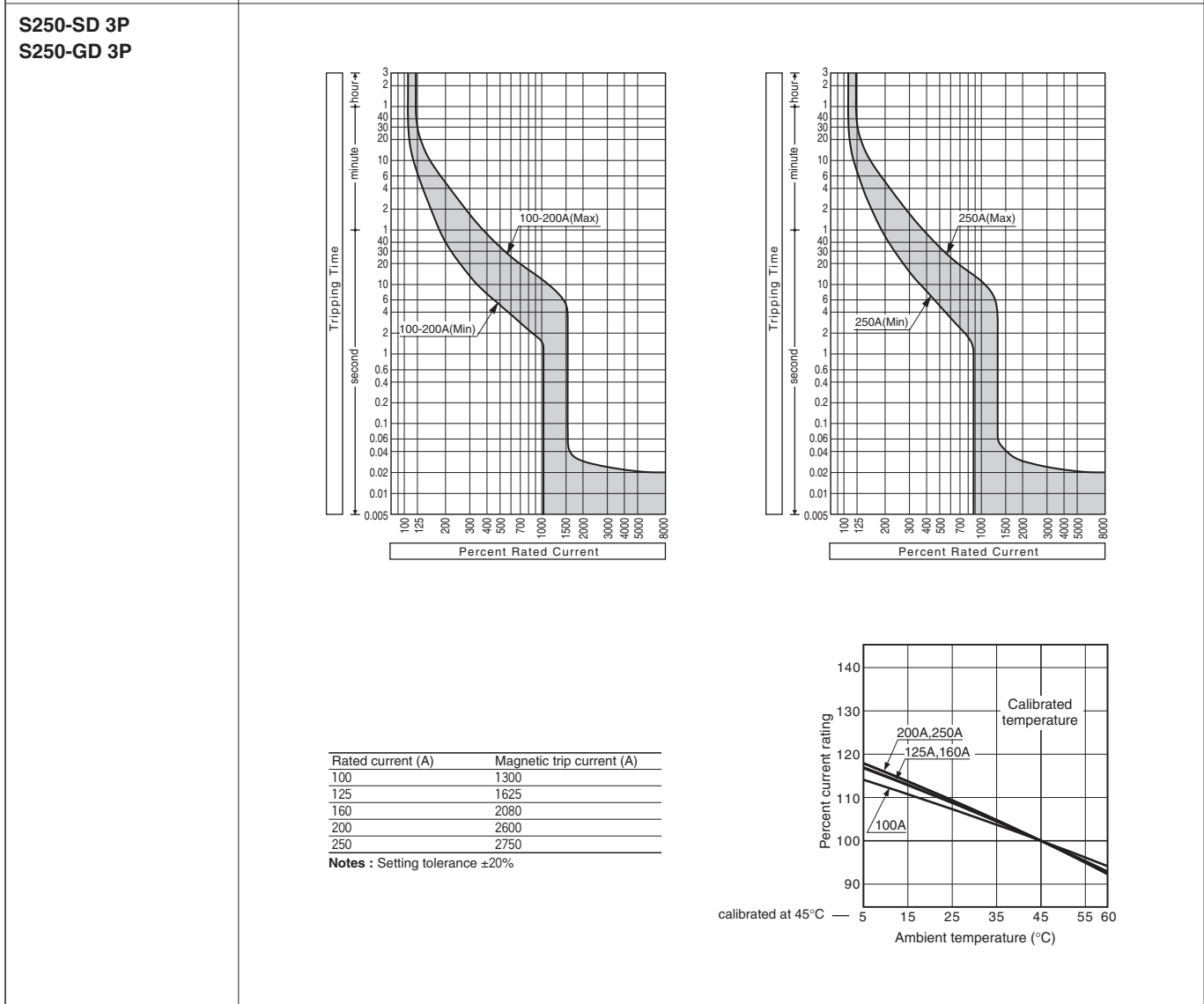
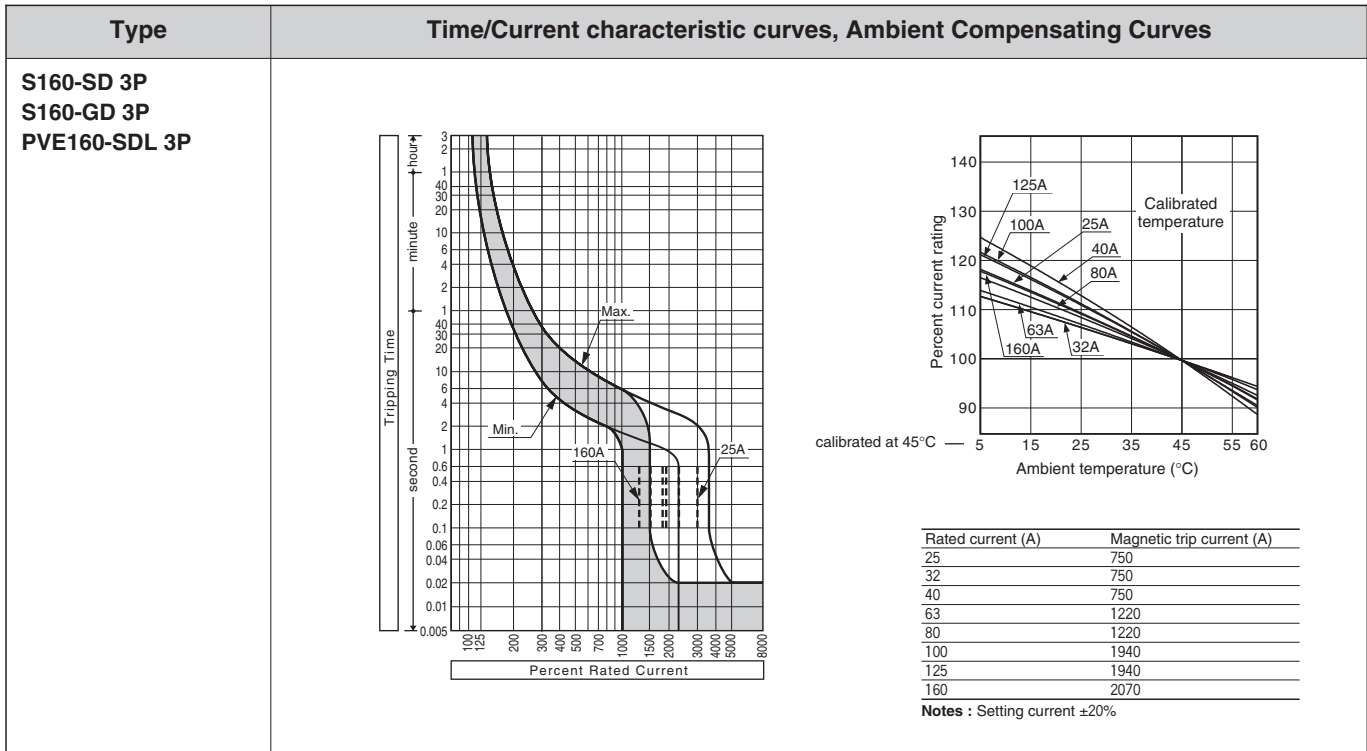

Time/Current characteristic curves, Ambient Compensating Curves

Type	Time/Current characteristic curves, Ambient Compensating Curves							
S400-ND 3P		<table border="1" data-bbox="1061 772 1444 840"> <thead> <tr> <th>Rated current (A)</th> <th>Magnetic trip current (A)</th> </tr> </thead> <tbody> <tr> <td>250</td> <td>3000</td> </tr> <tr> <td>400</td> <td>4800</td> </tr> </tbody> </table> <p data-bbox="1061 840 1276 862">Notes : Setting tolerance $\pm 20\%$</p>	Rated current (A)	Magnetic trip current (A)	250	3000	400	4800
Rated current (A)	Magnetic trip current (A)							
250	3000							
400	4800							
S800-ND 3P		<table border="1" data-bbox="1061 1411 1444 1467"> <thead> <tr> <th>Rated current (A)</th> <th>Magnetic trip current (A)</th> </tr> </thead> <tbody> <tr> <td>630</td> <td>6300</td> </tr> <tr> <td>800</td> <td>8000</td> </tr> </tbody> </table> <p data-bbox="1061 1467 1276 1489">Notes : Setting tolerance $\pm 20\%$</p>	Rated current (A)	Magnetic trip current (A)	630	6300	800	8000
Rated current (A)	Magnetic trip current (A)							
630	6300							
800	8000							
S1000-ND 2P, 3P		<table border="1" data-bbox="1061 2038 1444 2083"> <thead> <tr> <th>Rated current (A)</th> <th>Magnetic trip current (A)</th> </tr> </thead> <tbody> <tr> <td>1000</td> <td>8000</td> </tr> </tbody> </table> <p data-bbox="1061 2083 1276 2105">Notes : Setting tolerance $\pm 20\%$</p>	Rated current (A)	Magnetic trip current (A)	1000	8000		
Rated current (A)	Magnetic trip current (A)							
1000	8000							

Time/Current characteristic curves, Ambient Compensating Curves

Type	Time/Current characteristic curves, Ambient Compensating Curves													
XS1250ND 2P, 3P		<table border="1" data-bbox="831 734 1410 792"> <thead> <tr> <th>Rated current (A) Scale</th> <th colspan="5">Magnetic trip current (A)</th> </tr> </thead> <tbody> <tr> <td>1250</td> <td>8000</td> <td>7100</td> <td>6300</td> <td>5000</td> <td>4000</td> </tr> </tbody> </table> <p data-bbox="831 797 1299 819">Notes : Setting tolerance $\pm 10\%$ at 8000A and $\pm 25\%$ for other settings.</p> <p data-bbox="831 871 1299 893">Note: Magnetic trip only. Use the external over-current relay.</p>	Rated current (A) Scale	Magnetic trip current (A)					1250	8000	7100	6300	5000	4000
Rated current (A) Scale	Magnetic trip current (A)													
1250	8000	7100	6300	5000	4000									
XS1600ND 2P, 3P		<table border="1" data-bbox="831 1346 1410 1404"> <thead> <tr> <th>Rated current (A) Scale</th> <th colspan="5">Magnetic trip current (A)</th> </tr> </thead> <tbody> <tr> <td>1600</td> <td>8000</td> <td>7100</td> <td>6300</td> <td>5000</td> <td>4000</td> </tr> </tbody> </table> <p data-bbox="831 1408 1299 1431">Notes : Setting tolerance $\pm 10\%$ at 8000A and $\pm 25\%$ for other settings.</p> <p data-bbox="831 1482 1299 1505">Note: Magnetic trip only. Use the external over-current relay.</p>	Rated current (A) Scale	Magnetic trip current (A)					1600	8000	7100	6300	5000	4000
Rated current (A) Scale	Magnetic trip current (A)													
1600	8000	7100	6300	5000	4000									
XS2000ND 2P, 3P		<table border="1" data-bbox="831 1957 1410 2016"> <thead> <tr> <th>Rated current (A) Scale</th> <th colspan="5">Magnetic trip current (A)</th> </tr> </thead> <tbody> <tr> <td>2000</td> <td>8000</td> <td>7100</td> <td>6300</td> <td>5000</td> <td>4000</td> </tr> </tbody> </table> <p data-bbox="831 2020 1299 2042">Notes : Setting tolerance $\pm 10\%$ at 8000A and $\pm 25\%$ for other settings.</p> <p data-bbox="831 2094 1299 2116">Note: Magnetic trip only. Use the external over-current relay.</p>	Rated current (A) Scale	Magnetic trip current (A)					2000	8000	7100	6300	5000	4000
Rated current (A) Scale	Magnetic trip current (A)													
2000	8000	7100	6300	5000	4000									

Time/Current characteristic curves, Ambient Compensating Curves

Type	Time/Current characteristic curves, Ambient Compensating Curves																			
<p>XS2500ND 2P, 3P</p>		<table border="1" data-bbox="874 734 1458 792"> <thead> <tr> <th>Rated current (A) Scale</th> <th colspan="5">Magnetic trip current (A)</th> </tr> </thead> <tbody> <tr> <td>2500</td> <td>8</td> <td>7.1</td> <td>6.3</td> <td>5</td> <td>4</td> </tr> <tr> <td></td> <td>8000</td> <td>7100</td> <td>6300</td> <td>5000</td> <td>4000</td> </tr> </tbody> </table> <p>Notes : Setting tolerance $\pm 10\%$ at 8000A and $\pm 25\%$ for other settings.</p> <p>Note: Magnetic trip only. Use the external over-current relay.</p>	Rated current (A) Scale	Magnetic trip current (A)					2500	8	7.1	6.3	5	4		8000	7100	6300	5000	4000
Rated current (A) Scale	Magnetic trip current (A)																			
2500	8	7.1	6.3	5	4															
	8000	7100	6300	5000	4000															
<p>XS3200ND 2P, 3P</p>		<table border="1" data-bbox="874 1348 1458 1406"> <thead> <tr> <th>Rated current (A) Scale</th> <th colspan="5">Magnetic trip current (A)</th> </tr> </thead> <tbody> <tr> <td>3200</td> <td>12</td> <td>11</td> <td>10</td> <td>8</td> <td>6</td> </tr> <tr> <td></td> <td>12000</td> <td>11000</td> <td>10000</td> <td>8000</td> <td>6000</td> </tr> </tbody> </table> <p>Notes : Setting tolerance $\pm 10\%$ at 12000A and $\pm 25\%$ for other settings.</p> <p>Note: Magnetic trip only. Use the external over-current relay.</p>	Rated current (A) Scale	Magnetic trip current (A)					3200	12	11	10	8	6		12000	11000	10000	8000	6000
Rated current (A) Scale	Magnetic trip current (A)																			
3200	12	11	10	8	6															
	12000	11000	10000	8000	6000															

Time/Current characteristic curves, Ambient Compensating Curves

Type Time/Current characteristic curves, Ambient Compensating Curves

PVS160-SDL 3P
 PVS160-SDH 4P
 PVS160-GDH 4P
 PVS250-SDL 3P
 PVS250-SDH 4P
 PVS250-GDH 4P

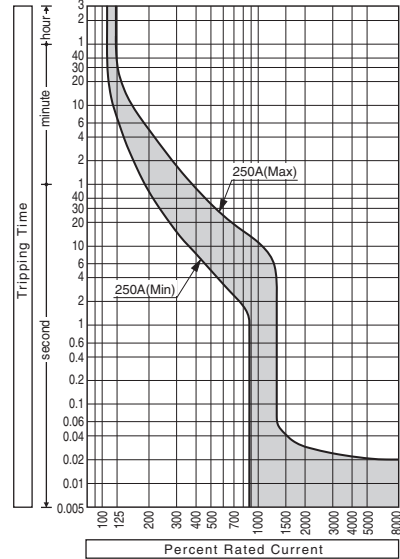
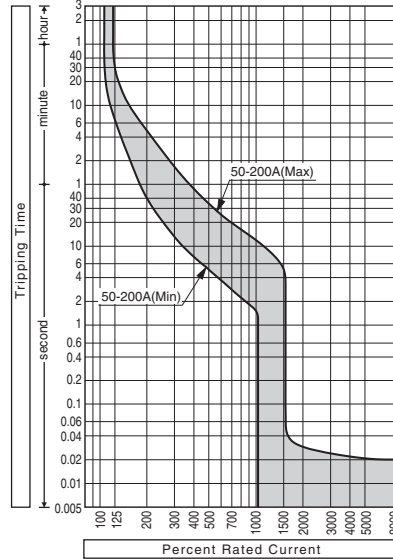

PVS160-SDL, PVS160-SDH, PVS160-GDH

Rated current (A)	Magnetic trip current (A)
50	650
63	819
100	1300
125	1625
160	2080

Notes : Setting tolerance $\pm 20\%$

PVS250-SDL, PVS250-SDH, PVS250-GDH

Rated current (A)	Magnetic trip current (A)
100	1300
125	1625
160	2080
200	2600
250	2750

Notes : Setting tolerance $\pm 20\%$

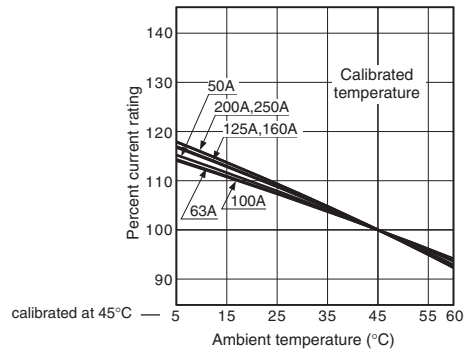

PVS400-NDL 3P

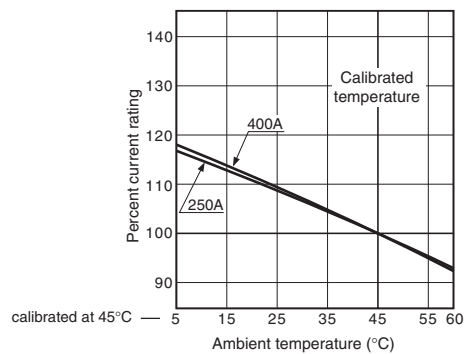
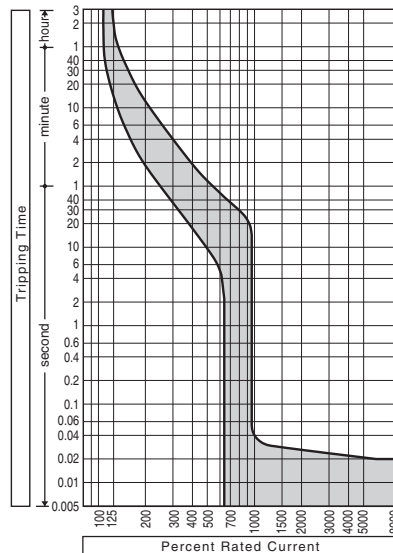

Rated current (A)	Magnetic trip current (A)
250	2000
400	3200

Notes : Setting tolerance $\pm 20\%$

Time/Current characteristic curves, Ambient Compensating Curves

Type	Time/Current characteristic curves, Ambient Compensating Curves							
PVS400-NDL 4P		<table border="1" data-bbox="1050 801 1433 862"> <thead> <tr> <th>Rated current (A)</th> <th>Magnetic trip current (A)</th> </tr> </thead> <tbody> <tr> <td>250</td> <td>3000</td> </tr> <tr> <td>400</td> <td>4800</td> </tr> </tbody> </table> <p data-bbox="1050 862 1268 884">Notes : Setting tolerance $\pm 20\%$</p>	Rated current (A)	Magnetic trip current (A)	250	3000	400	4800
Rated current (A)	Magnetic trip current (A)							
250	3000							
400	4800							
PVS400-NDH 4P		<table border="1" data-bbox="1050 1415 1433 1476"> <thead> <tr> <th>Rated current (A)</th> <th>Magnetic trip current (A)</th> </tr> </thead> <tbody> <tr> <td>250</td> <td>2000</td> </tr> <tr> <td>400</td> <td>3200</td> </tr> </tbody> </table> <p data-bbox="1050 1476 1268 1498">Notes : Setting tolerance $\pm 20\%$</p>	Rated current (A)	Magnetic trip current (A)	250	2000	400	3200
Rated current (A)	Magnetic trip current (A)							
250	2000							
400	3200							
PVS800-NDL 3P, 4P PVS800-NDH 4P		<table border="1" data-bbox="1050 2020 1433 2080"> <thead> <tr> <th>Rated current (A)</th> <th>Magnetic trip current (A)</th> </tr> </thead> <tbody> <tr> <td>630</td> <td>3500</td> </tr> <tr> <td>800</td> <td>3500</td> </tr> </tbody> </table> <p data-bbox="1050 2080 1268 2103">Notes : Setting tolerance $\pm 20\%$</p>	Rated current (A)	Magnetic trip current (A)	630	3500	800	3500
Rated current (A)	Magnetic trip current (A)							
630	3500							
800	3500							

4 Mounting and Connection

Connection of conductors to DC circuit breakers	4-2
Insulation distance DC600V or less	4-7
Insulation distance DC750V-1000V	
PVE160-SDL 3P	4-8
PVS160-SDL 3P, PVS250-SDL 3P, PVS250-SNL 3P	4-9
PVS160-SNL 4P, PVS250-SNL 4P	4-10
PVS160-GDH 4P, PVS250-GDH 4P	4-11
PVS160-SDH 4P, PVS250-SDH 4P	4-12
PVS160-SNH 4P, PVS250-SNH 4P	4-13
PVS400-NDL 3P	4-14
PVS400-NDL 4P, PVS400-NDH 4P	4-15
PVS400-NNL 3P	4-16
PVS400-NNL 4P, PVS400-NNH 4P	4-17
PVS800-NDL 3P	4-18
PVS800-NDL 4P, PVS800-NDH 4P	4-19
PVS800-NNL 3P	4-20
PVS800-NNL 4P, PVS800-NNH 4P	4-21

Connection of conductors to DC circuit breakers

It is more difficult to interrupt DC current than AC current because DC current does not have a zero point. Therefore for high DC voltages, 3-pole or 4-pole circuit breaker main contacts are connected in series to ensure breaking performance. As illustrated below, the main power conductors for DC-use air circuit breakers, moulded case circuit breakers, and switch disconnectors shall be connected generally as shown below but also depending on the type of breaker, the number of poles, and the DC operating voltage.

		Non-grounded system (Protection + Isolation function)		Grounded system (Protection)		Grounded system (Protection + Isolation function)	
		Ordinally connection					
		Reverse connection					
Type of breakers	No.s of poles	Applicable voltage (V)	Rated breaking capacity I_{cu}/I_{cs}	Applicable voltage (V)	Rated breaking capacity I_{cu}/I_{cs}	Applicable voltage (V)	Rated breaking capacity I_{cu}/I_{cs}
S1000-ND	2P	≤ 250	50kA/20kA	≤ 250	50kA/20kA	≤ 150	50kA/20kA

* : 2 poles breaker is a 3 pole breaker with the center pole omitted.

		Non-grounded system (Protection + Isolation function)		Grounded system (Protection)		Grounded system (Protection + Isolation function)	
		Ordinally connection					
		Reverse connection					
Type of breakers	No.s of poles	Applicable voltage (V)	Rated breaking capacity I_{cu}/I_{cs}	Applicable voltage (V)	Rated breaking capacity I_{cu}/I_{cs}	Applicable voltage (V)	Rated breaking capacity I_{cu}/I_{cs}
XS1250ND	2P	≤ 250	50kA/30kA	≤ 250	50kA/30kA	≤ 150	50kA/30kA
XS1600ND	2P	≤ 250	50kA/30kA	≤ 250	50kA/30kA	≤ 150	50kA/30kA
XS2000ND	2P	≤ 250	50kA/30kA	≤ 250	50kA/30kA	≤ 150	50kA/30kA
XS2500ND	2P	≤ 250	50kA/30kA	≤ 250	50kA/30kA	≤ 150	50kA/30kA
XS3200ND	2P	≤ 250	50kA/30kA	≤ 250	50kA/30kA	≤ 150	50kA/30kA

* : 2 poles breaker is a 3 pole breaker with the center pole omitted.

Type of breakers	No.s of poles	Non-grounded system (Protection + Isolation function)		Grounded system (Protection)		Grounded system (Protection + Isolation function)	
		Applicable voltage (V)	Rated breaking capacity I_{cu}/I_{cs}	Applicable voltage (V)	Rated breaking capacity I_{cu}/I_{cs}	Applicable voltage (V)	Rated breaking capacity I_{cu}/I_{cs}
		Ordinally connection		Reverse connection			
		Reverse connection		Ordinally connection			
S160-SD	3P	≤ 600	5kA/5kA	≤ 600	5kA/5kA	≤ 400	5kA/5kA
S160-SD	3P	≤ 500	7.5kA/7.5kA	≤ 500	7.5kA/7.5kA	≤ 350	7.5kA/7.5kA
S160-SD	3P	≤ 350	10kA/10kA	≤ 350	10kA/10kA	≤ 250	10kA/10kA
S160-GD	3P	≤ 600	10kA/5kA	≤ 600	10kA/5kA	≤ 400	10kA/5kA
S160-GD	3P	≤ 500	15kA/7.5kA	≤ 500	15kA/7.5kA	≤ 350	15kA/7.5kA
S250-SD	3P	≤ 600	5kA/5kA	≤ 600	5kA/5kA	≤ 400	5kA/5kA
S250-SD	3P	≤ 500	7.5kA/7.5kA	≤ 500	7.5kA/7.5kA	≤ 350	7.5kA/7.5kA
S250-SD	3P	≤ 350	10kA/10kA	≤ 350	10kA/10kA	≤ 250	10kA/10kA
S250-GD	3P	≤ 600	10kA/5kA	≤ 600	10kA/5kA	≤ 400	10kA/5kA
S250-GD	3P	≤ 500	15kA/7.5kA	≤ 500	15kA/7.5kA	≤ 350	15kA/7.5kA
S400-ND	3P	≤ 600	15kA/15kA	≤ 600	15kA/15kA	≤ 400	15kA/15kA
S400-ND	3P	≤ 350	20kA/20kA	≤ 350	20kA/20kA	≤ 250	20kA/20kA
S800-ND	3P	≤ 600	20kA/10kA	≤ 600	20kA/10kA	≤ 400	20kA/10kA
S800-ND	3P	≤ 350	30kA/15kA	≤ 350	30kA/15kA	≤ 250	30kA/15kA
S1000-ND	3P	≤ 600	20kA/10kA	≤ 600	20kA/10kA	≤ 400	20kA/10kA
S1000-ND	3P	≤ 350	30kA/15kA	≤ 350	30kA/15kA	≤ 250	30kA/15kA
PVE160-SDL	3P	≤ 750	3kA/3kA	≤ 750	3kA/3kA	≤ 500	3kA/3kA
PVS160-SDL	3P	≤ 750	10kA/5kA	≤ 750	10kA/5kA	≤ 500	10kA/5kA
PVS250-SDL	3P	≤ 750	10kA/5kA	≤ 750	10kA/5kA	≤ 500	10kA/5kA
PVS400-NDL	3P	≤ 750	10kA/5kA	≤ 750	10kA/5kA	≤ 500	10kA/5kA
PVS800-NDL	3P	≤ 750	10kA/10kA	≤ 750	10kA/10kA	≤ 500	10kA/10kA
S160-SDN	3P	≤ 600	—	≤ 600	—	≤ 400	—
S250-SDN	3P	≤ 600	—	≤ 600	—	≤ 400	—
PVS250-SNL	3P	≤ 750	—	≤ 750	—		
PVS400-NNL	3P	≤ 750	—	≤ 750	—		
PVS800-NNL	3P	≤ 750	—	≤ 750	—		

Connection of conductors to DC circuit breakers

		Non-grounded system (Protection + Isolation function)		Grounded system (Protection)		Grounded system (Protection + Isolation function)	
Ordinally connection							
Type of breakers	No.s of poles	Applicable voltage (V)	Rated breaking capacity I_{cu}/I_{cs}	Applicable voltage (V)	Rated breaking capacity I_{cu}/I_{cs}	Applicable voltage (V)	Rated breaking capacity I_{cu}/I_{cs}
XS1250ND	3P	≤ 600	20kA/15kA	≤ 600	20kA/15kA	≤ 400	20kA/15kA
XS1250ND	3P	≤ 500	50kA/25kA	≤ 500	50kA/25kA	≤ 350	50kA/25kA
XS1600ND	3P	≤ 600	20kA/15kA	≤ 600	20kA/15kA	≤ 400	20kA/15kA
XS1600ND	3P	≤ 500	50kA/25kA	≤ 500	50kA/25kA	≤ 350	50kA/25kA
XS2000ND	3P	≤ 600	20kA/15kA	≤ 600	20kA/15kA	≤ 400	20kA/15kA
XS2000ND	3P	≤ 500	50kA/25kA	≤ 500	50kA/25kA	≤ 350	50kA/25kA
XS2500ND	3P	≤ 600	20kA/15kA	≤ 600	20kA/15kA	≤ 400	20kA/15kA
XS2500ND	3P	≤ 500	50kA/25kA	≤ 500	50kA/25kA	≤ 350	50kA/25kA
XS3200ND	3P	≤ 600	20kA/15kA	≤ 600	20kA/15kA	≤ 400	20kA/15kA
XS3200ND	3P	≤ 500	50kA/25kA	≤ 500	50kA/25kA	≤ 350	50kA/25kA

Connection of conductors to DC circuit breakers

		Non-grounded system (Protection + Isolation function)		Grounded system (Protection)		Grounded system (Protection + Isolation function)	
Ordinally connection							
Reverse connection							
Type of breakers	No.s of poles	Applicable voltage (V)	Rated breaking capacity I_{cu}/I_{cs}	Applicable voltage (V)	Rated breaking capacity I_{cu}/I_{cs}	Applicable voltage (V)	Rated breaking capacity I_{cu}/I_{cs}
AR208S ③	3P	≤ 600	40kA/40kA	≤ 600	40kA/40kA	≤ 400	40kA/40kA
AR212S ③	3P	≤ 600	40kA/40kA	≤ 600	40kA/40kA	≤ 400	40kA/40kA
AR216S ③	3P	≤ 600	40kA/40kA	≤ 600	40kA/40kA	≤ 400	40kA/40kA
AR220S ③	3P	≤ 600	40kA/40kA	≤ 600	40kA/40kA	≤ 400	40kA/40kA
AR325S ③	3P	≤ 600	40kA/40kA	≤ 600	40kA/40kA	≤ 400	40kA/40kA
AR332S ③	3P	≤ 600	40kA/40kA	≤ 600	40kA/40kA	≤ 400	40kA/40kA
AR440S ③	3P	≤ 600	40kA/40kA	≤ 600	40kA/40kA	≤ 400	40kA/40kA

Note ③ : AGR over-current release can not be used for DC. Please prepare DC over-current relay and connect with shunt trip device.

		Non-grounded system (Protection + Isolation function)		Grounded system (Protection)		Grounded system (Protection + Isolation function)	
Ordinally connection							
Reverse connection							
Type of breakers	No.s of poles	Applicable voltage (V)	Rated breaking capacity I_{cu}/I_{cs}	Applicable voltage (V)	Rated breaking capacity I_{cu}/I_{cs}	Applicable voltage (V)	Rated breaking capacity I_{cu}/I_{cs}
AR325-NDH ③	4P	≤ 800	30kA/30kA	≤ 800	30kA/30kA	≤ 600	30kA/30kA

Note ③ : AGR over-current release can not be used for DC. Please prepare DC over-current relay and connect with shunt trip device.

Insulation distance DC600V or less

The insulation distances between the breaker and earthed metal parts and insulators shown in the table below must be maintained to prevent arcing faults occurring due to conductive ionised gas. In addition, any exposed line-side conductors must be completely covered, right up the breaker casing or to below the height protected by any interpole barriers. This can be done by using an insulation tube or tape, in order to provide positive protection against short circuit or ground fault due to metal chipping, surge voltage, dust particles or salt. If terminal covers are not being used, the interpole barriers supplied with the breaker as standard must be used.

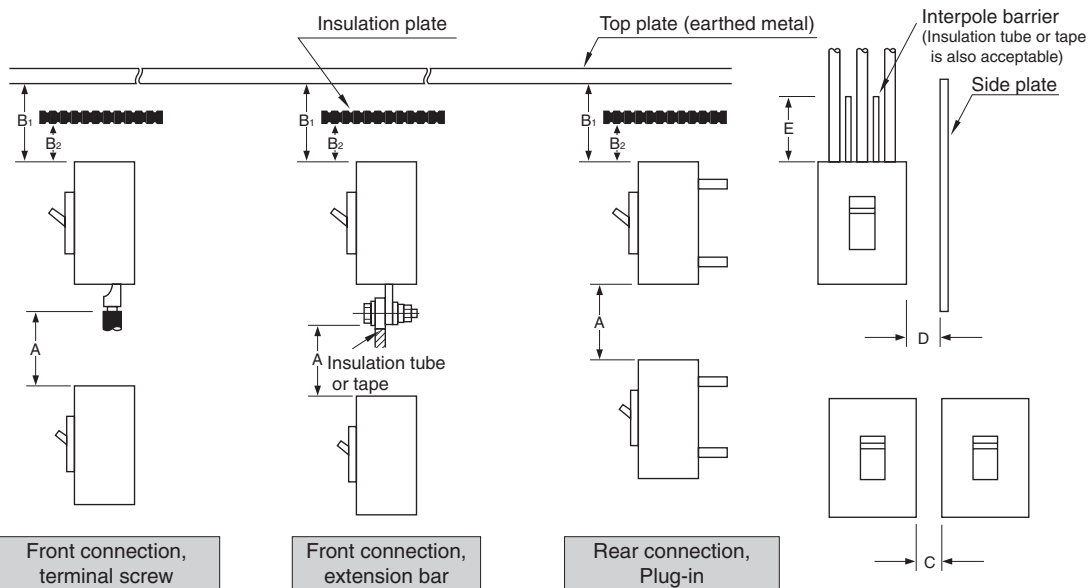
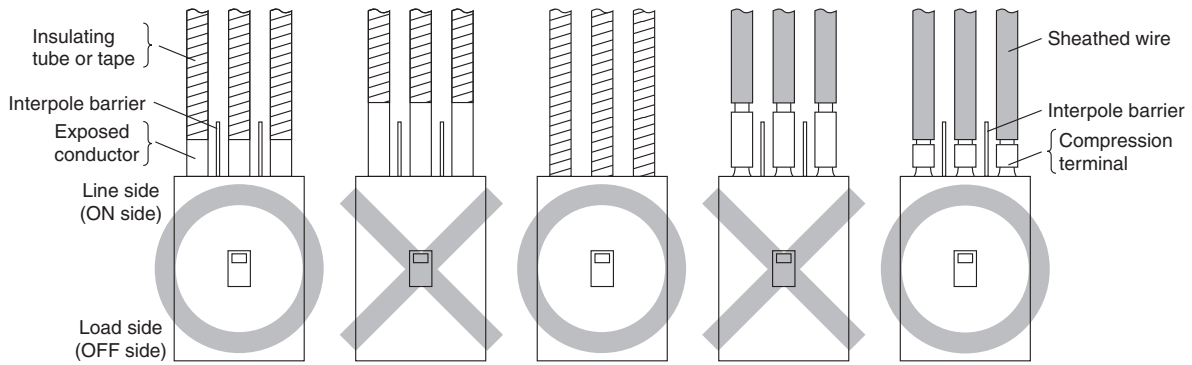

- A . Distance from lower breaker to exposed live part of upper breaker terminal (front connection) or distance from lower breaker to end face of upper breaker (rear connection).
- B1. Distance from end face of breaker to top plate.
- B2. Distance from end face of breaker to insulation plate.
- C . Gap between breakers.
- D . Distance from side of breaker to side plate (earthed metal).
- E . Dimension of insulation over exposed conductors.

Insulation distance, mm (DC 600 V or less) ^{Note ①}

Moulded Case Circuit Breakers				A Note ②	B1	B2	C	D	E
S160-SD	S160-GD	S160-SDN	⑤	50	50	50	* Possible to set close Note ③	25	Not less than the length of the bare live part Note ④
S250-SD	S250-GD	S250-SDN	⑤	65	65	65	*	50	∕
S400-ND	S800-ND	S1000-ND		150	120	80	∕	80	∕
XS1250ND	XS1600ND	XS2000ND	XS2500ND	XS3200ND	150	150	100	100	∕

Notes:

- ①. Required to allow free and uninterrupted flow of arc gases. Ensure additional clearance or insulation distance if required to perform wiring, barrier installation or electrical work or to meet the need for more insulation distance between bare live parts and grounded metal members in a switchboard or the like.
- ②. The figures are for lower breakers.
- ③. When the accessories are fitted it is not possible to set close.
- ④. For front connected breakers, insulate all exposed conductors of the line side until the breaker end. If interpole barriers are packed, be sure to use the barriers; more over, insulate all exposed conductors by insulating tape or the like so that the tape overlaps with the barriers.
- ⑤. Be sure to install the terminal covers (supplied as standard) on the line side of the breakers.
- *. If using extension bars (optional), ensure the insulation distance specified for the application.

Insulation distance DC750V-1000V

The insulation distances between the breaker and earthed metal parts and insulators shown in the table below must be maintained to prevent arcing faults occurring due to conductive ionised gas. In addition, any exposed line-side conductors must be completely covered, right up the breaker casing or to below the height protected by any terminal covers or interpole barriers. This can be done by using an insulation tube or tape, in order to provide positive protection against short circuit or ground fault due to metal chipping, surge voltage, dust particles or salt. The terminal covers or the interpole barriers supplied with the breaker as standard must be used. For DC750V-1000V breakers, the front and the rear insulating plates must also be installed.

PVE160-SDL 3P

Front-connected

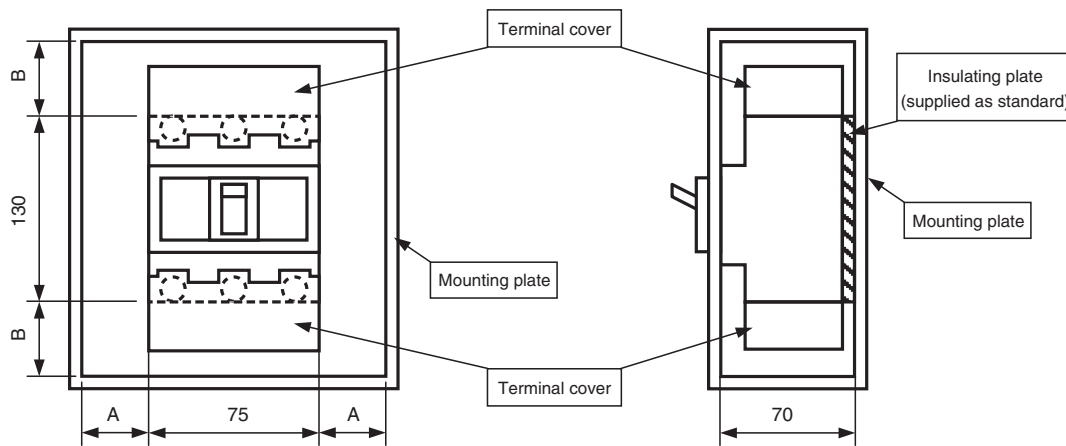

Rear-connected

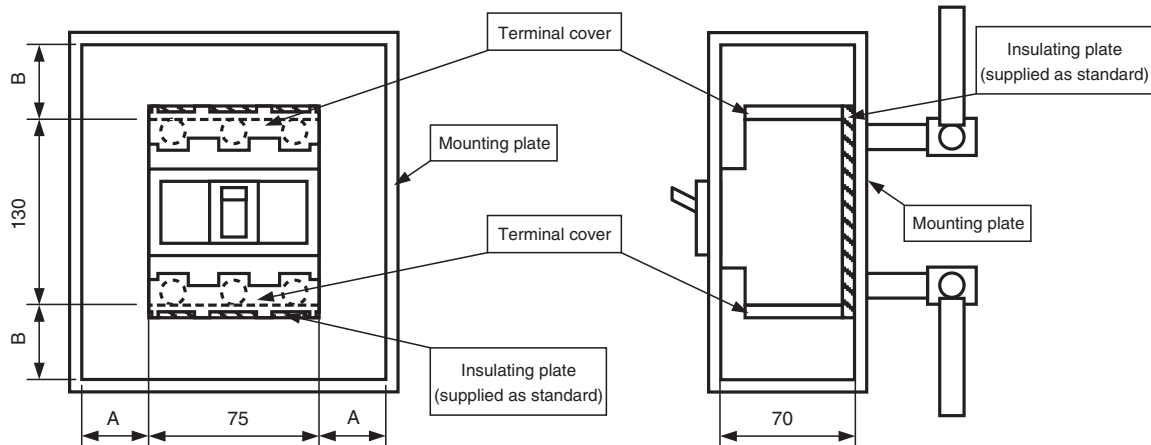

Type	Connection	Minimum insulation distance (mm)		Insulating plate	
		A	B	Terminal cover	Insulating plate
PVE160-SDL 3P	Front-connected Rear-connected	25	50	2pcs are supplied for line and load side as standard.	1pc of 130mm×75mm for F.C. or 140mm×75mm for R.C. is supplied as standard.

PVS160-SDL 3P, PVS250-SDL 3P, PVS250-SNL 3P

Front-connected

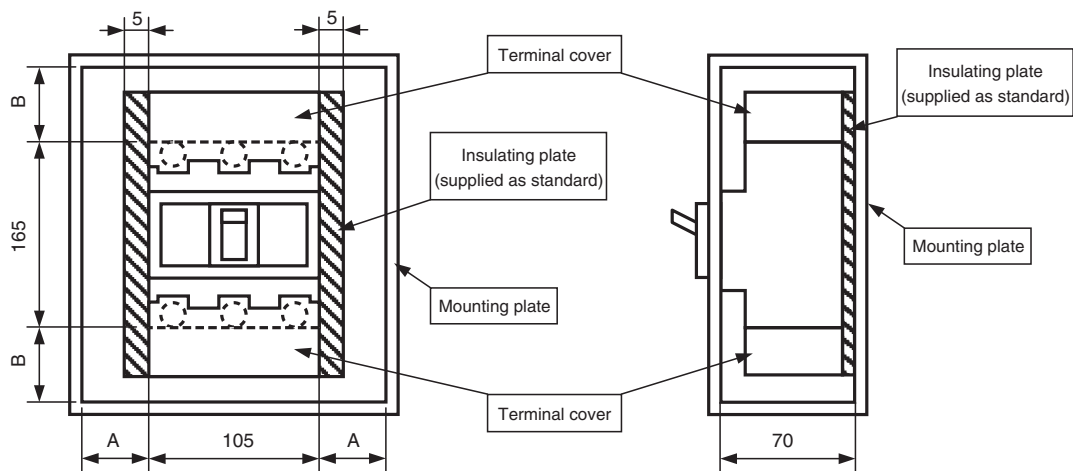

Rear-connected

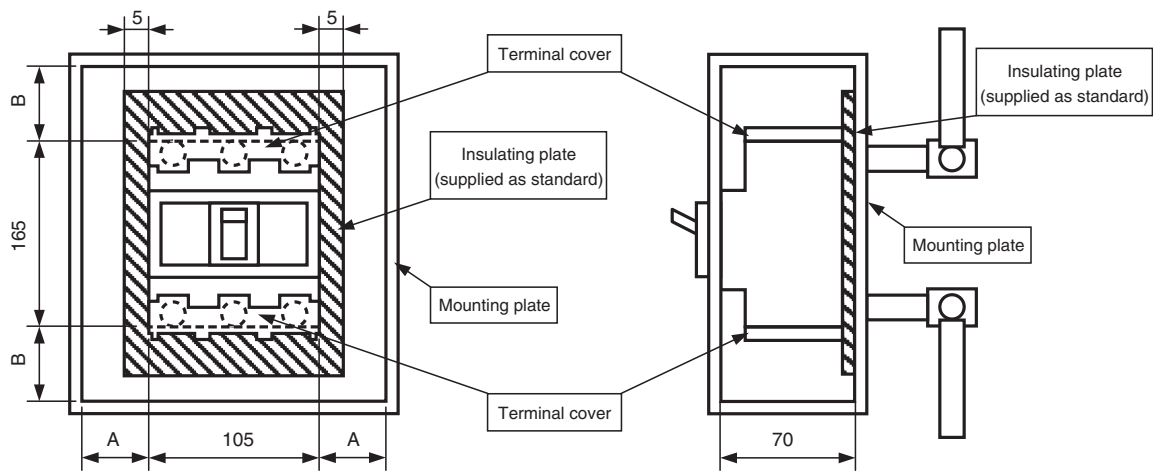

Type	Connection	Minimum insulation distance (mm)		Insulating plate	
		A	B	Terminal cover	Insulating plate
PVS160-SDL 3P PVS250-SDL 3P PVS250-SNL 3P	Front-connected Rear-connected	50	65	2pcs are supplied for line and load side as standard.	2pcs of 115mm × 137.5mm are supplied as standard.

Insulation distance DC750V-1000V

PVS160-SNL 4P, PVS250-SNL 4P

Front-connected

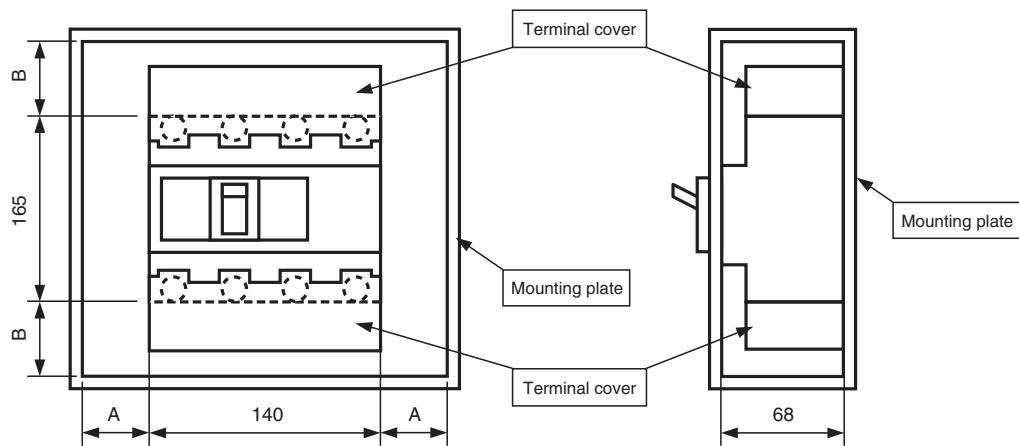

Rear-connected

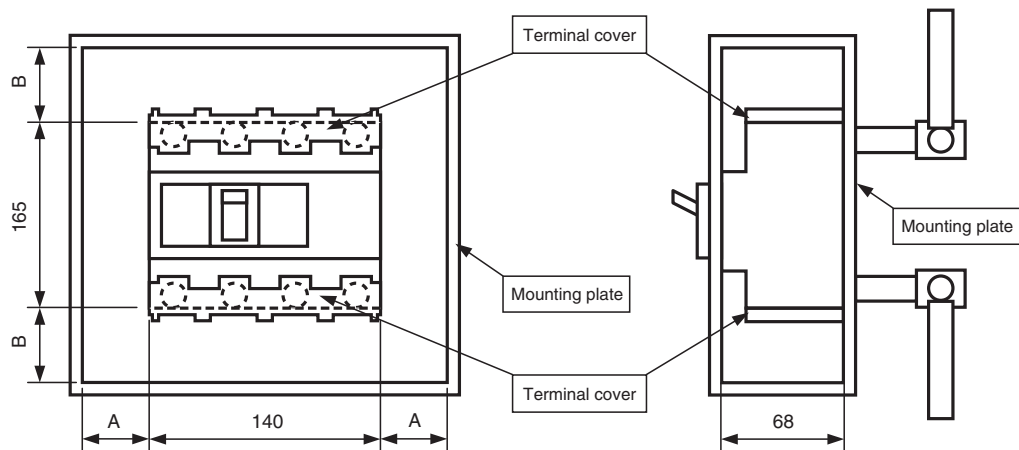

Type	Connection	Minimum insulation distance (mm)		Terminal cover
		A	B	
PVS160-SNL 4P PVS250-SNL 4P	Front-connected Rear-connected	50	65	2pcs are supplied for line and load side as standard.

PVS160-GDH 4P, PVS250-GDH 4P

Front-connected

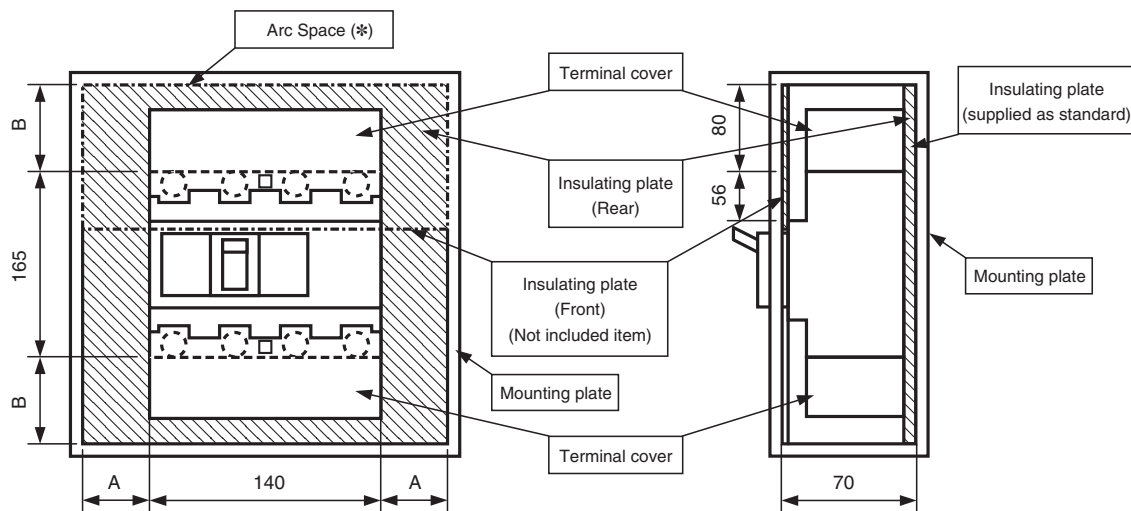

Rear-connected

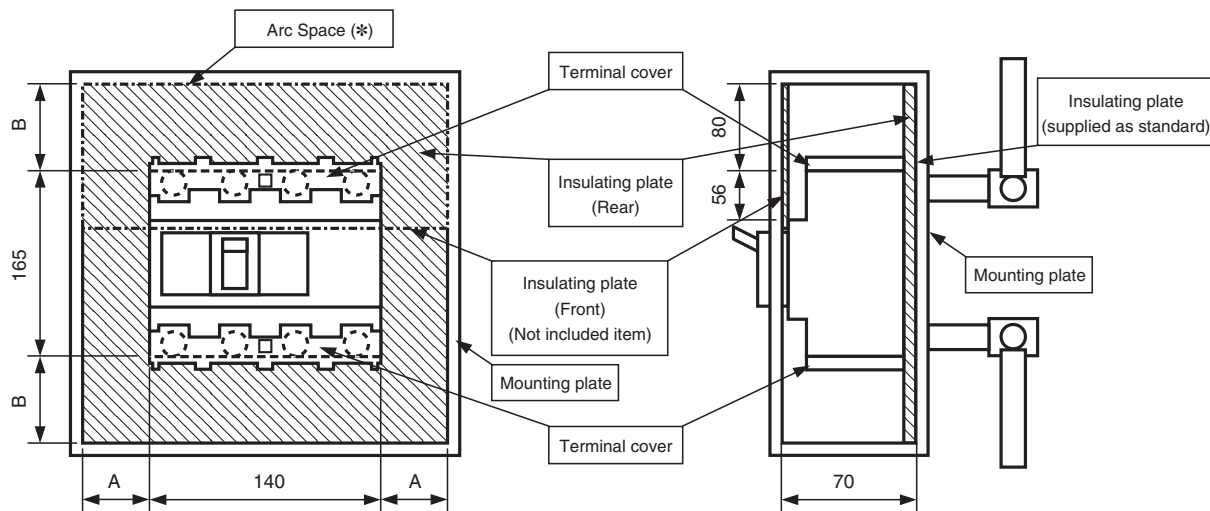

* : Arc space is the same dimension as the insulation plate (rear).

Type	Connection	Minimum insulation distance (mm)		Insulating plate		
		A	B	Terminal cover	Terminal cover lock	Insulating plate
PVS160-GDH 4P PVS250-GDH 4P	Front-connected Rear-connected	50	80	2pcs are supplied for line and load side as standard.	2pcs are supplied for line and load side as standard.	2pcs of 240mm × 162.5mm are supplied as standard.

Insulation distance DC750V-1000V

PVS160-SDH 4P, PVS250-SDH 4P

Front-connected

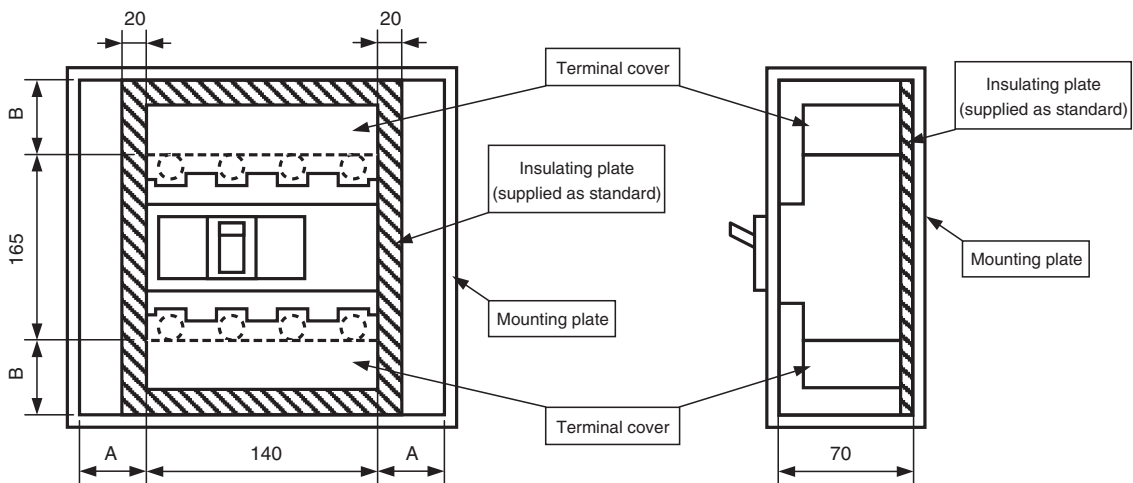

Rear-connected

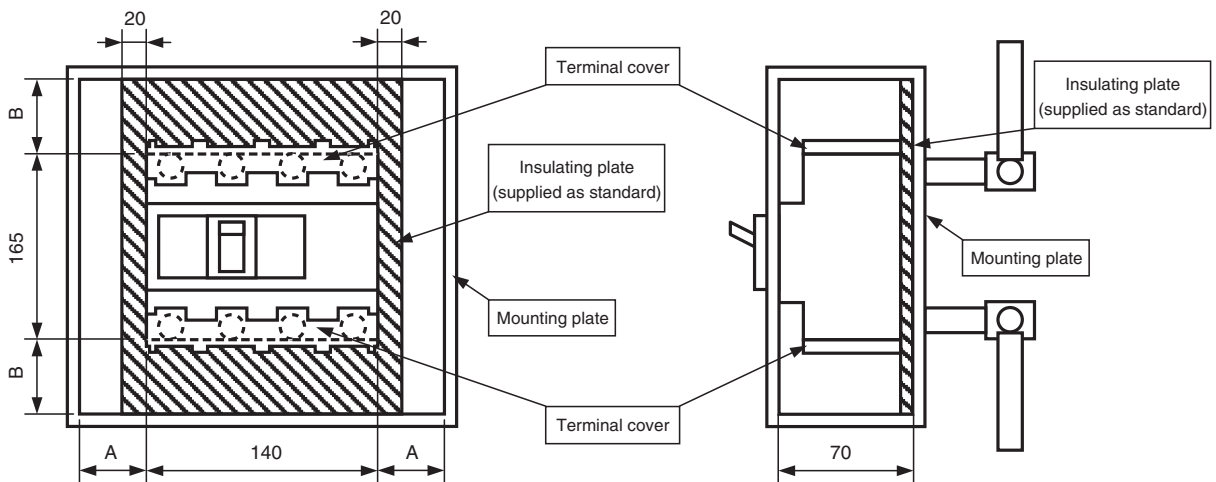

Type	Connection	Minimum insulation distance (mm)		Insulating plate	
		A	B	Terminal cover	Insulating plate
PVS160-SDH 4P PVS250-SDH 4P	Front-connected Rear-connected	50	65	2pcs are supplied for line and load side as standard.	2pcs of 180mm × 147.5mm are supplied as standard.

PVS160-SNH 4P, PVS250-SNH 4P

Front-connected

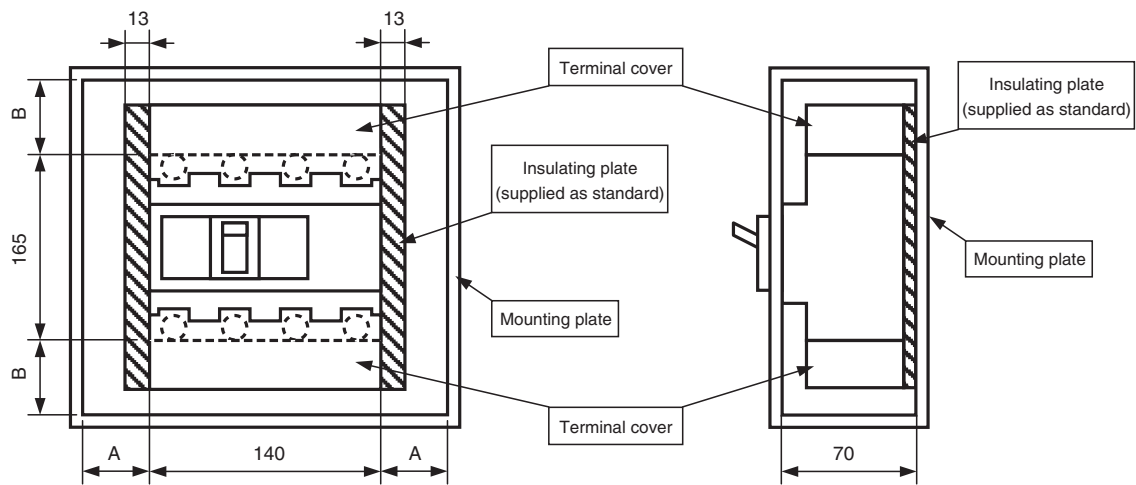

Rear-connected

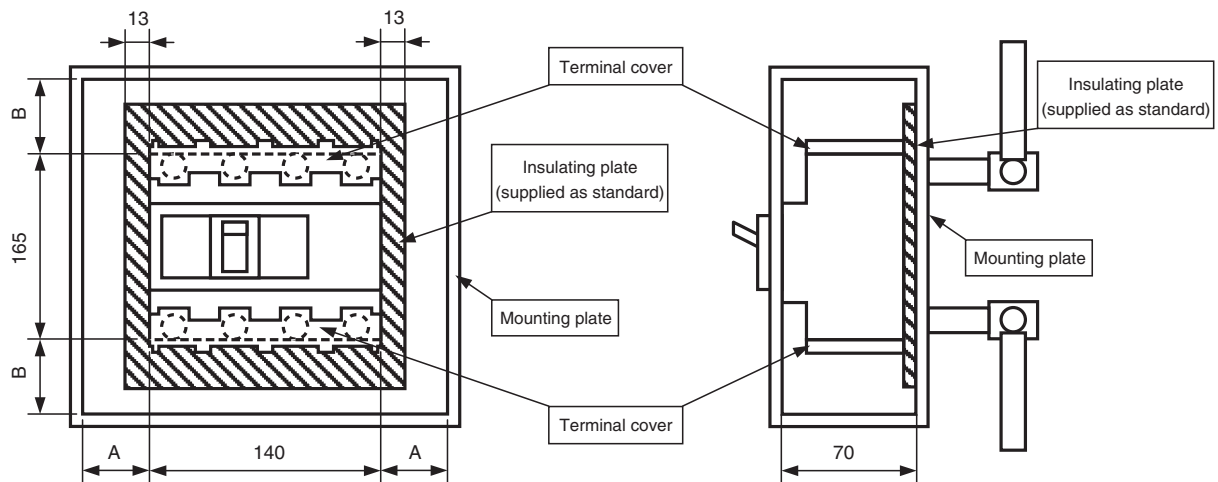

Type	Connection	Minimum insulation distance (mm)		Insulating plate	
		A	B	Terminal cover	Insulating plate
PVS160-SNH 4P PVS250-SNH 4P	Front-connected Rear-connected	30	65	2pcs are supplied for line and load side as standard.	2pcs of 166mm × 137.5mm are supplied as standard.

Insulation distance DC750V-1000V

PVS400-NDL 3P

Front-connected

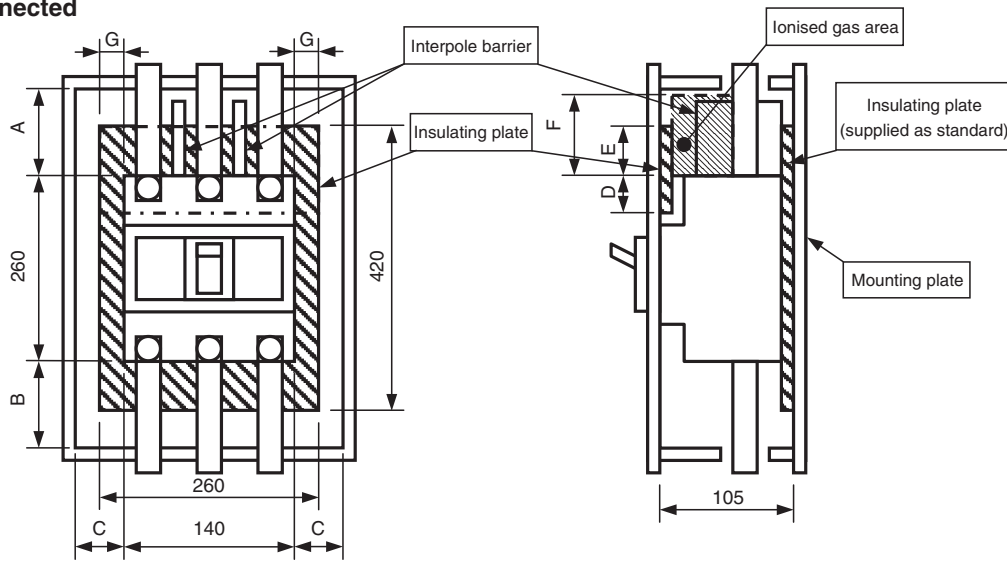

Rear-connected

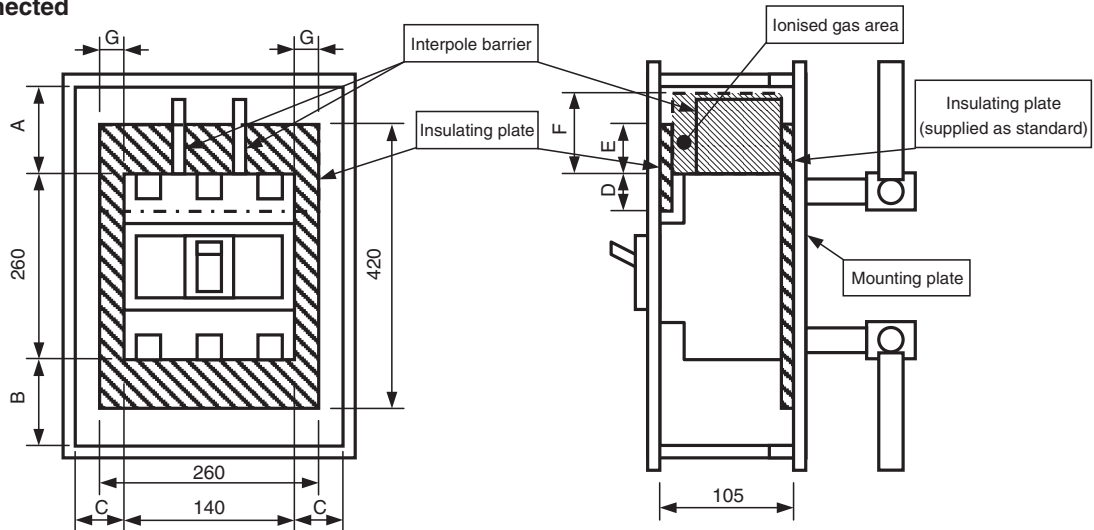

Type	Connection	Minimum insulation distance (mm)							Insulating plate	
		A	B	C	D	E	F	G	Front panel side	Mounting plate side
PVS400-NDL 3P	Front-connected Rear-connected	160	80	80	30	140	160	60	Not supplied	Supplied as standard

PVS400-NDL 4P, PVS400-NDH 4P

Front-connected

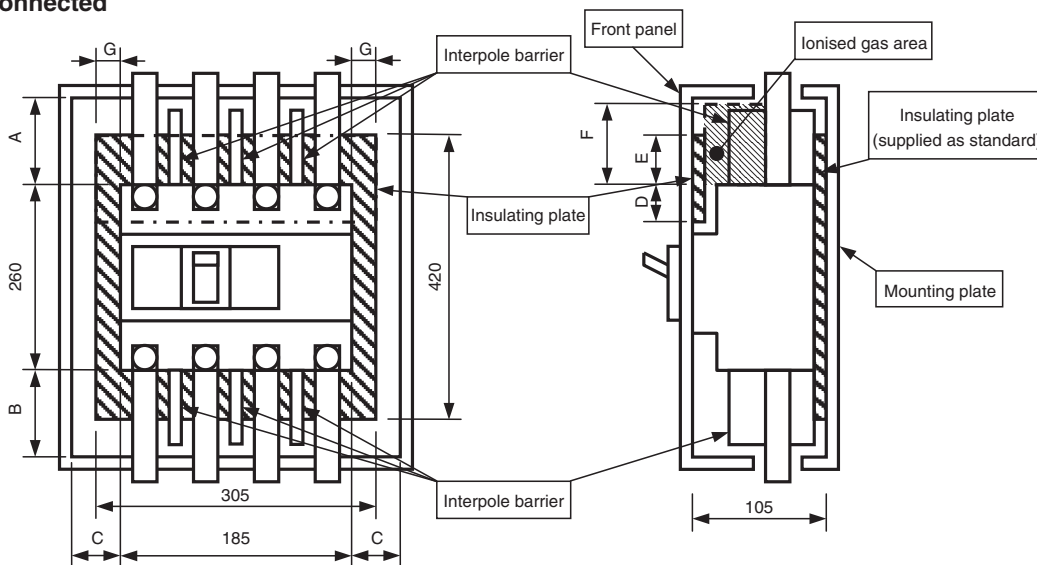

Rear-connected

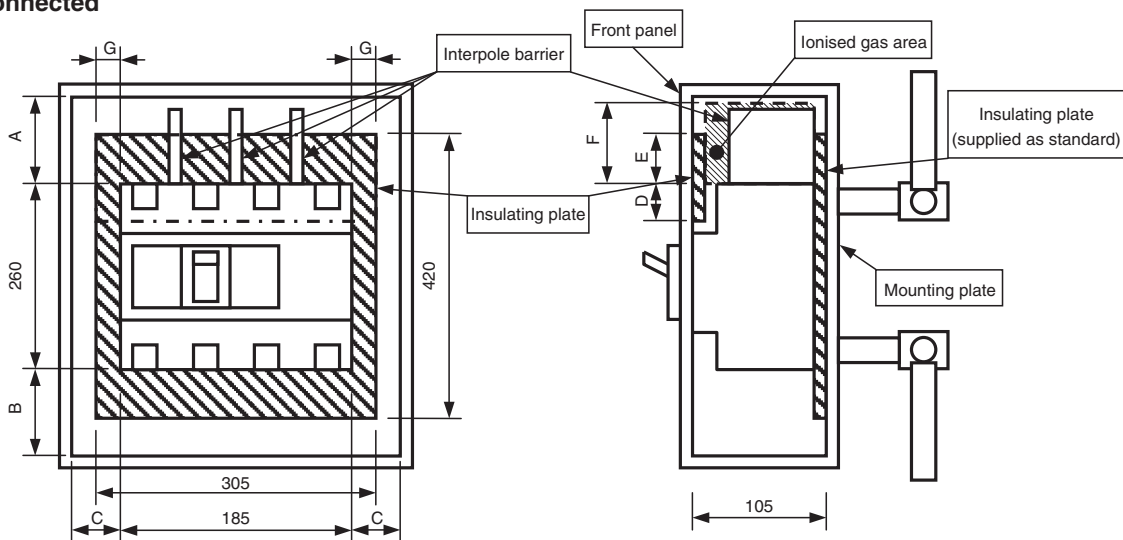

Type	Connection	Minimum insulation distance (mm)							Insulating plate	
		A	B	C	D	E	F	G	Front panel side	Mounting plate side
PVS400-NDL 4P	Front-connected	160	80	80	30	140	160	60	Not supplied	Supplied as standard
PVS400-NDH 4P	Rear-connected	160	80	80	30	140	160	60	Not supplied	Supplied as standard

Insulation distance DC750V-1000V

PVS400-NNL 3P

Front-connected

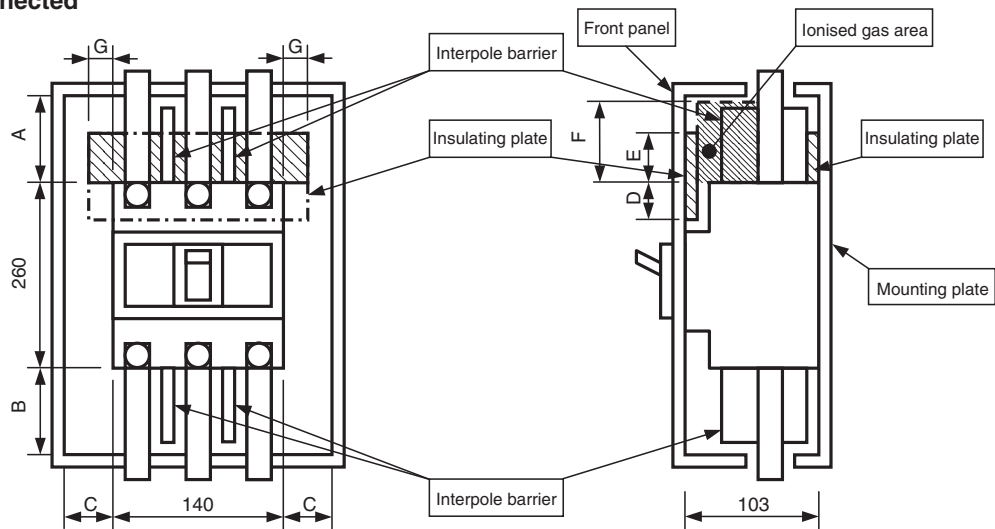

Rear-connected

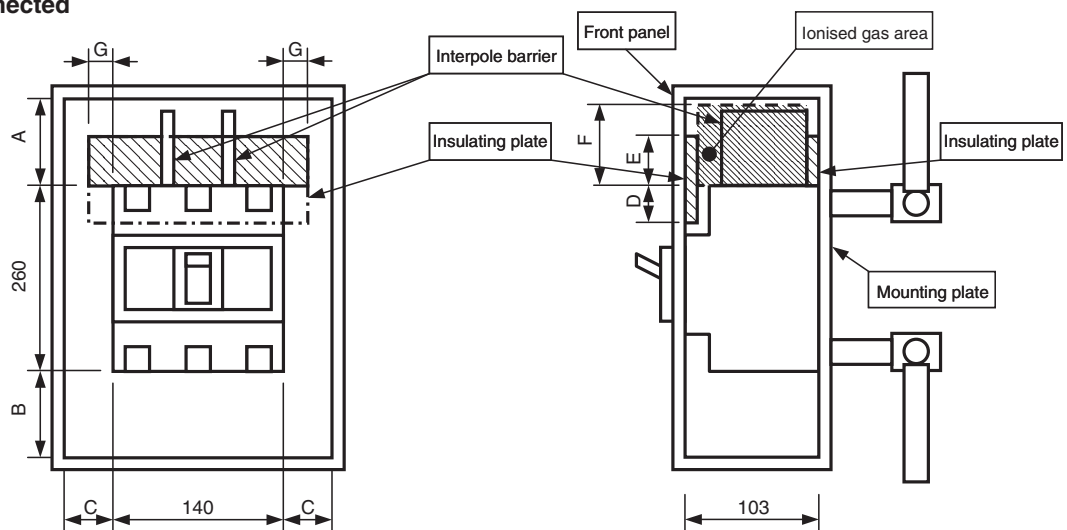

Type	Connection	Minimum insulation distance (mm)							Insulating plate	
		A	B	C	D	E	F	G	Front panel side	Mounting plate side
PVS400-NNL 3P	Front-connected Rear-connected	120	80	80	30	80	80	40	Not supplied	Not supplied

PVS400-NNL 4P, PVS400-NNH 4P

Front-connected

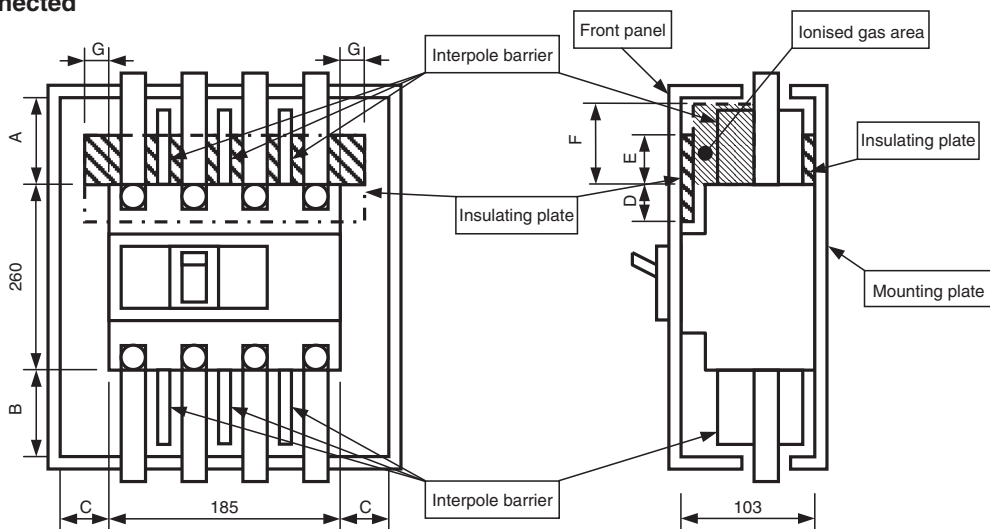

Rear-connected

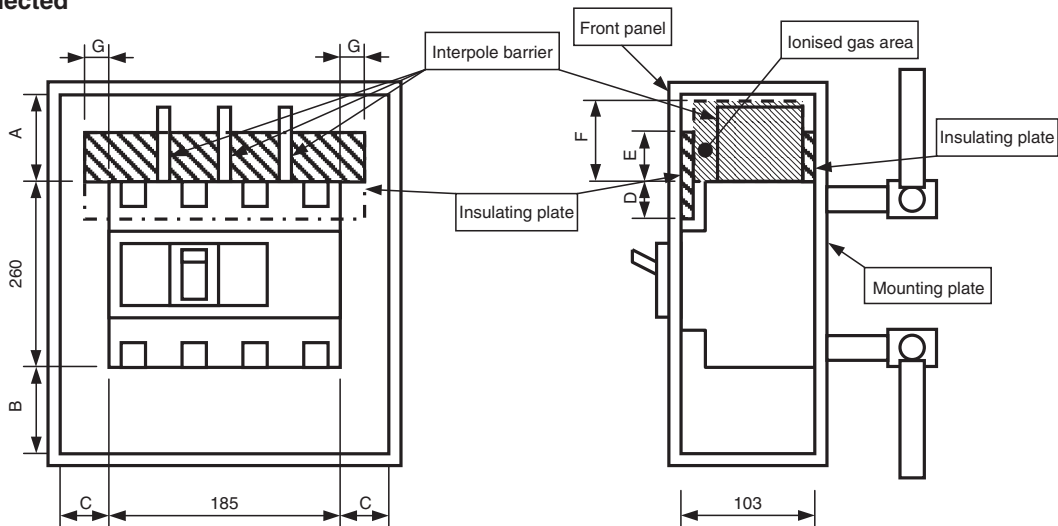

Type	Connection	Minimum insulation distance (mm)							Insulating plate	
		A	B	C	D	E	F	G	Front panel side	Mounting plate side
PVS400-NNL 4P	Front-connected	120	80	80	30	80	80	40	Not supplied	Not supplied
PVS400-NNH 4P	Rear-connected									

Insulation distance DC750V-1000V

PVS800-NDL 3P

Front-connected

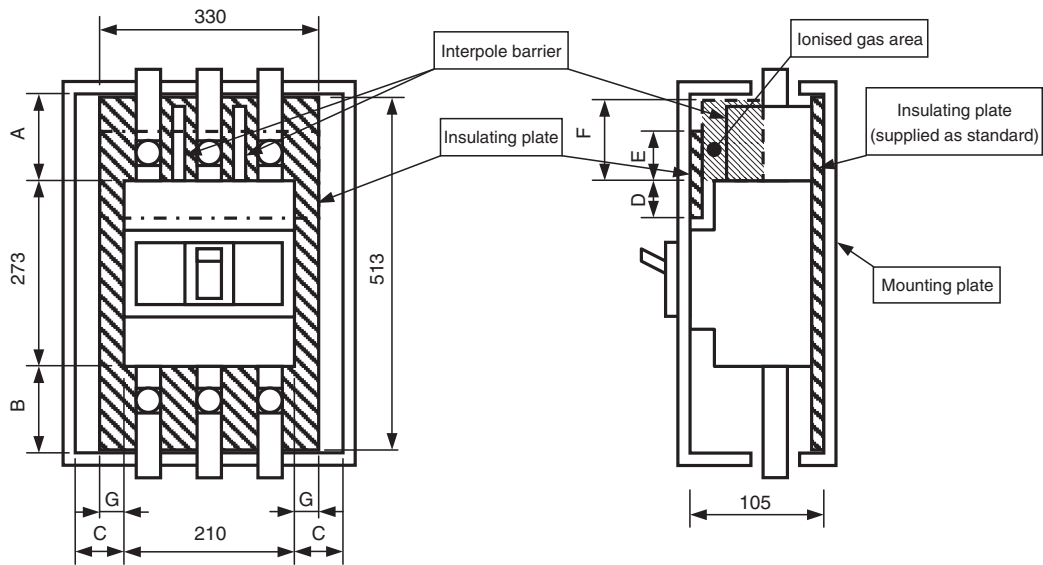

Rear-connected

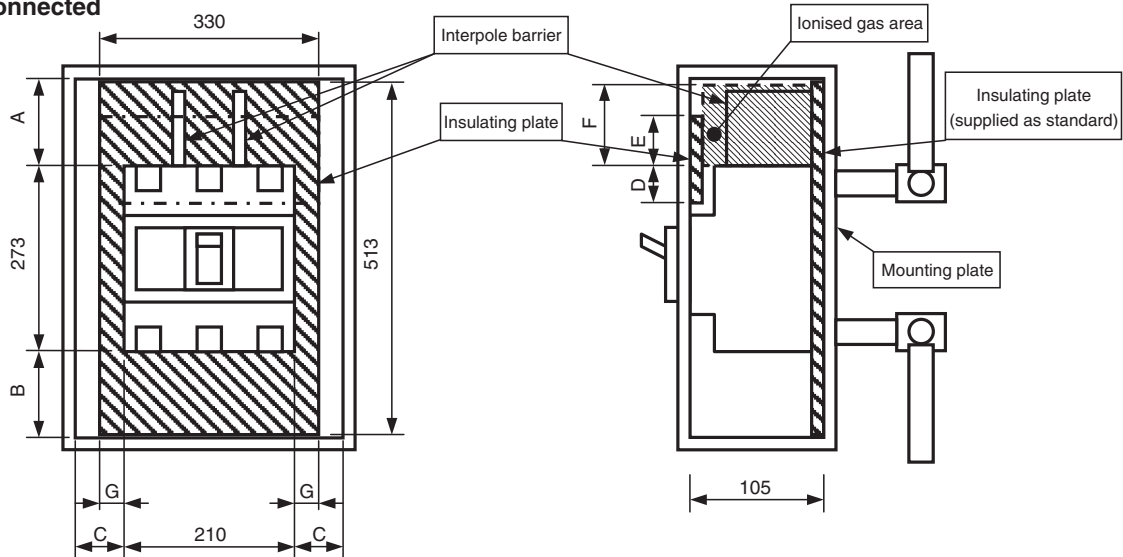

Type	Connection	Minimum insulation distance (mm)							Insulating plate	
		A	B	C	D	E	F	G	Front panel side	Mounting plate side
PVS800-NDL 3P	Front-connected Rear-connected	160	80	80	80	140	160	60	Not supplied	Supplied as standard

PVS800-NDL 4P, PVS800-NDH 4P

Front-connected

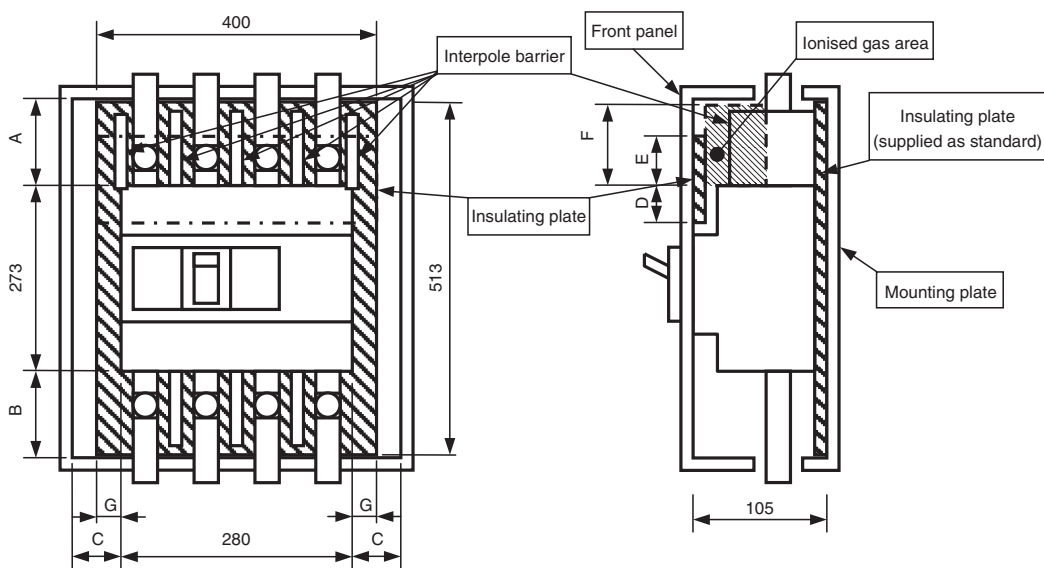

Rear-connected

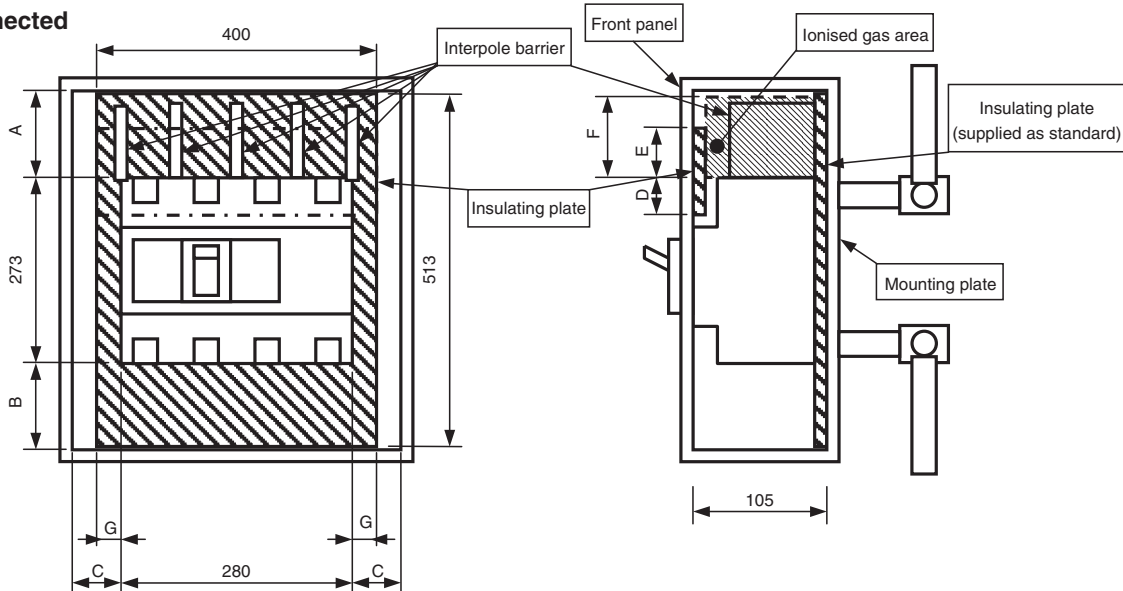

Type	Connection	Minimum insulation distance (mm)							Insulating plate	
		A	B	C	D	E	F	G	Front panel side	Mounting plate side
PVS800-NDL 4P	Front-connected	160	80	80	80	140	160	60	Not supplied	Supplied as standard
PVS800-NDH 4P	Rear-connected	160	80	80	80	140	160	60	Not supplied	Supplied as standard

Insulation distance DC750V-1000V

PVS800-NNL 3P

Front-connected

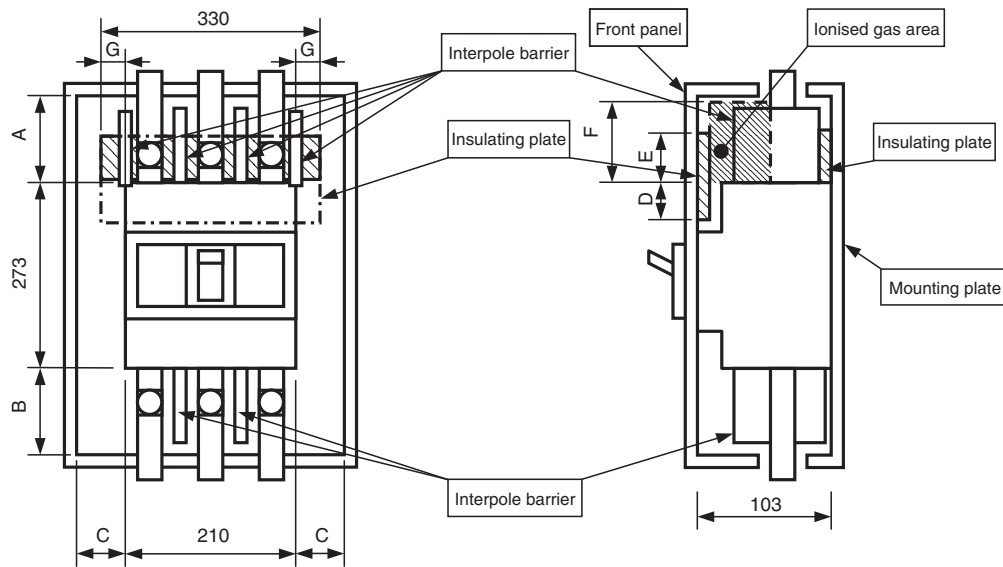

Rear-connected

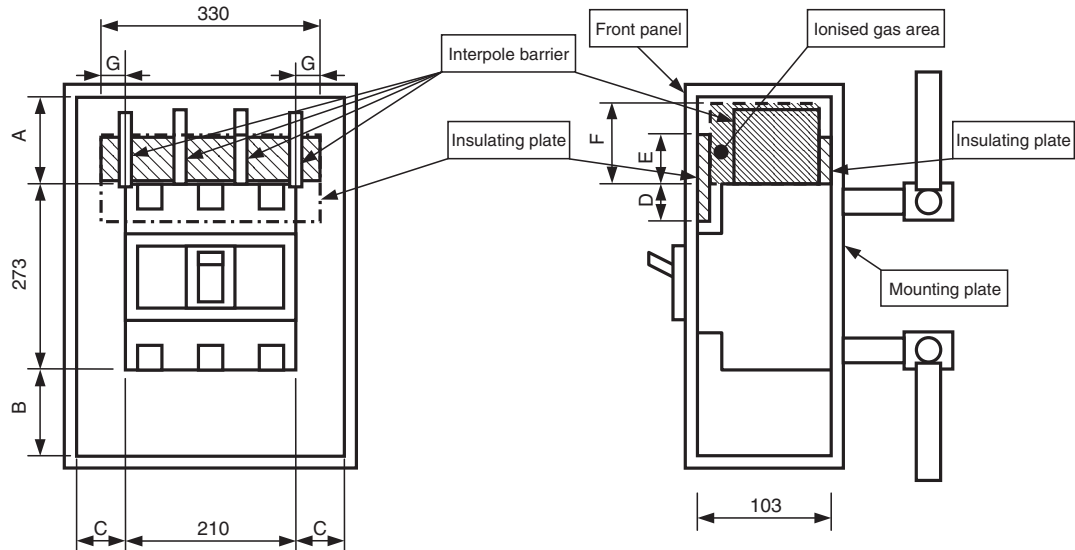

Type	Connection	Minimum insulation distance (mm)							Insulating plate	
		A	B	C	D	E	F	G	Front panel side	Mounting plate side
PVS800-NNL 3P	Front-connected Rear-connected	120	80	80	80	80	80	60	Not supplied	Not supplied

PVS800-NNL 4P, PVS800-NNH 4P

Front-connected

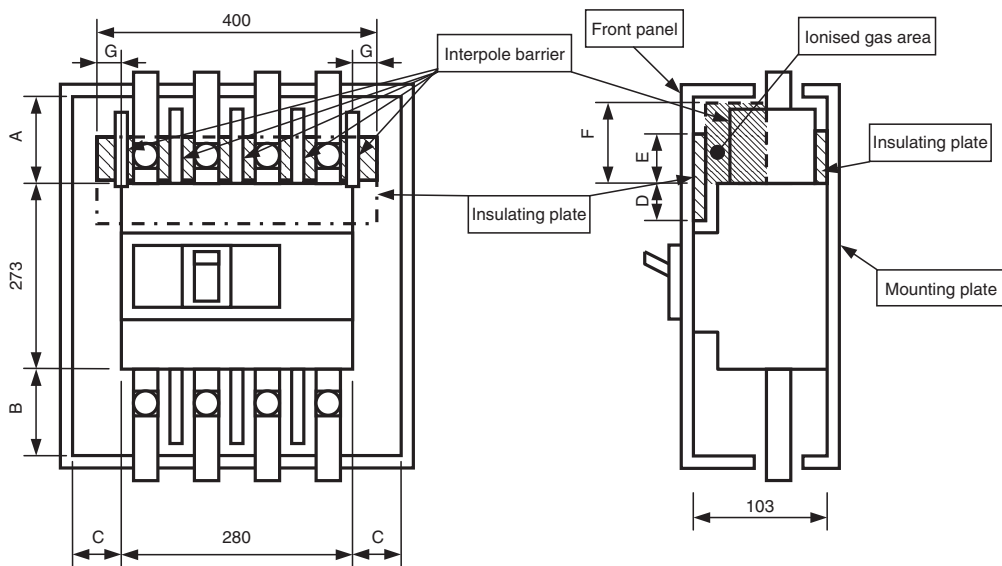

Rear-connected

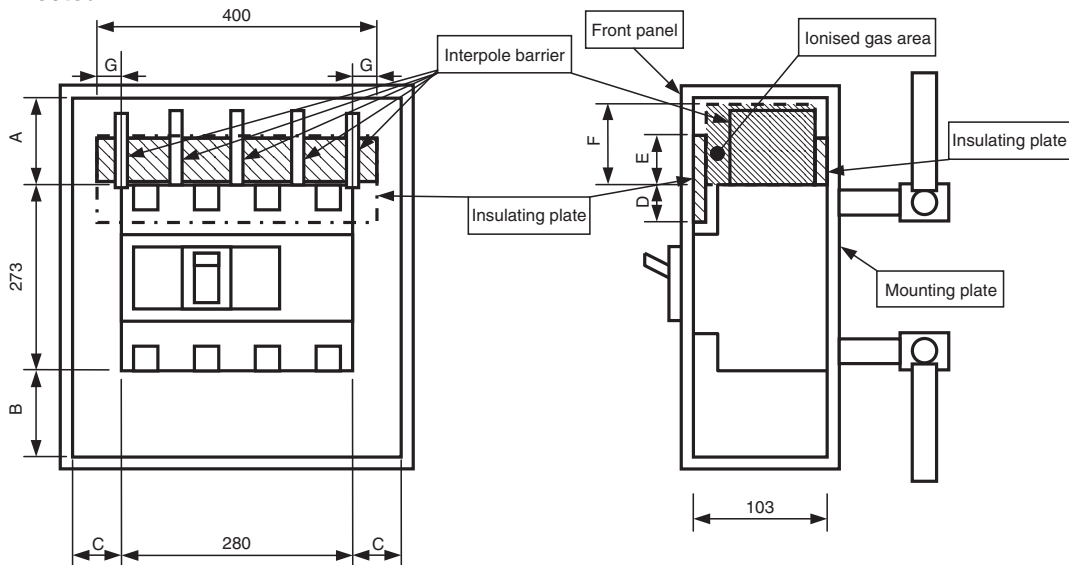

Type	Connection	Minimum insulation distance (mm)							Insulating plate	
		A	B	C	D	E	F	G	Front panel side	Mounting plate side
PVS800-NNL 4P	Front-connected	120	80	80	80	80	80	60	Not supplied	Not supplied
PVS800-NNH 4P	Rear-connected									

5

Accessories

Internally mounted accessories

- 1. Connection diagrams and terminal numbers5-2
- 2. Possible combinations5-3
- 3. Ratings data of auxiliary and alarm switches.....5-4
- 4. Shunt trip device (SH)5-4
- 5. Undervoltage trip device (UV).....5-4

Externally mounted accessories

- 1. Motor operators (MC)5-6
- 2. External operating handles5-12
 - (1) Breaker-mounted (field installable small type) (HB)5-12
 - (2) Door-mounted (depth adjustable) (HP)5-20
- 3. Toggle holder (HH) and toggle lock (HL)5-27
- 4. Terminal covers5-28
- 5. Terminal blocks (TF)5-32

Internally mounted accessories

1. Connection diagrams and terminal numbers

Accessory	Combination symbol	Connection diagram and terminal No.	Remarks
Shunt trip device (SH)		<ul style="list-style-type: none"> With anti-burn switch 	Applicable to MCCB type of "XS". Shunt trips are fitted with anti-burn switches.
		<ul style="list-style-type: none"> Without anti-burn switch 	Applicable to TemBreak2 breakers. Shunt trips are continuous rating without anti-burn switches.
Undervoltage trip device (UV)			Applicable to Tem Breakers2.
		For DC 	Applicable to XS1250ND and XS1600ND.
Auxiliary switch (AX)			Ex. 1pc Aux. Switch installed.
			Ex. 2pcs Aux. Switch installed.
			Ex. 4pcs Aux. Switch installed.
			Ex. 6pcs Aux. Switch installed. This is for MCCB type of "XS".
Alarm switch (AL)			Ex. 1pc Alarm switch installed.
			Ex. 2pcs Alarm switch installed. * Special application.
			Ex. 1pc Alarm switch for MCCB type of "XS".

2. Possible combinations

Type	1000V	PVS160-SDH 4P, PVS250-SDH 4P, PVS160-SNH 4P, PVS250-SNH 4P, PVS160-GDH 4P, PVS250-GDH 4P	PVS400-NDH 4P, PVS400-NNH 4P	PVS800-NDH 4P, PVS800-GDH 4P, PVS800-NNH 4P		
	800V		PVS160-SNL 4P, PVS250-SNL 4P	PVS400-NNL 4P	PVS800-NNL 4P	
750V	PVE160-SDL 3P	PVS160-SDL 3P, PVS250-SDL 3P, PVS250-SNL 3P	PVS400-NDL 3P, PVS400-NDL 4P, PVS400-NNL 3P	PVS800-NDL 3P, PVS800-NDL 4P, PVS800-NNL 3P		
250~600V	S160-SD 3P, S160-GD 3P, S160-SDN 3P	S250-SD 3P, S250-GD 3P, S250-SDN 3P	S400-ND 3P	S800-ND 3P, S1000-ND 2P, S1000-ND 3P	XS1250ND 2P, XS1600ND 2P, XS1250ND 3P, XS1600ND 3P	XS2000ND 2P, XS2500ND 2P, XS3200ND 2P, XS2000ND 3P, XS2500ND 3P, XS3200ND 3P
Number of poles ①	3	3	3	3	3 ②	3 ②
Combinations of accessories	AX					
	AL					
	SH					
	UV					
	AX AL					
	AX SH					
	AX UV					
	AL SH					
	AL UV					
	AX AL SH					
	AX AL UV					

Notes:

- ① : For the four-pole type, see the column for the three-pole type.
- ② : A breaker with AC UVT is provided with an external UVT controller. See page 5-5.

Internally mounted accessories

3. Ratings data of auxiliary and alarm switches

Ratings of AX and AL

• The applicable load of the switch shall be no larger than the rating and no smaller than the minimum load.

Type of breaker	Standard						For microload ①			
	AC (V)			DC (V)			Minimum load	DC (V)		Minimum load
	Voltage (V)	Current (A)		Voltage (V)	Current (A)			Voltage (V)	Current (A)	
Resistive load		Inductive load	Resistive load		Inductive load					
S160-SD, S160-GD, S160-SDN, S250-SD, S250-GD, S250-SDN, S400-ND, S800-ND, S1000-ND, PVE160-SDL, PVS160-SDL, PVS250-SDL, PVS160-SNL, PVS250-SNL, PVS160-SDH, PVS250-SDH, PVS160-SNH, PVS250-SNH, PVS160-GDH, PVS250-GDH, PVS400-NDL, PVS400-NNL, PVS400-NDH, PVS400-NNH, PVS800-NDL, PVS800-NNL, PVS800-NDH, PVS800-GDH, PVS800-NNH	480	—	—	250	—	—	DC15V 100mA	30	0.1	DC5V 1mA
	250	3	2	125	0.4	0.05				
	125	3	2	30	3	2				
XS1250ND, XS1600ND, XS2000ND, XS2500ND, XS3200ND	480	3	2	250	0.3	0.3	DC5V 160mA DC30V 26.7mA	30	0.1	DC5V 1mA DC30V 1mA
	250	5	5	125	0.6	0.6				
	125	5	5	30	5	4				

Note: ① This is a custom-made product. When ordering for this product, specify that it is intended for microload use.

Note: ② The inductive load means power factor of no smaller than 0.4 for AC and time constant of no larger than 7 ms for DC.

4. Shunt trip device (SH)

Ratings of SHT

Type of breaker	Rated voltage	Peak exciting current, A						Connection diagram and terminal No.
		AC (V)			DC (V)			
		100-120	200-240	380-450	24	48	100-120	200-240
S160-SD, S160-GD, S160-SDN, S250-SD, S250-GD, S250-SDN, S400-ND, S800-ND, S1000-ND, PVE160-SDL, PVS160-SDL, PVS250-SDL, PVS160-SNL, PVS250-SNL, PVS160-SDH, PVS250-SDH, PVS160-SNH, PVS250-SNH, PVS160-GDH, PVS250-GDH, PVS400-NDL, PVS400-NNL, PVS400-NDH, PVS400-NNH, PVS800-NDL, PVS800-NNL, PVS800-NDH, PVS800-GDH, PVS800-NNH	0.014	0.014	0.0065	0.03	0.03	0.011	0.011	 Without anti-burn swi

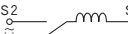
Type of breaker	Rated voltage	Peak exciting current, A (AC 60Hz)						Connection diagram and terminal No.
		AC (V)			DC (V)			
		100-115	200-480	24	48	100-115	200-230	
XS1250ND, XS1600ND	1.1	0.93	2.52	1.55	0.67	0.35	 With anti-burn switch	
XS2000ND, XS2500ND, XS3200ND	1.1	0.4 (AC200-240V) 0.93 (AC380-480V) ③	2.52	1.55	0.67	0.35		

Notes:

③: Exclusive use for 200V class and 400V class.

(1) The permissible voltage range is from 70% to 110% of the rated voltage. Ensure that the voltage does not drop exceeding the permissible voltage range when SHT is actuated.

(2) Breaker contacts usually start opening within 30 ms after the rated voltage is applied to the breaker.

5. Undervoltage trip device (UV)

(1) Ratings of UVT with Inst

Type of breaker	Rated voltage	Power supply capacity, VA ①				Exciting current, mA ①			Connection diagram and terminal No.
		AC (V)				DC (V)			
		100-120	200-240	380-450	24	100-120	200-240		
S160-SD, S160-GD, S160-SDN, S250-SD, S250-GD, S250-SDN, PVE160-SDL, PVS160-SDL, PVS250-SDL, PVS160-SNL, PVS250-SNL, PVS160-SDH, PVS250-SDH, PVS160-SNH, PVS250-SNH, PVS160-GDH, PVS250-GDH	1.4	1.5	2.3	23	10	3.5			
S400-ND, PVS400-NDL, PVS400-NNL, PVS400-NDH, PVS400-NNH	1.4	2.8	2.3	23	10	10			

Note: ①: No UVT controller is required.

(1) Tripping voltage is from 35% to 70% of the rated voltage. Resettable voltage is 85% or less of the rated voltage.

Type of breaker	Rated voltage	Power supply capacity, VA ①						Exciting current, mA ①			Connection diagram and terminal No.
		AC (V)						DC (V)			
		100-110	115-120	200-220	230-240	380-415	440-450	24	100-120	200-240	
S800-ND, S1000-ND, PVS800-NDL, PVS800-NNL, PVS800-NDH, PVS800-GDH, PVS800-NNH	1.5	1.6	2.4	2.9	2.1	2.3	29	13	11		

Note: ①: No UVT controller is required.

(1) Tripping voltage is from 35% to 70% of the rated voltage. Resettable voltage is 85% or less of the rated voltage.

(2) Ratings of UVT with Inst

Type of breaker	Power supply capacity, VA ①			Exciting current, mA ①			Connection diagram and terminal No.
	Rated voltage	AC (V)			DC (V)		
		100-120	200-240	380-450	24	100-115	200-230
XS1250ND, XS1600ND	—	—	—	26	9.2	48	
XS2000ND, XS2500ND, XS3200ND	—	—	—	—	—	—	

Notes: ①: No UVT controller is required.

(1) Tripping voltage is from 35% to 70% of the rated voltage.

Resettable voltage is 85% or less of the rated voltage.

(2) The UVT consists of a tripping mechanism and mechanism of maintain handle at OFF position when without the control voltage.

Please reset the breaker before turning the handle to ON position.

Externally mounted accessories

1. Motor operators (MC)

(1) T2MC

Feature

★ Installation and removal ease

T2MC25L: Simply rotate two knobs allows the motor operator to be installed on or removed from the breaker.

T2MC40/80: The compact and lightweight design enables easy installation and removal.

★ High-speed, stable actuation

The operating time as short as up to 0.1 second makes it possible to use the motor operators for synchronized closing of breakers.

★ Silent operation

T2MC25L use a direct drive system, providing operational silence.

★ “Lock-in off” capability

This capability allows the breaker to be padlocked in the OFF state. Up to three padlocks with a 5 to 8 mm hasp diameter can be used. Padlocks are not supplied.

Motor driven type

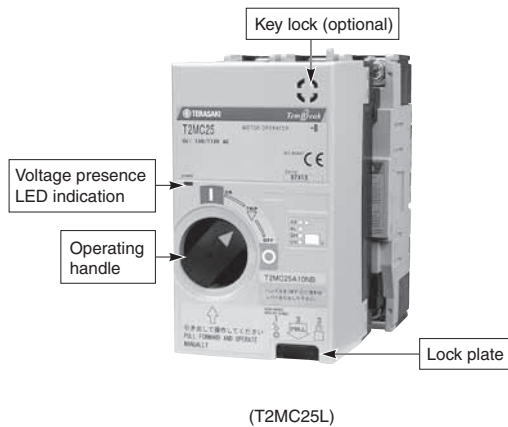

(T2MC25L)

Spring charged type

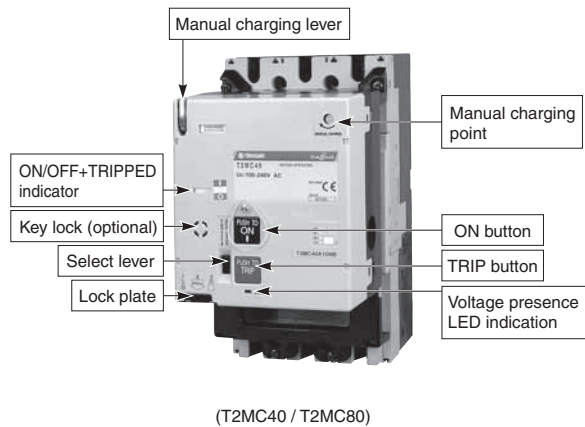

(T2MC40 / T2MC80)

Ratings and Specifications

	T2MC25L	T2MC40	T2MC80
Type of breaker	S250-SD, S250-GD, S250-SDN, PVS160-SDL, PVS250-SDL, PVS160-SNL, PVS250-SNL, PVS160-SDH, PVS250-SDH, PVS160-SNH, PVS250-SNH, PVS160-GDH, PVS250-GDH	S400-ND, PVS400-NDL, PVS400-NNL, PVS400-NDH, PVS400-NNH	S800-ND, S1000-ND, PVS800-NDL, PVS800-NNL, PVS800-NDH, PVS800-GDH, PVS800-NNH
Rated operational voltage ①	●AC100-110V ●DC24V ●DC100-110V ●AC200-220V ●DC48V ●DC200-220V ●AC230-240V	●AC100-240V ●DC24-48V ●DC100-120V	●AC100-240V ●DC24-48V ●DC100-120V
Peak steady-state/starting current, A ②	AC100-110V 4.5/8 AC200-220V 4/8 AC230-240V 3.5/7 DC24V 18/26 DC48V 12/18 DC100-110V 2.2/6 DC200-220V 2.2/5.5	—/2.3 (ON) 1.4/3.7 (OFF,RESET) —/2.3 (ON) 1.1/3.5 (OFF,RESET) —/2.3 (ON) 1.1/3.5 (OFF,RESET) —/7.2 (ON) 3.9/8.1 (OFF,RESET) —/7.2 (ON) 2.0/5.1 (OFF,RESET) —/2.4 (ON) 1.2/3.8 (OFF,RESET)	—/2.2 (ON) 1.7/3.5 (OFF,RESET) —/2.2 (ON) 1.3/3.5 (OFF,RESET) —/2.2 (ON) 1.3/3.5 (OFF,RESET) —/12 (ON) 6.0/11.5 (OFF,RESET) —/7 (ON) 3.2/6.5 (OFF,RESET) —/2.2 (ON) 1.3/3.5 (OFF,RESET)
Operation method	Motor driven (direct drive system)	Spring driven	Spring driven
Operating time, s	ON 0.1	0.1	0.1
at rated voltage	OFF/RESET 0.1③④	1.5③④	1.5③④
Operating switch ratings	100V 0.1A (Open voltage/current: 44 V/4 mA)⑤	100V 0.1A (Open voltage/current: 48 V/1 mA)	100V 0.1A (Open voltage/current: 48 V/1 mA)
Power supply required	300VA or higher	300VA or higher	300VA or higher
Dielectric withstand voltage (for one minute)	AC1500V (AC 1000 V for DC 24/48 V)	AC1500V (AC 1000 V for DC 24/48 V)	AC1500V (AC 1000 V for DC 24/48 V)
Weight	1.4kg	3.5kg	3.5kg

Notes:

① : Permissible operating range is 85 to 110%. A power transformer is available as option for AC380V or AC400-460V.

② : The currents shown are the maximum values at the maximum rated operational voltage.

③ : The operating time is the value when the rated operational voltage is supplied.

Loss of the control power in this operating time may cause the motor operator to fail to work.

④ : The motor operator is of a short time duty. Do not subject it to more than 10 continuous ON-OFF operations. If this occurs, allow the motor operator to cool for at least 15 minutes.

⑤ : When the rated operational voltage is DC24V the open voltage will be DC22V.

Motorized operation

The motor operator has an input-signal self-hold circuit; closing the ON or OFF switch (see circuit diagrams shown below) momentarily allows activating the motor operator. To reset the tripped breaker to the OFF position, close the OFF (RESET) switch.

The voltage presence LED indication is on when the power is supplied to the motor operator.

Auto reset feature (optional)

The auto reset feature allows the breaker to be automatically reset approx. 1.5 seconds after the breaker trips open. This option contains auto-reset switches and does not require to use auxiliary or alarm switches installed in the breaker.

Note 1: that after the thermal OCR trips a thermal-magnetic breaker, the breaker cannot be immediately closed though it can be auto-reset. Wait for a few minutes after the tripping and provide a close signal to the breaker.

Note 2: Do not use an alarm switch to reset breakers.

This option resets the tripped breaker automatically, regardless of the cause of the tripping.

Breakers position in tripped state

Breakers position when the breaker has tripped differs depending on the motor operator being of standard type or being equipped with the auto reset feature (optional), as shown in the table below:

T2MC25L

Cause of trip	Breakers position in tripped state	
	Standard type	With auto reset feature
Manually tripped	TRIP	○ (OFF) *
SHT/UVT		
Overcurrent		

*: The motor operator automatically provides OFF (reset) operation to the breaker.

T2MC40 / T2MC80

Cause of trip	Breakers position in tripped state	
	Standard type	With auto reset feature
Manually tripped	○ (OFF) *	○ (OFF) *
SHT/UVT	TRIP	
Overcurrent		

*: The motor operator automatically provides OFF (reset) operation to the breaker.

Manual operation

T2MC25L: Pull the operating handle out. Rotating the handle counterclockwise turns ON the breaker and clockwise turns OFF or resets the breaker.

T2MC40/80 : Switch to Manual operation from Motorized operation by Select lever. Use the spring charging handle to charge the spring and press the ON or TRIP button.

T2MC40/80 : When the TRIP button is pressed while the control power is supplied, the breaker turns OFF and if equipped with an alarm switch, it provides an output signal.

Press the TRIP button all the way in. Pressing the TRIP button halfway causes the breaker to go off without tripping, resulting in no alarm signal delivered even if the breaker is equipped with an alarm switch.

Operation precautions

1. Ensure that the actual operation voltage ranges from 85% to 110% of the rated one.
2. Use operation switches whose ratings and power capacity is as specified in the "Ratings and Specifications" table on the previous page.
3. Ensure an operating time of 50 msec or more when operating switches to turn on/off the breaker. A shorter operating time may result in failure in operating the breaker. In such a case, repeat the operation.
4. Do not continuously apply ON/OFF operating signals. ON/OFF signals must be separated by 0.3 sec or more. With the T2MC40/80, OFF and RESET operations must be 1.5 sec or more apart.
5. With the T2MC25L, do not connect alarm switches (AL) to the control circuit (OFF, ON or COM terminals). Doing so may cause the motor operator to fail to work.
6. If the motor operator is used in conjunction with a shunt trip device (SH), ensure that voltage supply to the SHT is shut off after the reset operation ends.
7. To operate multiple motor operators in batch, do not directly connect their control terminals in series, but through a separate relay for each. Otherwise, sneak circuits may form and cause the operators to fail to work.
8. Use noise filters if the control power supply of the motor operator is shared by peripheral devices. Otherwise, power supply noise may cause malfunction of the peripheral devices.

Control circuit diagrams of motor operators

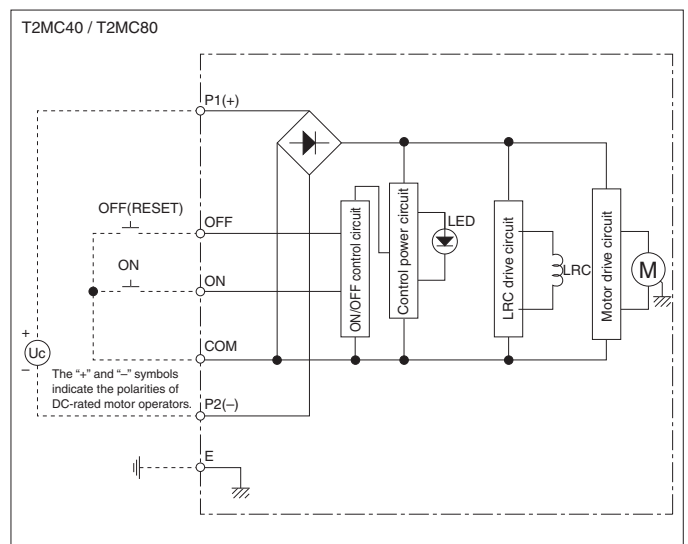
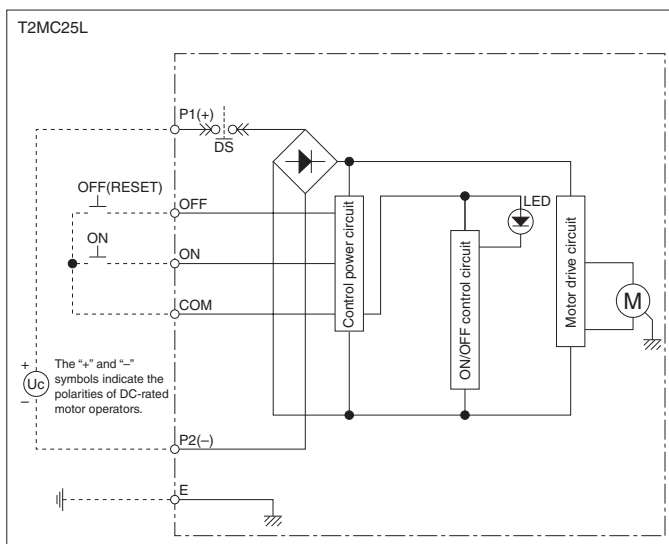

Externally mounted accessories

1. Motor operators (MC)

(2) T1MC

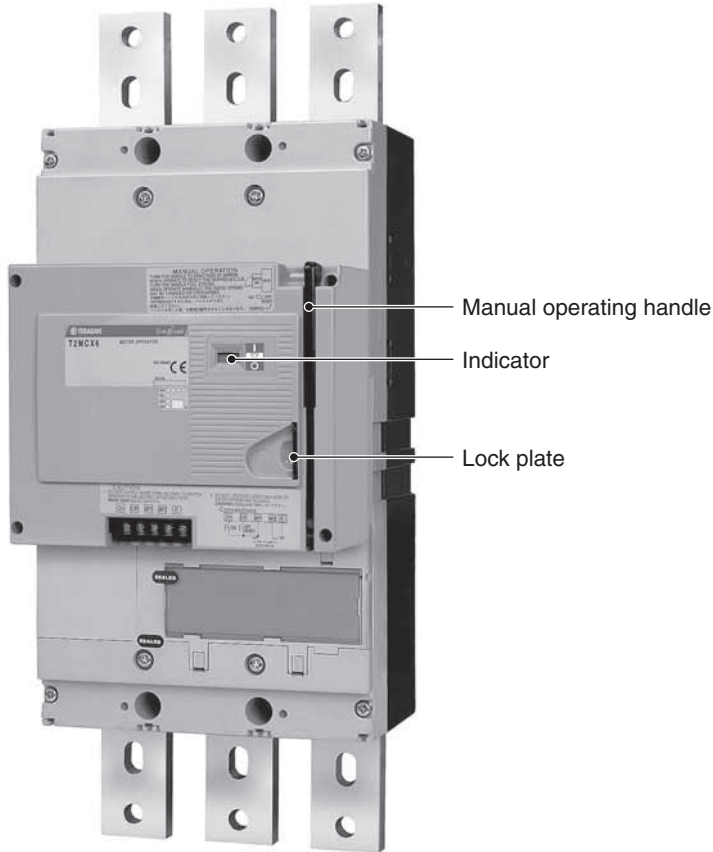

(T1MCX6)
Spring charged type

Ratings and Specifications

		T1MCX6	
Applicable breakers		XS1250ND, XS1600ND	
Rated operational voltage ①		<ul style="list-style-type: none"> ● AC100-115V ● AC200-230V ● DC100-110V ● DC24V 	
Peak steady-state/ starting current, A ②	AC100-115V	ON	—/3.1
		OFF, RESET	1.8/6.0
	AC200-230V	ON	—/1.2
		OFF, RESET	1.0/3.2
	DC100-110V	ON	—/0.8
		OFF, RESET	1.1/4.2
DC24V	ON	—/4.5	
	OFF, RESET	4.0/12.0	
Operation method		Spring charged	
Operating time, s @ rated voltage	ON (Max)	0.06	
	OFF/RESET	3 ③	
Power supply required		300VA	
Dielectric withstand voltage (for one minute)		AC1500V ④	
Weight		6.4kg	

Notes:

- ① : Permissible operating range is 85 to 110%. A power transformer is available as option for AC380V or AC400-460V.
- ② : The currents shown are the maximum values at the maximum rated operational voltage.
- ③ : The operating time is the value when the rated operational voltage is supplied.
Loss of the control power in this operating time may cause the motor operator to fail to work.
- ④ : Dielectric withstand voltage for DC 24 V motor is AC 500 V.

Features

★ Clear status indication

Color indication: Red means ON, green OFF and white TRIPPED.

★ Quick closing

Energy in a charged spring closes the breaker 60 msec or less.

High-speed, time-stable operation is ensured after multiple times of closing cycles.

★ Equipped with anti-pumping circuit

When the closing signal is applied, TRIP-RESET-ON cycles are not repeated even though the cause of tripping is in the breaker.

★ Ease of manual ON-OFF operation

Simply pressing the ON or OFF button closes or opens the breaker.

★ “Lock-in off” capability

This capability allows the breaker to be padlocked in the OFF state. Padlocks are not supplied.

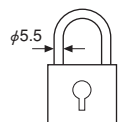

Operation mechanism

Motorized operation

■Breaker ON

Closing the ON switch activates the latch release coil (LRC), thereby releasing the closing spring to turn the breaker ON.

■Breaker OFF (RESET)

Closing the OFF/RESET switch activates the (Y) control relay, thereby starting the motor to turn the breaker OFF. At the same time, the closing spring is charged. The motor is deenergized when the breaker turns OFF (RESET).

■Breaker auto-reset (optional)

The auto-reset option uses an auto-reset switch (alarm switch) through which the closing spring is charged and the breaker is reset automatically after the breaker trips open. This option both for XMD and T2MC will be factory wired.

Notes: 1. Installable alarm switch will be only 1 piece.

2. When the breaker is equipped with the auto-reset option, a signal self-hold circuit is required because the signal provided by the alarm switch is a pulse.

Manual operation *

■Breaker ON · OFF (RESET)

Pulling down the operating lever turns the breaker ON and OFF/RESET alternately.

The handle returns to the original position when released.

※With auto-charge/discharge feature:

When manual ON operation is performed while the control power is applied, the handle switch (HS) operates to discharge the closing spring. OFF operation causes the closing spring to be charged.

When manual ON or OFF operation is performed while the control power is lost, and afterwards the control power is recovered, the closing spring is discharged or charged in the same manner as described above.

When the auto-charge/discharge action is in progress, mechanical noises will be heard. The noises however do not mean a failure.

Control circuit diagram

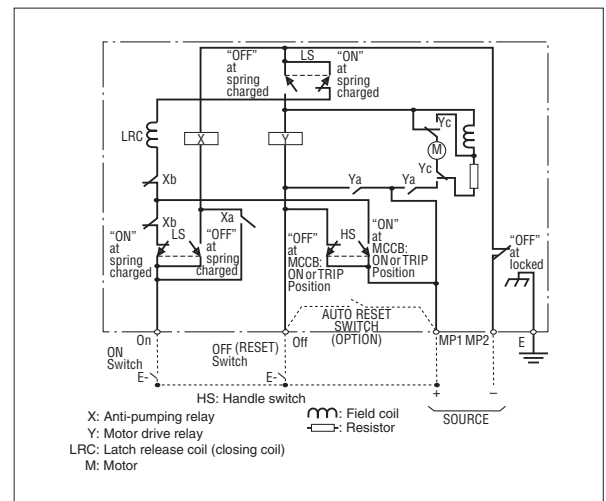

Operation Precautions

- Ensure that the actual operation voltage ranges from 85% to 110% of the rated one.
- The currents shown are the maximum values at the maximum rated operational voltage.
- When conducting the dielectric withstand voltage test, apply voltage between the control terminal group and ground. Ensure that the test voltage does not exceed AC 1500 V (AC 500 V if the rated operation voltage is DC 24 V).
- If the breaker is equipped with the UVT device, ensure that the UVT device is reset before providing a closing signal to the breaker.
- It takes up to three seconds to complete motorized OFF operation. If the breaker requires to be immediately opened from a remote location in an emergency, add the SHT or UVT device to the breaker for remote electrical tripping.
- When a thermal-magnetic breaker is tripped by the thermal OCR, wait for a few minutes; then reset the breaker.
- Make sure that the current and switching capacities of the operation switch are appropriate for the application.
- Avoid repeated and continuous applications of the operation power supply to the motor operator.
- Use noise filters if the control power supply of the motor operator is shared by peripheral devices. Otherwise, power supply noise may cause malfunction of the peripheral devices.
- Be sure to apply power to control power terminal MP1. If the breaker is turned ON or OFF manually without power applied to MP1, the auto charge/discharge feature is disabled, and thus the motor operator will not be activated next time. In such a case, applying the rated operation voltage between control power terminals MP1 and MP2 will enable the auto charge/discharge feature.

Externally mounted accessories

1. Motor operators (MC)

(3) XMB

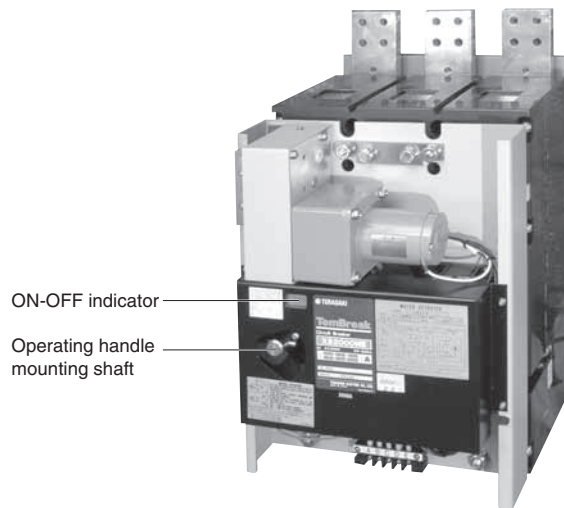

Motor driven type

Ratings and Specifications

	XMB10	XMB12																
Series/type of breaker	XS2000ND, XS2500ND	XS3200ND																
Rated operational voltage ①	<ul style="list-style-type: none"> ● AC100-110V ● AC200-220V ● DC100-110V 	<ul style="list-style-type: none"> ● AC100-110V ● AC200-220V ● DC100-110V 																
Auto reset	Optional ② Non	Optional ② Non																
Peak steady-state/ starting current, A ③	<table border="0"> <tr><td>AC100-110V</td><td>0.85/3.5</td></tr> <tr><td>AC200-220V</td><td>1.3/2.1</td></tr> <tr><td>DC100V</td><td>1.1/2.5</td></tr> <tr><td>DC110V</td><td>1.2/3.0</td></tr> </table>	AC100-110V	0.85/3.5	AC200-220V	1.3/2.1	DC100V	1.1/2.5	DC110V	1.2/3.0	<table border="0"> <tr><td>AC100-110V</td><td>0.85/3.5</td></tr> <tr><td>AC200-220V</td><td>1.3/2.1</td></tr> <tr><td>DC100V</td><td>1.1/2.5</td></tr> <tr><td>DC110V</td><td>1.2/3.0</td></tr> </table>	AC100-110V	0.85/3.5	AC200-220V	1.3/2.1	DC100V	1.1/2.5	DC110V	1.2/3.0
AC100-110V	0.85/3.5																	
AC200-220V	1.3/2.1																	
DC100V	1.1/2.5																	
DC110V	1.2/3.0																	
AC100-110V	0.85/3.5																	
AC200-220V	1.3/2.1																	
DC100V	1.1/2.5																	
DC110V	1.2/3.0																	
Operation method	Motor driven	Motor driven																
Operating time, s at rated voltage	<table border="0"> <tr><td>ON</td><td>2.0</td></tr> <tr><td>OFF/RESET</td><td>1.6④⑤</td></tr> </table>	ON	2.0	OFF/RESET	1.6④⑤	<table border="0"> <tr><td>ON</td><td>2.0</td></tr> <tr><td>OFF/RESET</td><td>1.6④⑤</td></tr> </table>	ON	2.0	OFF/RESET	1.6④⑤								
ON	2.0																	
OFF/RESET	1.6④⑤																	
ON	2.0																	
OFF/RESET	1.6④⑤																	
Operating switch ratings	250V, 5A	250V, 5A																
Power supply required	300VA or higher	300VA or higher																
Dielectric withstand voltage (for one minute)	AC1000V	AC1000V																
Weight	16kg	16kg																

- Notes:**
- ① Permissible operating range is 85 to 110%. A power transformer is available as option for AC380V or AC400-460V.
 - ② Auto reset require to use auxiliary switch (1b) installed in the breaker. If the number of auxiliary switches is insufficient, actuate an external relay via an auxiliary switch (1a) and use the relay contact (1b) for auto reset.
 - ③ The currents shown are the maximum values at the maximum rated operational voltage.
 - ④ The operating time assume the motor operator is supplied with the rated operation voltage. Loss of the motor operator to fail to work.
 - ⑤ The motor operator is short-time rated. The number of continuous switching (ON-OFF) cycles must not exceed 10. After any 10 continuous switching cycles, provide a pause of at least 15 minutes to the motor operator for cooling.

Operation mechanism

Motorized operation

■ Breaker ON

Closing the ON switch throws the motor switch from contact status “1-2” to “3-2”, thereby activating the X relay and energizing the motor operator to turn the breaker ON. When the breaker turns ON, the motor switch is thrown from contact status “3-2” to “1-2”, thereby releasing the X relay to de-energize and stop the motor operator.

■ Breaker OFF

Closing the OFF/RESET switch throws the motor switch from contact status “3-2” to “1-2”, thereby activating the Y relay and energizing the motor operator to turn the breaker OFF. When the breaker turns OFF, the motor switch is thrown from contact status “1-2” to “3-2”, thereby releasing the Y relay to de-energize and stop the motor operator.

■ Breaker RESET

To reset the tripped breaker to the OFF position, close the OFF/RESET switch.

■ Breaker auto-reset (optional)

Using the AUTO RESET auxiliary switch (1b) of the breaker allows resetting the breaker automatically when the breaker trips open.

Note: Do not use a normally closed switch as the ON switch. Doing so will result in “ON-TRIP-RESET-ON” cycles repeated unless the cause of tripping is removed.

Manual operation

Mount the operating handle onto the mounting shaft located on the front of the motor operator and rotate the shaft to turn the breaker ON or OFF. Rotating the handle anti-clockwise turns ON the breaker and clockwise turns OFF or resets the breaker. When the operating handle is mounted, the motorized operation mechanism is disengaged. Removing the handle engages the motorized operation mechanism to enable motorized operation.

■ Handle switch

With the addition of a handle switch, the motor operator mechanism can be automatically brought to the manually operated position (ON or OFF) on removal of the handle, providing that the motor operator is powered up.

Operation precautions

- When the breaker is ON and is then tripped, the ON/OFF indicator on the motor operator will indicate ON until the breaker is reset.
Note: The breaker's condition may differ.
- Use noise filters if the control power supply of the motor operator is shared by peripheral devices. Otherwise, power supply noise may cause malfunction of the peripheral devices.

Control circuit diagrams of motor operators

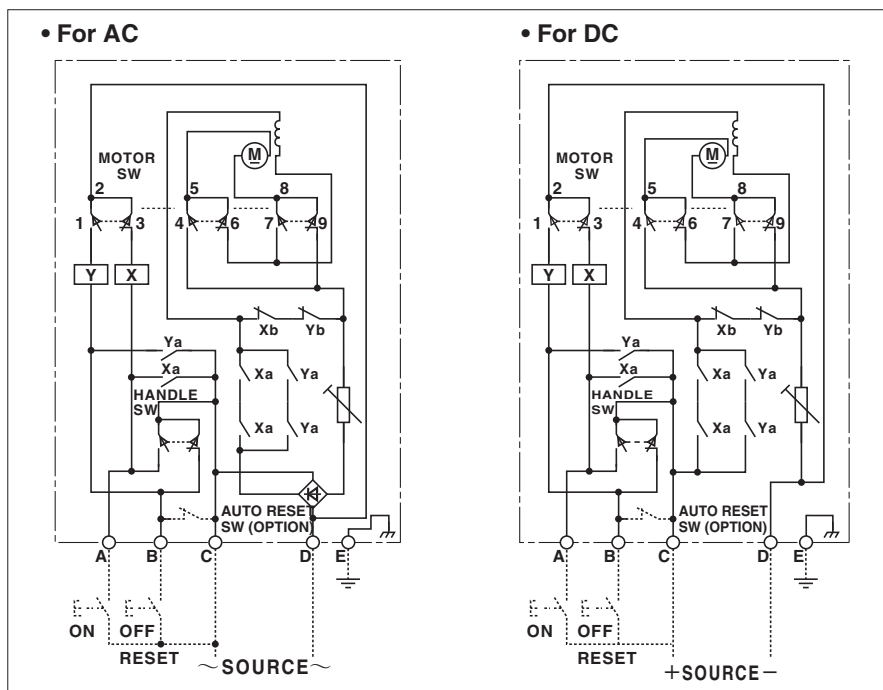

Externally mounted accessories

2. External operating handles

(1) Breaker-mounted (field installable small type) (HB)

The external operating handle is a tool that allows the breaker installed in a switchboard to be operated from outside and complies with IEC 60204-1(IEC 60204-1).

The breaker-mounted type external operating handle is designed to be mounted directly to the breaker body.

Outer view

Types
T2HB16L
T2HB25L

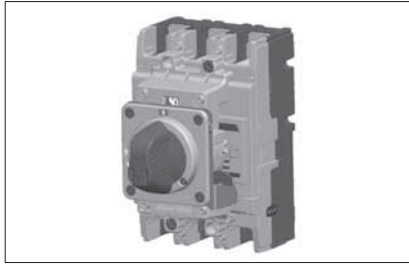

Mounting instructions

The external operating handle has not been mounted on the breakers.

For details on how to mount the handle, see the Operating Instructions packaged with the product.

[1] Mounting of external operating handle assembly

- Make sure that the breaker is in the OFF position.
 - Put the external operating handle assembly onto the breaker in place so that the breaker handle is engaged with the handle catch of the assembly.
- Rotate two knobs to secure the handle assembly.

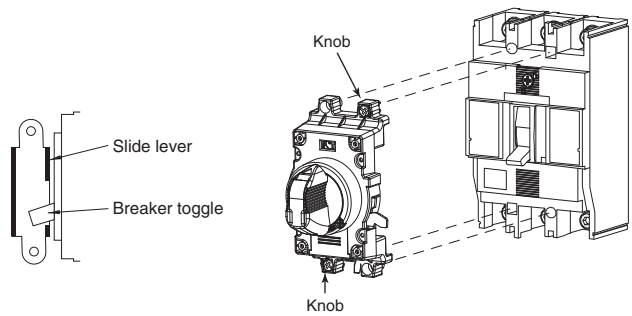

[2] Installation of handle escutcheon and latch plate

- Drill holes in the panel according to the panel cutout dimensions.
- Sandwich the panel between the handle escutcheon and latch plate and temporarily tighten using the supplied screws.
- Close the panel.
- Make adjustment so that the gap between the handle assembly and handle escutcheon is even and the assembly is not inclined against the breaker.

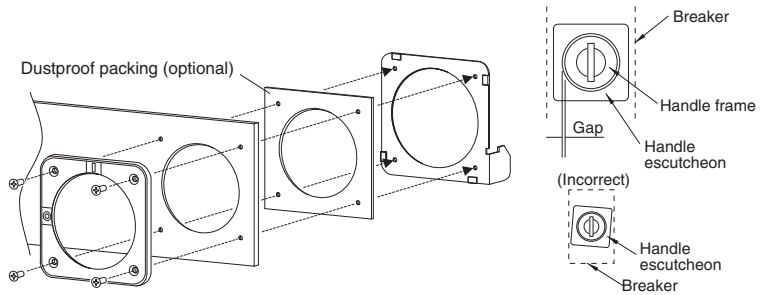

Breaker mounting direction

The ON and OFF positions of the handle and the positions of drilled holes in the panel do not need to be changed depending on the breaker mounting direction. The upper power supply type is standard. If a non-standard type is required, state the type when ordering.

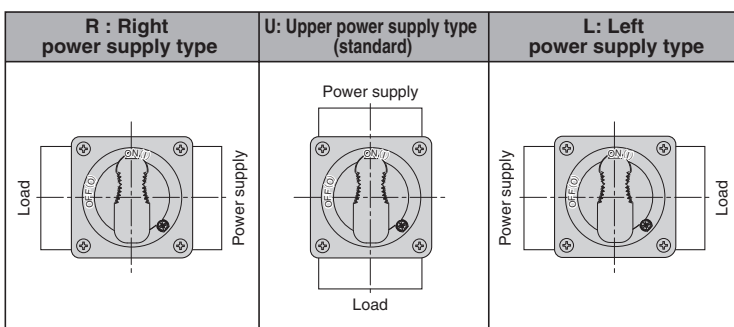

- For a change in mounting direction, see the Operating Instructions packaged with the product.

■ Panel lock mechanism

The external operating handle keeps the panel door locked when in the 'ON' position. There are two types, RESET Open and OFF Open.

(1) Reset Open (Standard type)

The handle is turned to the RESET OPEN position to open the panel door.

(2) OFF Open

The handle is turned to the OFF position to open the panel door.

● Panel lock release knob

The release knob enables the panel door to be opened with the handle in the 'ON' position. To release: turn the release knob in the direction of anti-clockwise with a flat-bladed screwdriver.

● Safety interlock (Standard)

The safety interlock prevents the breaker from turning ON as long as the panel is open. This interlock can be released using the hook lever.

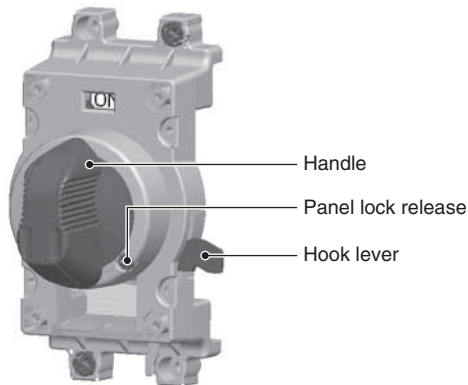

■ Toggle lock mechanism

● Padlock (Standard)

This mechanism allows the breaker to be padlocked in the ON or OFF position.

Padlocks are not supplied.

Up to three padlocks can be installed.



Padlock dimensions (mm)

Type of handle	A	Dia.
T2HB	13 min	ø5.5-8

※ : Padlocking in OFF position only required by IEC 60204-1 is also available.

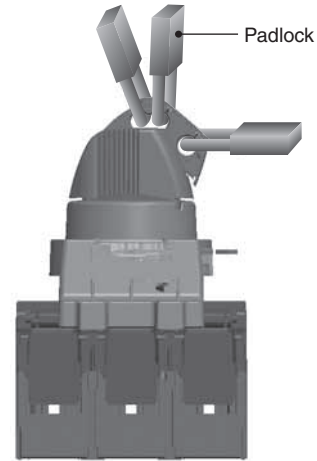

■ Protection degree IEC 60529

IP30	standard specification
IP50	optional, with a dust proof packing
IP55	special specification

■ To be stated when ordering

Order code T2HB16L U R 3 B T

Type of external operating handle	Breaker mounting direction	Panel lock	Protection degree	Colour	Padlock
T2HB16L T2HB25L	U: Upper power supply type * R: Right power supply type L: Left power supply type	R: RESET open * F: OFF open	3 : IP30 * 5 : IP50 S : IP55 (special spec.)	B : Black handle (Light gray base) * R : Red handle (Yellow base)	T : Lock in ON or OFF* N : Lock in OFF

*: standard specification

Externally mounted accessories

2. External operating handles

T2HB16L

Applicable breaker types

S160-SD, S160-GD, S160-SDN,
PVE160-SDL

HL: Handle Frame Centre Line
CL: Handle Centre Line

• Outline dimensions

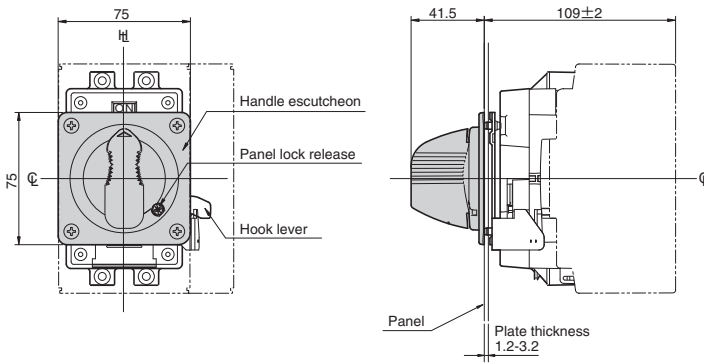

• Panel cutout dimensions

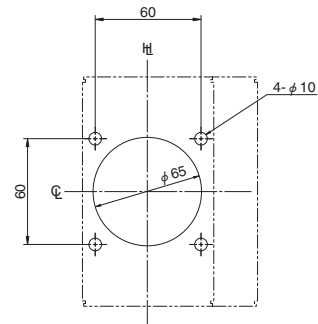

• Positions of the hinge and handle as seen from the load side of the breaker. Ensure that the hinge is positioned in the area.

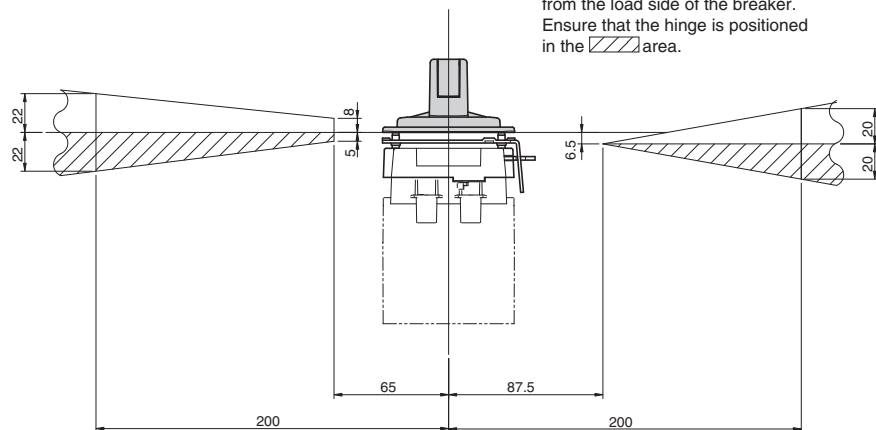

T2HB25L

Applicable breaker types

S250-SD, S250-GD, S250-SDN,
 PVS160-SDL, PVS250-SDL,
 PVS160-SNL, PVS250-SNL,
 PVS160-SDH, PVS250-SDH,
 PVS160-SNH, PVS250-SNH,
 PVS160-GDH, PVS250-GDH

HL: Handle Frame Centre Line
 CL: Handle Centre Line

• Outline dimensions

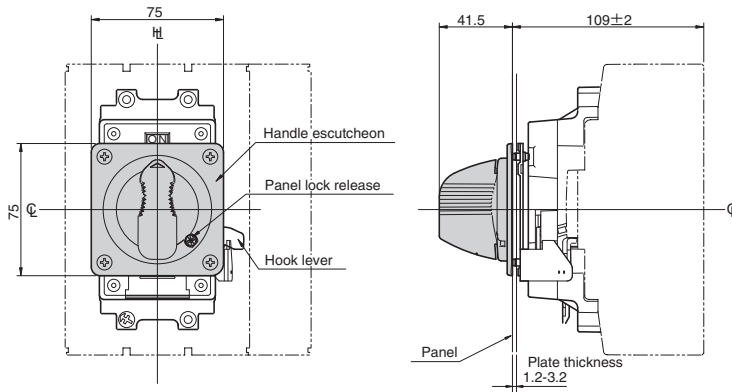

• Panel cutout dimensions

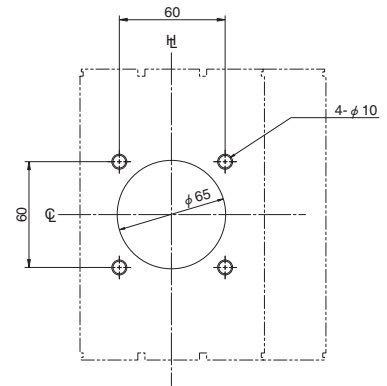

• Positions of the hinge and handle as seen from the load side of the breaker. Ensure that the hinge is positioned in the area.

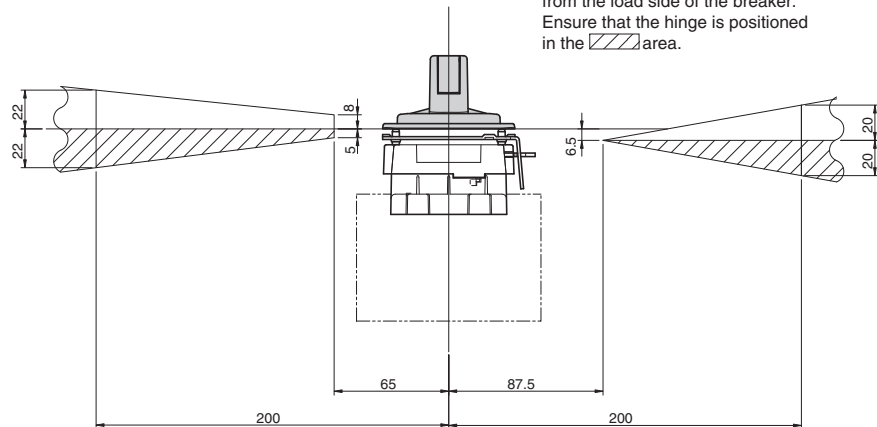

Externally mounted accessories

2. External operating handles

(2) Breaker-mounted (field installable small type) (HB)

The external operating handle is a tool that allows the breaker installed in a switchboard to be operated from outside and complies with IEC 60204-1.

The breaker-mounted type external operating handle is designed to be mounted directly to the breaker body.

Outer view

Types
T2HB40
T2HB80



Mounting instructions

The external operating handle has not been mounted on the breakers.

For details on how to mount the handle, see the Operating Instructions packaged with the product.

[1] Mounting of external operating handle assembly

- Make sure that the breaker is in the OFF position.
- Put the external operating handle assembly onto the breaker in place so that the breaker handle is engaged with the handle catch of the assembly.
Rotate two knobs to secure the handle assembly.
- For T2HB40 and T2HB80, tighten the bolts to secure the handle assembly.

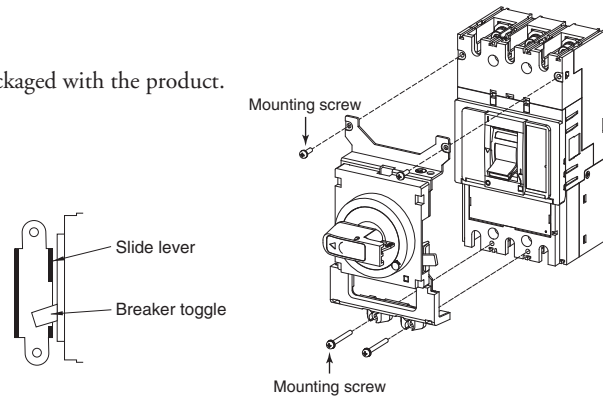

[2] Installation of handle escutcheon and latch plate

- Drill holes in the panel according to the panel cutout dimensions.
Sandwich the panel between the handle escutcheon and latch plate and temporarily tighten using the supplied screws.
- Close the panel.
Make adjustment so that the gap between the handle assembly and handle escutcheon is even and the assembly is not inclined against the breaker.

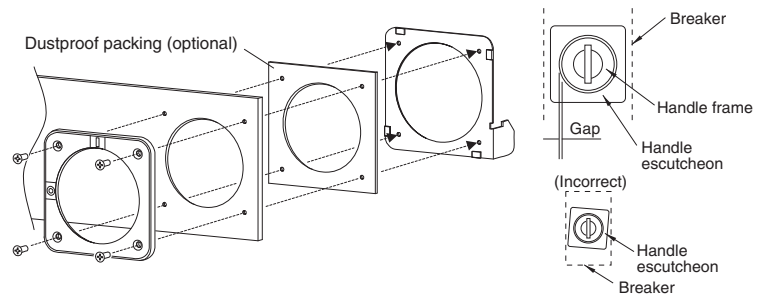

Breaker mounting direction

The ON and OFF positions of the handle and the positions of drilled holes in the panel do not need to be changed depending on the breaker mounting direction. The upper power supply type is standard. If a non-standard type is required, state the type when ordering.

R : Right power supply type	U: Upper power supply type (standard)	L: Left power supply type

- For a change in mounting direction, see the Operating Instructions packaged with the product.

■ Panel lock mechanism

The external operating handle keeps the panel door locked when in the 'ON' position. There are two types, RESET Open and OFF Open.

(1) Reset Open (Standard type)

The handle is turned to the RESET OPEN position to open the panel door.

(2) OFF Open

The handle is turned to the OFF position to open the panel door.

● Panel lock release knob (Standard)

The release knob enables the panel door to be opened with the handle in the 'ON' position. To release: turn the release knob in the direction of anti-clockwise with a flat-bladed screwdriver.

● Safety interlock (Standard)

The safety interlock prevents the breaker from turning ON as long as the panel is open. This interlock can be released using the hook lever.

■ Toggle lock mechanism

● Padlock (Standard)

This mechanism allows the breaker to be padlocked in the ON or OFF position.

Padlocks are not supplied.

Up to three padlocks can be installed.



Padlock dimensions (mm)

Type of handle	A	Dia.
T2HB	13 min	ø5.5-8

● Key lock (Optional)

Key locking is possible in the ON or OFF position.

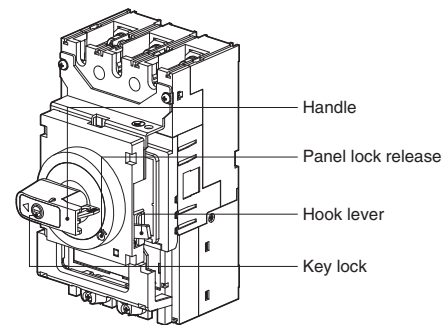

※ : Padlocking in OFF position only required by IEC 60204-1 is also available.

Please specify when ordering.

■ Protection degree IEC 60529

IP30	standard specification
IP50	optional, with a dust proof packing
IP55	special specification

■ To be stated when ordering

Order code T2HB40 U R 3 B T

Type of external operating handle	Breaker mounting direction	Panel lock	Protection degree	Colour	Key lock / Padlock
T2HB40 T2HB80	U: Upper power supply type * R: Right power supply type L: Left power supply type	R: RESET open * F: OFF open	3 : IP30 * 5 : IP50 S : IP55 (special spec.)	B : Black handle (Light gray base) * R : Red handle (Yellow base)	T : with padlock (Lock in ON or OFF) * W : with key lock and padlock (Lock in ON or OFF) N : with padlock (lock in OFF) K : with key lock and padlock (lock in OFF)

*: standard specification

Externally mounted accessories

2. External operating handles

■ Outline dimensions

T2HB40

Applicable breaker types	A (mm)	B (mm)
S400-ND, PVS400-NDL, PVS400-NNL, PVS400-NDH, PVS400-NNH	150 ± 2	97

ASL: Arrangement Standard Line

HL: Handle Frame Centre Line

CL: Handle Centre Line

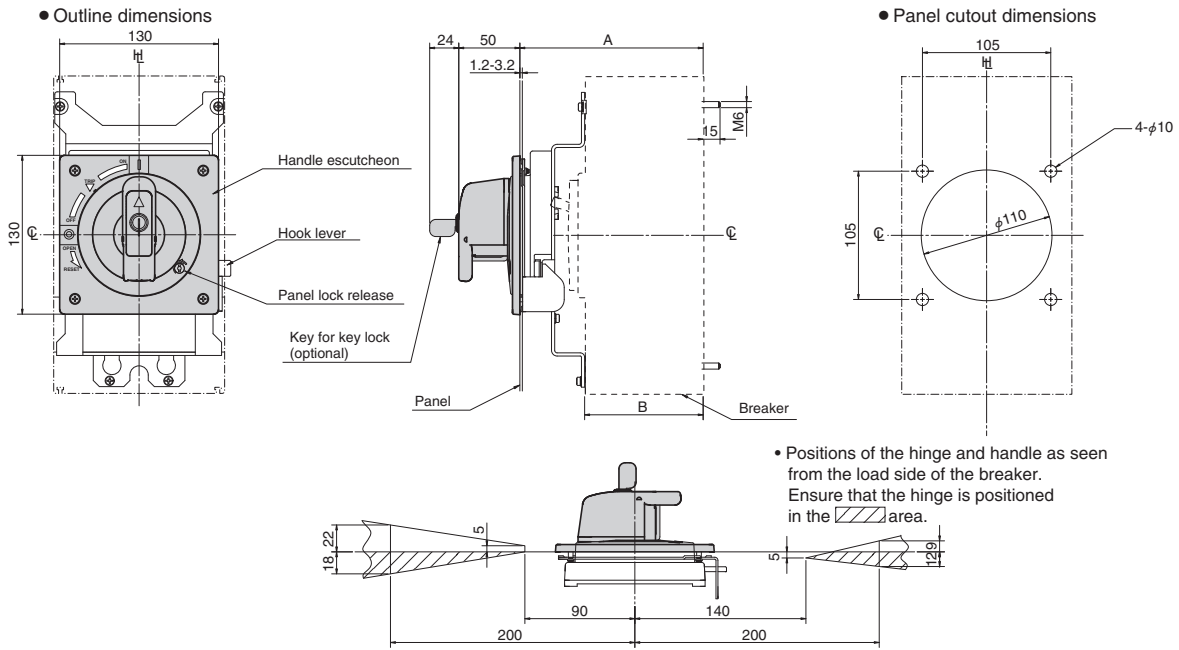

T2HB80

Applicable breaker types	A (mm)
S800-ND, S1000-ND, PVS800-NDL, PVS800-NNL, PVS800-NDH PVS800-GDH, PVS800-NNH	150 ± 2

ASL: Arrangement Standard Line
 H: Handle Frame Centre Line
 C: Handle Centre Line

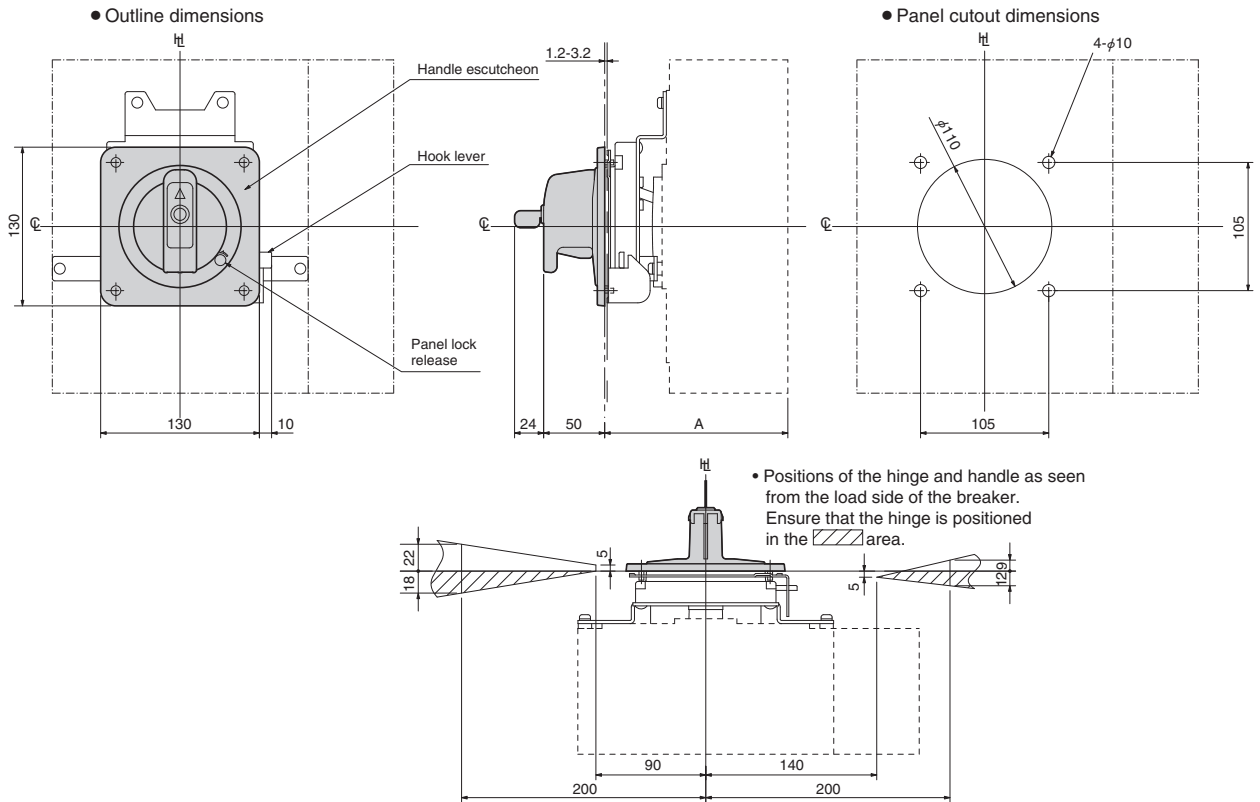

Externally mounted accessories

2. External operating handles

(3) Door-mounted (depth adjustable) (HP)

Door-mounted type external operating handles allow breakers installed in control centers or switchboards to be manually operated from outside and complies with IEC 60204-1.

This handle assembly consists of an operation mechanism section which is to be installed in the breaker body, a handle section which is to be installed in a panel and a square shaft which couples both the sections.

■ Outer view

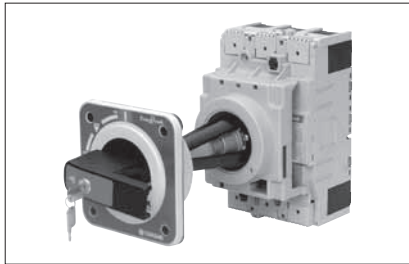

■ Operation direction of handles

Rotate the operating handle clockwise to turn the breaker on.

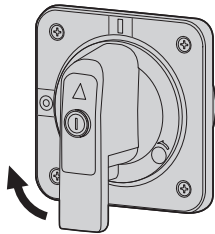

Rotate clockwise
to turn the breaker ON

■ Breaker mounting direction

The ON and OFF positions of the handle and the positions of drilled holes in the panel do not need to be changed depending on the breaker mounting direction.

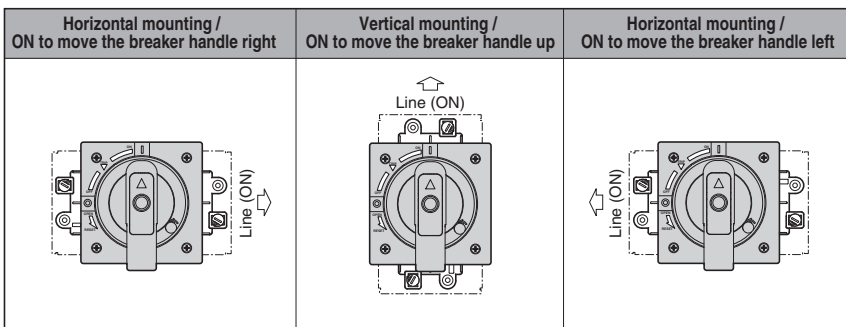

■ Panel lock mechanism

The external operating handle keeps the panel door locked when in the 'ON' position. There are two types, RESET Open and OFF Open.

(1) Reset Open (Standard type)

The handle is turned to the RESET OPEN position to open the panel door.

(2) OFF Open

The handle is turned to the OFF position to open the panel door.

● Panel lock release knob (standard specification)

The release knob enables the panel door to be opened with the handle in the 'ON' position. To release: turn the release knob in the direction of anti-clockwise with a flat-bladed screwdriver.

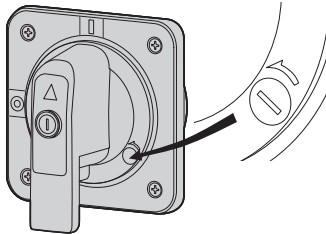

■ Protection degree IEC 60529

IP54	standard specification
IP65	special specification

■ Toggle lock mechanism

● Padlock (Standard)

This mechanism allows the breaker to be padlocked in the ON or OFF position.

Padlocks are not supplied.

Up to three padlocks can be installed.



Padlock dimensions (mm)

Type of handle	A	Dia.
T2HP	13 min	ø5,5-8

● Key lock (Optional)

Key locking is possible in the ON or OFF position.

※ : Padlocking in OFF position only required by IEC 60204-1 is also available.

Please specify when ordering.

■ Dimensions of square shafts available

There are the following shaft dimensions available. Select an appropriate shaft depending on the mounting position of the breaker. Cut the shaft to an appropriate length if required. Coat the cut end faces of the shaft with an anti-corrosion paint.

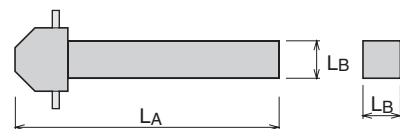

Shafts order codes	LA (mm)	LB (mm)
T2PS251	121	
T2PS252	221	8
T2PS253	321	
T2PS254	421	
T2PS401	147.5	
T2PS402	247.5	14
T2PS403	347.5	
T2PS404	447.5	

■ To be stated when ordering

Order code T2HP25L R 5 B T

Type of external operating handle	Panel lock	Protection degree	Colour	Key lock / Padlock
T2HP16L T2HP40 T2HP25L T2HP80 T1HPX6	R : RESET open * F : OFF open	5 : IP54 * 6 : IP65	B : Black handle (Light gray base) * R : Red handle (Yellow base)	T : with padlock (Lock in ON or OFF) W : with key lock and padlock (Lock in ON or OFF) N : with padlock (lock in OFF) * K : with key lock and padlock (lock in OFF)

*: standard specification

Externally mounted accessories

2. External operating handles

HL: Handle Frame Centre Line
 CL: Handle Centre Line

Outline dimensions

T2HP16L

Outline dimensions

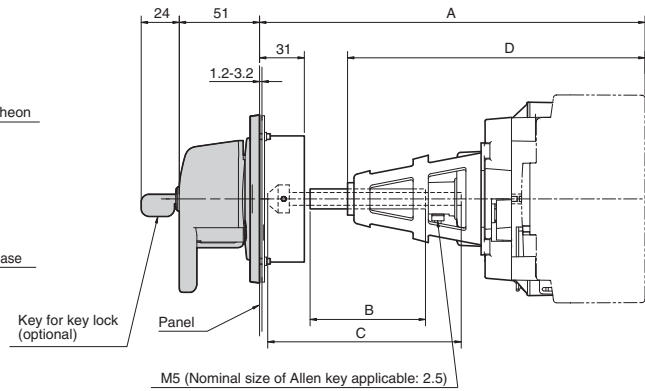
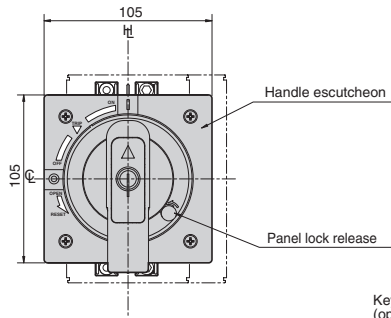

Panel cutout dimensions

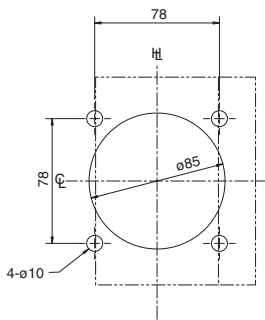

• Positions of the hinge and handle as seen from the load side of the breaker. Ensure that the hinge is positioned in the hatched area.

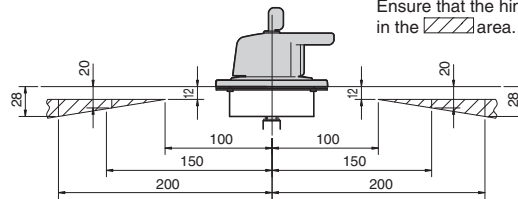

Applicable breaker types	A ①	B	C	D	Square shaft applicable	Shaft support
S160-SD, S160-GD, S160-SDN, PVE160-SDL	229 min.	56	107	186	T2PS251	Yes
	243 max.	70	121	186		Yes
	343 max.	170	221	186	T2PS252	Yes
	443 max.	270	321	186	T2PS253	Yes
	543 max.	370	421	186	T2PS254	

Note ①:

"Min (minimum)" means the minimum possible distance from the panel surface to the breaker mounting surface, which can be formed by cutting the square shaft.
 "Max (maximum)" means the maximum distance of the same section, which is formed with no cutting of the square shaft.

- A: Distance from the panel surface to the breaker mounting surface
- B: Length of the tube used to cover the square shaft
- C: Length of the square shaft used
- D: Distance from the tip of the shaft support to the breaker mounting surface

⊥ : Handle Frame Centre Line
 ⊕ : Handle Centre Line

■ Outline dimensions

T2HP25L

● Outline dimensions

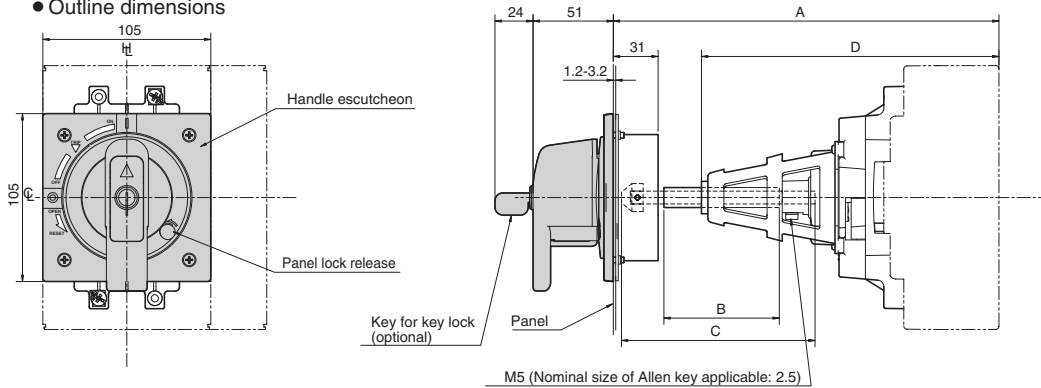

● Panel cutout dimensions

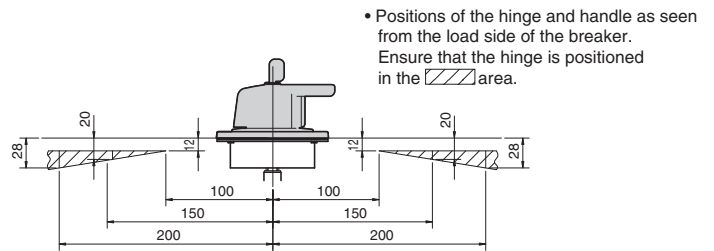
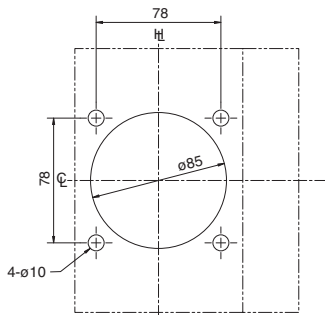

Applicable breaker types	A ①	B	C	D	Square shaft applicable	Shaft support
S250-SD, S250-GD, S250-SDN, PVS160-SDL, PVS250-SDL, PVS160-SNL, PVS250-SNL, PVS160-SDH, PVS250-SDH, PVS160-SNH, PVS250-SNH, PVS160-GDH, PVS250-GDH	229 min.	56	107	186	T2PS251	Yes
	243 max.	70	121	186		Yes
	343 max.	170	221	186	T2PS252	Yes
	443 max.	270	321	186	T2PS253	Yes
543 max.	370	421	186	T2PS254		

Note ①:

"Min (minimum)" means the minimum possible distance from the panel surface to the breaker mounting surface, which can be formed by cutting the square shaft.
 "Max (maximum)" means the maximum distance of the same section, which is formed with no cutting of the square shaft.

- A: Distance from the panel surface to the breaker mounting surface
- B: Length of the tube used to cover the square shaft
- C: Length of the square shaft used
- D: Distance from the tip of the shaft support to the breaker mounting surface

Externally mounted accessories

2. External operating handles

ASL: Arrangement Standard Line
 HL: Handle Frame Centre Line
 CL: Handle Centre Line

Outline dimensions

T2HP40

Outline dimensions

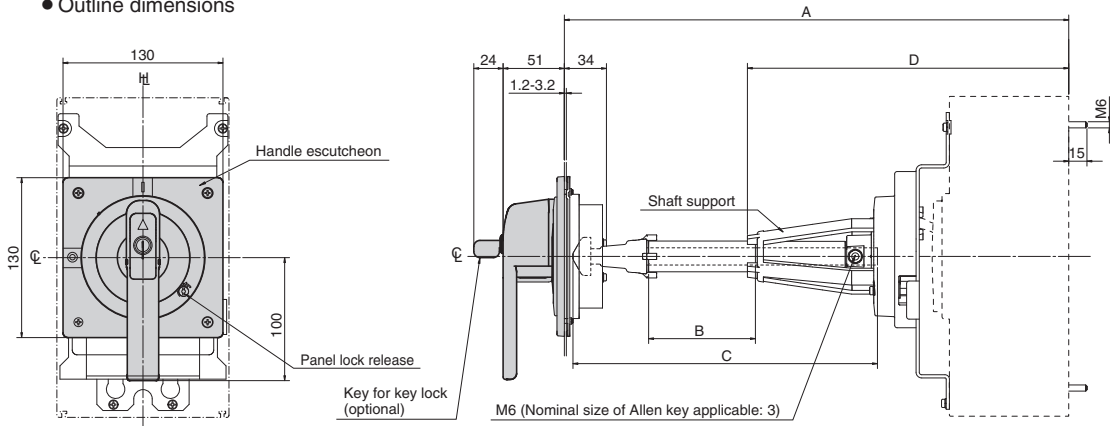

Panel cutout dimensions

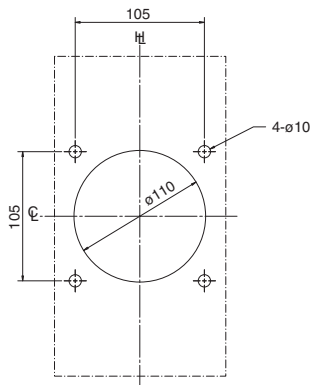

• Positions of the hinge and handle as seen from the load side of the breaker. Ensure that the hinge is positioned in the hatched area.

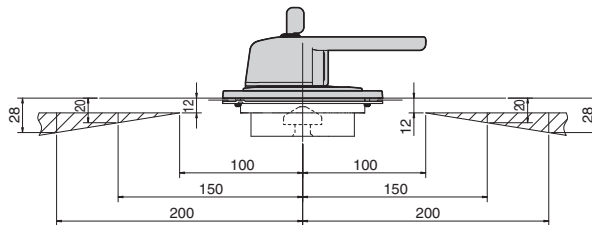

Applicable breaker types	A ①	B	C	D	Square shaft applicable	Shaft support
S400-ND, PVS400-NDL, PVS400-NNL, PVS400-NDH, PVS400-NNH	270 min.	12	107.5	—	T2PS401	Non
	310 max. ②	52	147.5	—		
	340 min. ②	10	177.5	261	T2PS402	Yes
	410 max.	80	247.5	261		
	510 max.	180	347.5	261		
610 max.	280	447.5	261	T2PS404		

Notes:

- ① "Min (minimum)" means the minimum possible distance from the panel surface to the breaker mounting surface, which can be formed by cutting the square shaft. "Max (maximum)" means the maximum distance of the same section, which is formed with no cutting of the square shaft.
- ② When dimension A is in a range of 310 mm to 340 mm, cut square shaft T2PS402 to an appropriate length and use the shaft without shaft support.

- A: Distance from the panel surface to the breaker mounting surface
 B: Length of the tube used to cover the square shaft
 C: Length of the square shaft used
 D: Distance from the tip of the shaft support to the breaker mounting surface

ASL: Arrangement Standard Line
 H: Handle Frame Centre Line
 C: Handle Centre Line

■ Outline dimensions

T2HP80

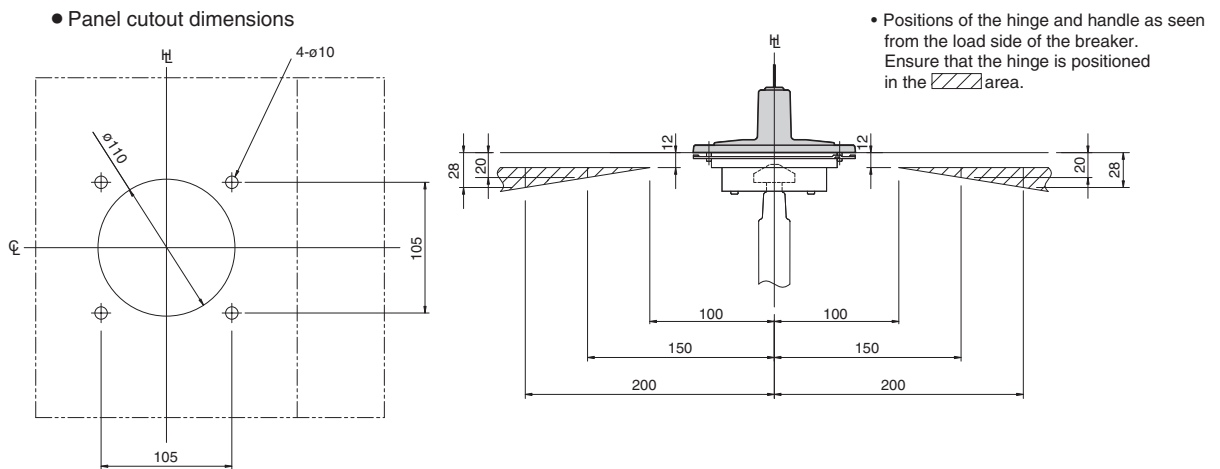
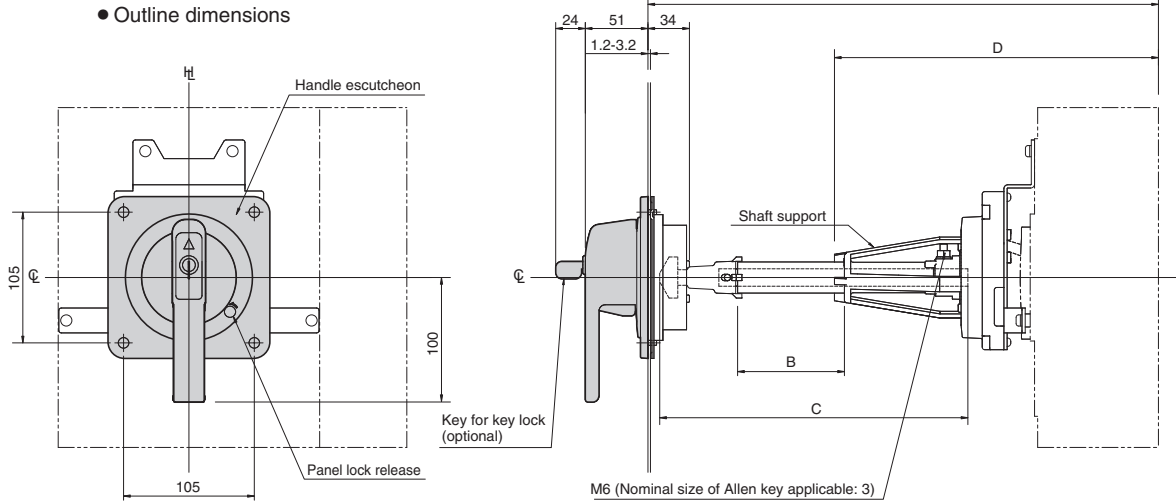

Applicable breaker types	A ①	B	C	D	Square shaft applicable	Shaft support
S800-ND, S1000-ND, PVS800-NDL, PVS800-NNL, PVS800-NDH, PVS800-GDH PVS800-NNH	270 min.	12	107.5	—	T2PS401	Non
	310 max.②	52	147.5	—		
	340 min.②	10	177.5	261	T2PS402	Yes
	410 max.	80	247.5	261		
510 max.	180	347.5	261	T2PS403		
	610 max.	280	447.5	261	T2PS404	

Notes:

- ①. "Min (minimum)" means the minimum possible distance from the panel surface to the breaker mounting surface, which can be formed by cutting the square shaft. "Max (maximum)" means the maximum distance of the same section, which is formed with no cutting of the square shaft.
- ②. When dimension A is in a range of 310 mm to 340 mm, cut square shaft T2PS402 to an appropriate length and use the shaft without shaft support.

- A: Distance from the panel surface to the breaker mounting surface
 B: Length of the tube used to cover the square shaft
 C: Length of the square shaft used
 D: Distance from the tip of the shaft support to the breaker mounting surface

Externally mounted accessories

2. External operating handles

ASL: Arrangement Standard Line
 HL: Handle Frame Centre Line
 CL: Handle Centre Line

Outline dimensions

T1HPX6

Outline dimensions

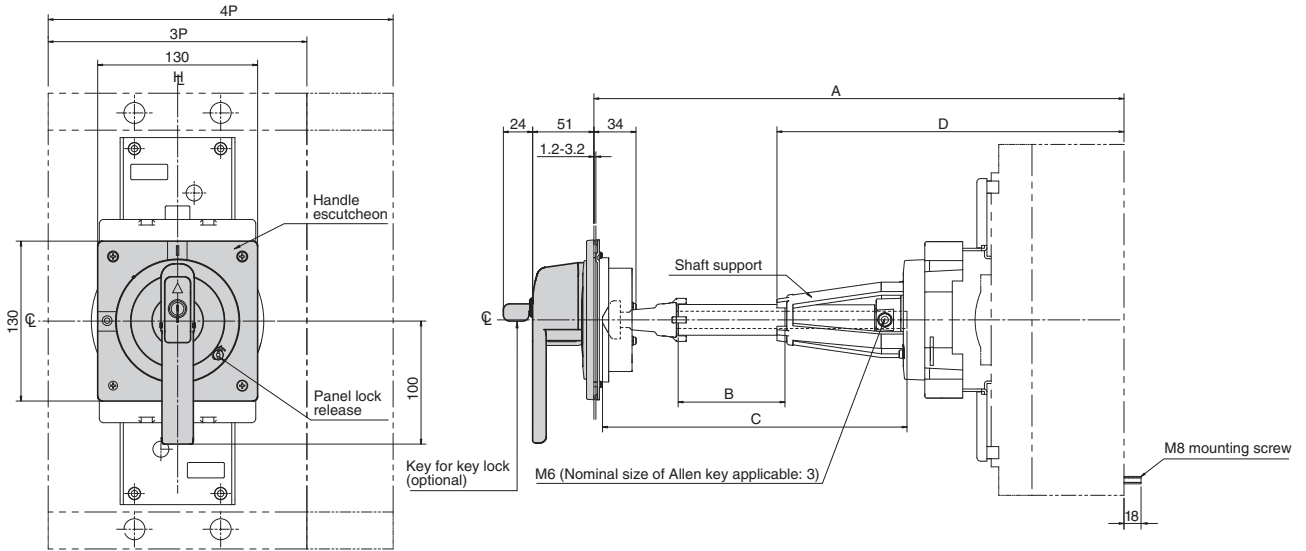

Panel cutout dimensions

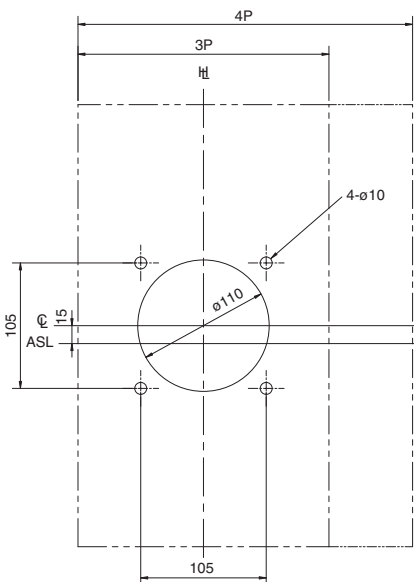

• Positions of the hinge and handle as seen from the load side of the breaker. Ensure that the hinge is positioned in the hatched area.

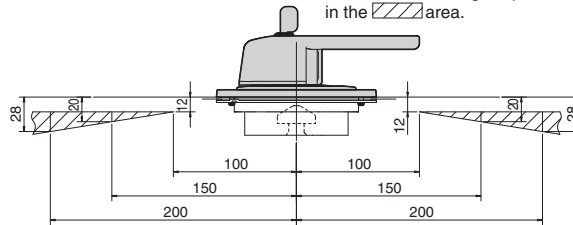

Applicable breaker types	A ①	B	C	D	Square shaft applicable	Shaft support
XS1250ND, XS1600ND	387min.	52	147.5	337	T2PS401	Non
	487max.	80	247.5	337	T2PS402	
	587max.	180	347.5	337	T2PS403	
	687max.	280	447.5	337	T2PS404	

Note ①:

"Min (minimum)" means the minimum possible distance from the panel surface to the breaker mounting surface, which can be formed by cutting the square shaft.
 "Max (maximum)" means the maximum distance of the same section, which is formed with no cutting of the square shaft.

A: Distance from the panel surface to the breaker mounting surface
 C: Length of the square shaft used

B: Length of the tube used to cover the square shaft
 D: Distance from the tip of the shaft support to the breaker mounting surface

3. Toggle holder (HH) and toggle lock (HL)

Toggle holder (HH)

Simply fitting the toggle holder onto the breaker toggle disables breaker operation without using padlocks.

Toggle lock (HL)

The toggle lock is a tool that locks the breaker on or off. When an overcurrent occurs, the breaker will trip even if the breaker toggle is locked in the ON position. (Use commercially available padlocks).

Toggle holders/toggle locks

Type of breaker	Toggle holder		Figure	Toggle lock		Figure
	Order codes	Marking codes		Order codes	Marking codes	
S160-SD, S160-GD, S160-SDN, PVE160-SDL	T2HH25L	T2HH25L	4	T2HL25L	T2HL25L	1
S250-SD, S250-GD, S250-SDN, PVS160-SDL, PVS250-SDL, PVS160-SNL, PVS250-SNL, PVS160-SDH, PVS250-SDH, PVS160-SNH, PVS250-SNH, PVS160-GDH, PVS250-GDH	T2HH25L	T2HH25L	4	T2HL25L	T2HL25L	1
S400-ND, PVS400-NDL, PVS400-NNL, PVS400-NDH, PVS400-NNH, S800-ND, S1000-ND, PVS800-NDL, PVS800-NNL, PVS800-NDH, PVS800-GDH, PVS800-NNH	T2HL40 ①	T2HL40	2	T2HL40	T2HL40	2
XS1250ND, XS1600ND	XKC9	XKC9	3 (ℓ =86)	XKC9	XKC9	3 (ℓ =86)
XS2000ND, XS2500ND, XS3200ND	XKC10	XKC10	3 (ℓ =94)	XKC10	XKC10	3 (ℓ =94)

Notes: ①. Same as toggle lock.

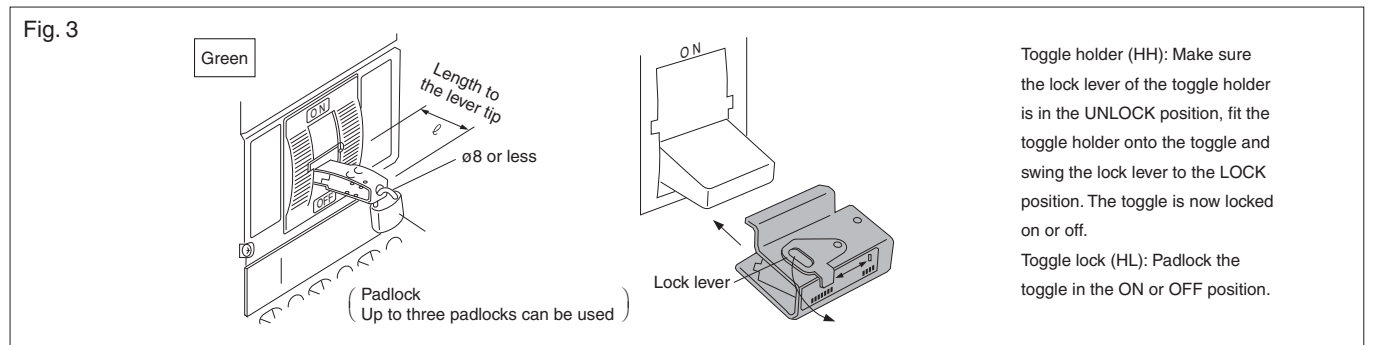
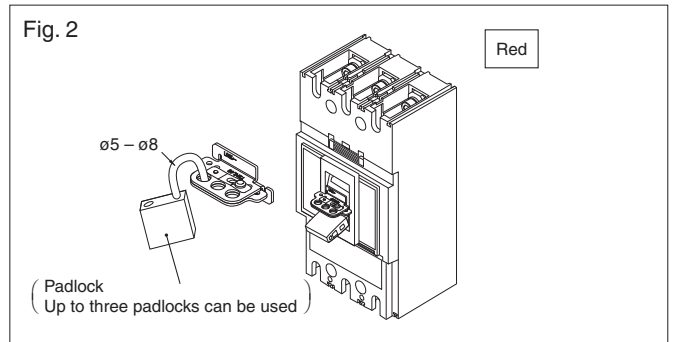
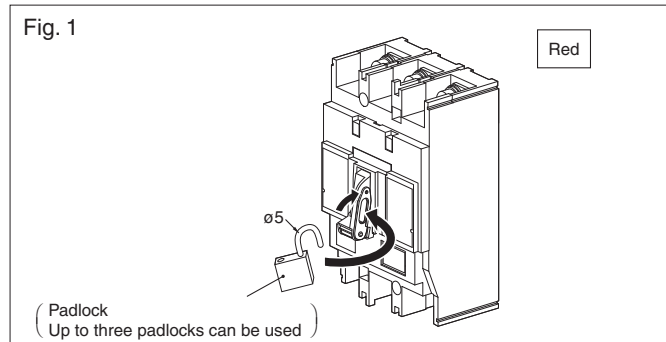

Toggle holder (HH): Make sure the lock lever of the toggle holder is in the UNLOCK position, fit the toggle holder onto the toggle and swing the lock lever to the LOCK position. The toggle is now locked on or off.
Toggle lock (HL): Padlock the toggle in the ON or OFF position.

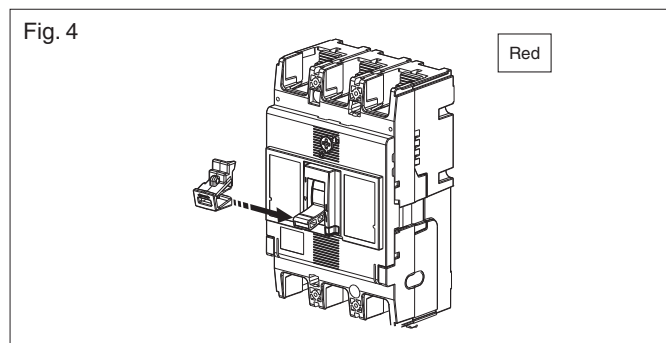

Externally mounted accessories

4. Terminal covers

The terminal covers supplied with the DC MCCB (250AF or less) must be used for MCCB installation.

There are two types of terminal covers and options CF for front-connected breakers, CR for rear-connected and plug-in breakers.

(1) CF for front-connected breakers

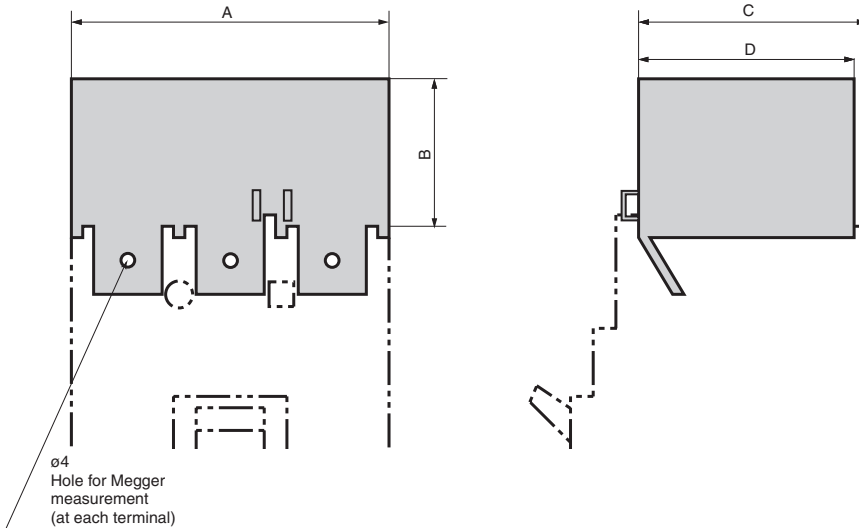

Plug-in mounted version

This version can be mounted simply by being plugged in the breaker body.

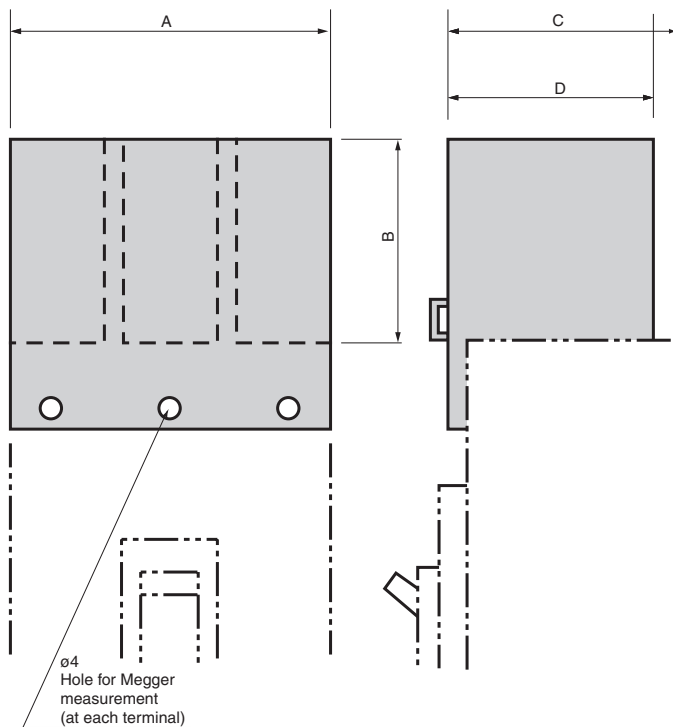

Screw-mounted version

The terminal covers are mounted to the breakers using tapping screws.

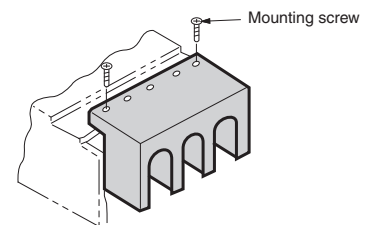

- To be stated when ordering
- Please state the order codes on the next page.

Types and dimensions of terminal covers, units in mm

CF for front-connected breakers

Types of breakers	Terminal cover				A		B		C ②		D ②		Colour of cover G:Gray	Mounting version	
	Size	Note:	Order codes ①	Marking codes	3 poles	4 poles	3 poles	4 poles	3 poles	4 poles	3 poles	4 poles		Plug-in mounted	Screw-mounted
S160-SD, S160-GD, S160-SDN, PVE160-SDL	Large		T2CF 12L * SLNG	—	75	—	50	—	61	—	60.3	—	G	○	—
S250-SD, S250-GD, S250-SDN, PVS160-SDL, PVS250-SDL, PVS160-SNL, PVS250-SNL, PVS160-SDH, PVS250-SDH, PVS160-SNH, PVS250-SNH, PVS160-GDH, PVS250-GDH	Large	③	T2CF 25L * SLNG	T2CF25L * SL	105	140	55	55	59	59	57.5	57.5	G	○	—
S400-ND, PVS400-NDL, PVS400-NDH, PVS400-NNH	Large	④	T2CF40 * SWNG	T2CF40 * SW	180	240	110	114	97	98	96	98	G	○	—
	Large	⑤	T2CF40 * SLNG	T2CF40 * SL	140	185	85	85	97	97	94.5	94.5	G	○	—
S800-ND, S1000-ND, PVS800-NDL, PVS800-NDH, PVS800-NNH	Large		T2CF80 * SLNG	TPR-5BA	215	285	130	130	99.5 (102)	99.5 (102)	99 (101.5)	99 (101.5)	G	—	○

Notes:

- ①. The asterisk indicates the number of poles. Please state the number of poles at the asterisk position when ordering.
- ②. Values in parentheses indicate the distance to the head of terminal cover mounting screws.
- ③. The connection wire size must use less than 100mm². The connection wire size 150mm² or more not available.
- ④. Applicable to 3-pole breakers with spread extension bars.
- ⑤. Applicable to the breakers without extension bars.

Externally mounted accessories

4. Terminal covers

(2) CR for rAear-connected and plug-in breakers

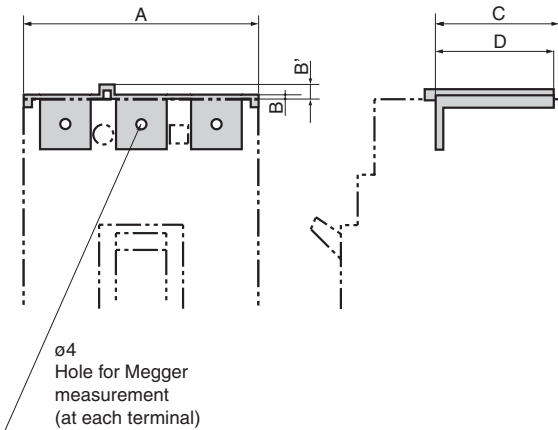

Fig.1

Plug-in mounted version

This version can be mounted simply by being plugged in the breaker body.

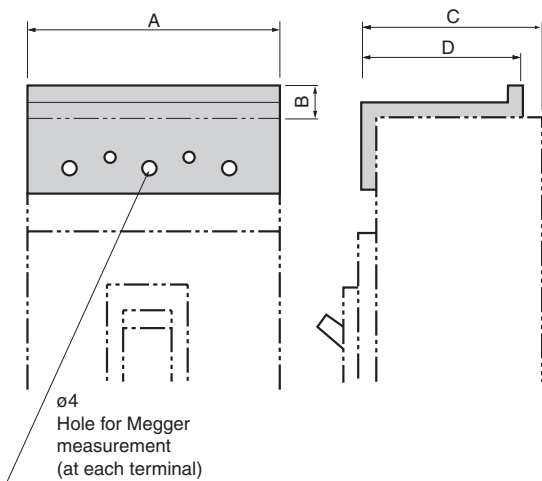
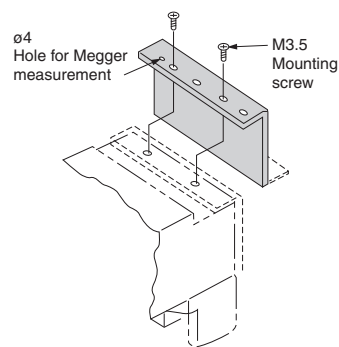

Fig.2



Screw-mounted version

The terminal covers are mounted to the breakers using tapping screws.

- To be stated when ordering
- Please state the order codes on the next page if ordering separately from the breaker.

Types and dimensions of terminal covers, units in mm

Types of breakers	Order codes ①	Marking codes	A		B		B'	C ②		D ②		Colour of cover B: Black G: Gray	Mounting version		
			3 poles	4 poles	3 poles	4 poles		3 poles	4 poles	3 poles	4 poles		Plug-in mounted	Screw-mounted	Fig.
S160-SD, S160-GD, S160-SDN, PVE160-SDL	T2CR12L * SG	—	75	100	5.3	5.3	—	61	61	60.3	60.3	G	○	—	1
S250-SD, S250-GD, S250-SDN, PVS160-SDL, PVS250-SDL, PVS160-SNL, PVS250-SNL, PVS160-SDH, PVS250-SDH, PVS160-SNH, PVS250-SNH, PVS160-GDH, PVS250-GDH	T2CR25L * SG	—	105	140	2.3	2.3	5.3	58.6	58.6	57.1	57.1	G	○	—	1
S400-ND, PVS400-NDL, PVS400-NNL, PVS400-NDH, PVS400-NNH	T2CR40 * SG	T2CR40 * S	140	185	3	3	5	97	97	93	93	G	○	—	1
S800-ND, S1000-ND, PVS800-NDL, PVS800-NNL, PVS800-NDH PVS800-GDH, PVS800-NNH	T2CR80 * SG	XPS6	206	280	15	18	—	101 (103.5)	99 (101.5)	100.5 (103)	98 (100.5)	G	—	○	2

Notes:

①. The asterisk indicates the number of poles. Please state the number of poles at the asterisk position when ordering.

One set includes one terminal cover for the ON side and one for the OFF side.

②. Values in parentheses indicate the distance to the head of terminal cover mounting screws.

Externally mounted accessories

5. Terminal blocks (TF)

18mm width 6 terminals

Vertical leading type (T2TF00L) with 100/125A frame MCCB

Mounting position/typical terminal arrangement

Dimensions, mm

Frame size (A)	Types of breakers	A
100, 125	S160-SD, S160-GD, S160-SDN, PVE160-SDL	9

Notes:

- 1) Tightening torque of M3.5 terminal screws: 0.9 – 1.2 N • m
- 2) Applicable wire size: 2.0mm² max

Combination of terminal arrangement

AX	AL	SH	UV	Left terminal	Right terminal
1C	1C	1	—	Ex.2	Ex.4
1C	1C	—	1	Ex.2	Ex.5
1C	2C	—	—	Ex.2	Ex.3
2C	—	1	—	Ex.1	Ex.4
2C	—	—	1	Ex.1	Ex.5
2C	2C	—	—	Ex.2	Ex.3
3C	1C	—	—	Ex.2	Ex.1
4C	—	—	—	Ex.1	Ex.2

AX, AL takes precedence left terminal connection.
AL is connected to the left terminal in preference to the AX.
Contact TERASAKI for the combination other than the above.

18mm width 6 terminals

Vertical leading type (T2TF00L) with 125/225/250A frame MCCB

Mounting position/typical terminal arrangement

Dimensions, mm

Frame size (A)	Types of breakers	A
125, 225, 250	S250-SD, S250-GD, S250-SDN (3 poles) PVS160-SDL, PVS250-SDL (3 poles) PVS160-SDH, PVS250-SDH (4 poles) PVS160-SNL, PVS250-SNL (3/4 poles) PVS160-SNH, PVS250-SNH (4 poles) PVS160-GDH, PVS250-GDH (4 poles)	7

Notes:

- 1) Tightening torque of M3.5 terminal screws: 0.9 – 1.2 N • m
- 2) Applicable wire size: 2.0mm² max

Combination of terminal arrangement

AX	AL	SH	UV	Left terminal	Right terminal
1C	1C	1	—	Ex.2	Ex.6
1C	1C	—	1	Ex.2	Ex.7
2C	—	1	—	Ex.1	Ex.6
2C	—	—	1	Ex.1	Ex.7
2C	2C	—	—	Ex.2	Ex.3
2C	1C	1	—	Ex.2	Ex.8
2C	1C	—	1	Ex.2	Ex.9
3C	1C	—	—	Ex.2	Ex.1
3C	2C	—	—	Ex.3	Ex.4
4C	—	—	—	Ex.1	Ex.2
4C	2C	—	—	Ex.3	Ex.5

AX, AL takes precedence left terminal connection.
AL is connected to the left terminal in preference to the AX.
1 row terminal block is used in preference to 2 rows the terminal blocks.
Contact TERASAKI for the combination other than the above.

18mm width 6 terminals
Vertical leading type (T2TFX0) with 400A frame MCCB

Mounting position/typical terminal arrangement

Dimensions, mm

Frame size (A)	Types of breakers				
	MCCB				
	A	B	C	D	
400	S400-ND (3 poles) PVS400-NDL (3/4 poles) PVS400-NDH (4 poles) PVS400-NNL (3 poles) PVS400-NNL, PVS400-NNH (4 poles)	33	51.5	63.5	75.5

Notes:
 1) Tightening torque of M3.5 terminal screws: 0.9 – 1.2 N • m
 2) Applicable wire size: 2.0mm² max

18mm width 6 terminals
Vertical leading type (T2TFX0) with 800/1000A frame MCCB

Mounting position/typical terminal arrangement

Dimensions, mm

Frame size (A)	Types of breakers				
	MCCB				
	A	B	C	D	
800, 1000	S800-ND, S1000-ND (3 poles) PVS800-NDL (3/4 poles) PVS800-NNL (3 poles) PVS800-NDH, PVS800-NNL (4 poles) PVS800-GDH, PVS800-NNH (4 poles)	33	51.5	63.5	75.5

Notes:
 1) Tightening torque of M3.5 terminal screws: 0.9 – 1.2 N • m
 2) Applicable wire size: 2.0mm² max

Externally mounted accessories

5. Terminal blocks (TF)

Horizontal leading type (LTF) with 1250 to 3200A frame MCCB

Mounting position/typical terminal arrangement

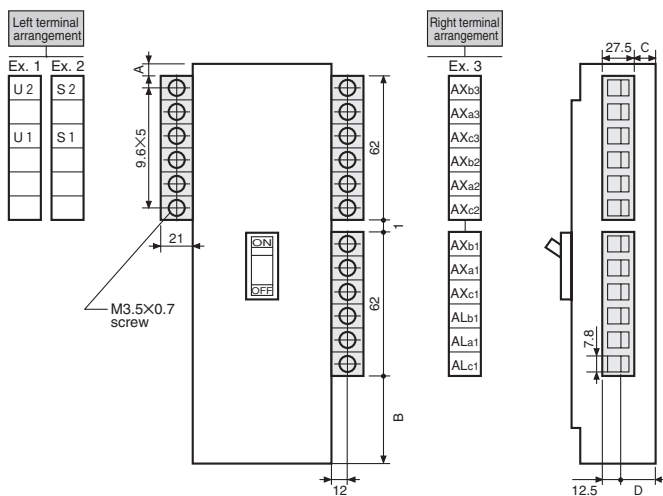

Dimensions, mm

Frame size (A)	Types of breakers	A	B	C	D
1250, 1600	XS1250ND, XS1600ND	51	194	77	92
2000	XS2000ND	54	208	100	115
2500	XS2500ND	54	208	100	115
3200	XS3200ND	54	208	100	115

Notes:

- 1) Values in parentheses applies to 4-pole breakers.
- 2) Tightening torque of M3.5 terminal screws: 0.9 – 1.2 N·m
- 3) Applicable wire size: 2.0mm² max x 2

6

Outline Dimensions

DC Air Circuit Breakers Outline Dimensions

AR208S, AR212S, AR216S, AR220S 3P	6-2
AR325S, AR332S 3P	6-4
AR325-NDH 4P	6-6
AR440S 3P	6-8

DC Moulded Case Circuit Breakers Outline Dimensions

S160-SD, S160-GD, S160-SDN, S250-SD, S250-GD, S250-SDN 3P	6-10
S400-ND 3P	6-11
S800-ND 3P	6-11
S1000-ND 2P, 3P	6-12
XS1250ND 2P, 3P	6-13
XS1600ND 2P, 3P	6-14
XS2000ND 2P, 3P	6-15
XS2500ND, XS3200ND 2P, 3P	6-16
PVE160-SDL 3P	6-17
PVS160-SDL, PVS250-SDL 3P	6-18
PVS250-SNL 3P	6-18
PVS160-SNL, PVS250-SNL 4P	6-19
PVS160-GDH, PVS250-GDH 4P	6-19
PVS160-SDH, PVS250-SDH, PVS160-SNH, PVS250-SNH 4P	6-20
PVS400-NDL 3P	6-21
PVS400-NDL, PVS400-NDH 4P	6-21
PVS400-NNL 3P	6-22
PVS400-NNL, PVS400-NNH 4P	6-22
PVS800-NDL 3P	6-23
PVS800-NDL, PVS800-NDH 4P	6-23
PVS800-NNL 3P	6-24
PVS800-NNL, PVS800-NNH 4P	6-24

DC Air Circuit Breakers

Outline dimensions (mm)

● Type AR208S 3P, AR212S 3P, AR216S 3P, AR220S 3P Draw-out type

Terminal size

Type	Ⓣ ₁	Ⓣ ₂	Ⓣ ₃	W
AR208S	10	10	15	17.5
AR212S	10	10	15	17.5
AR216S	20	15	25	22.5
AR220S	20	15	25	—

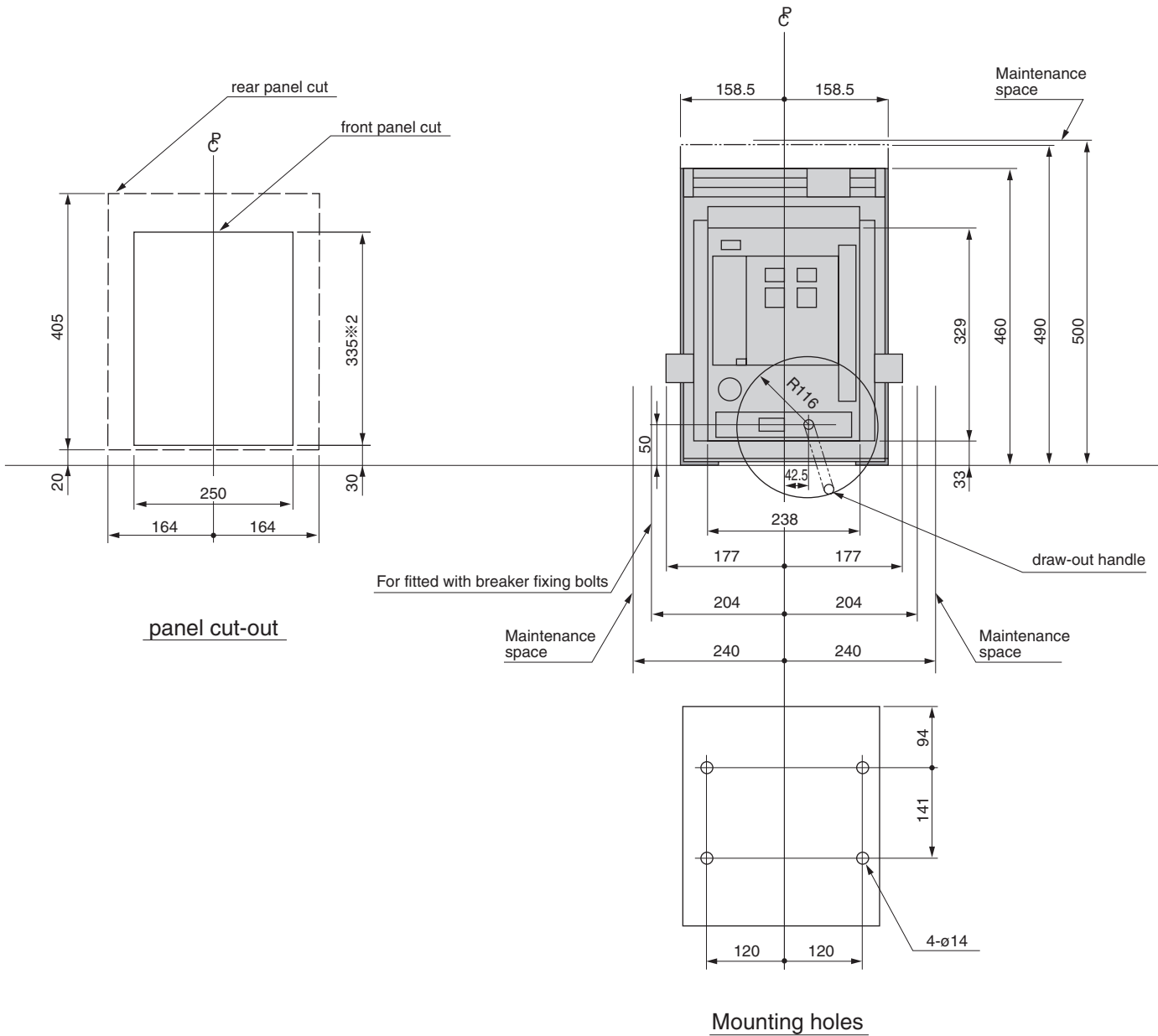

※1 : Conductors including connecting bolts should be separated min-7mm from Draw-out arm.
 ※2 : Panel cut should be 339 mm not 335 mm when the door flange is used.

AR208S 3P, AR212S 3P, AR216S 3P, AR220S 3P

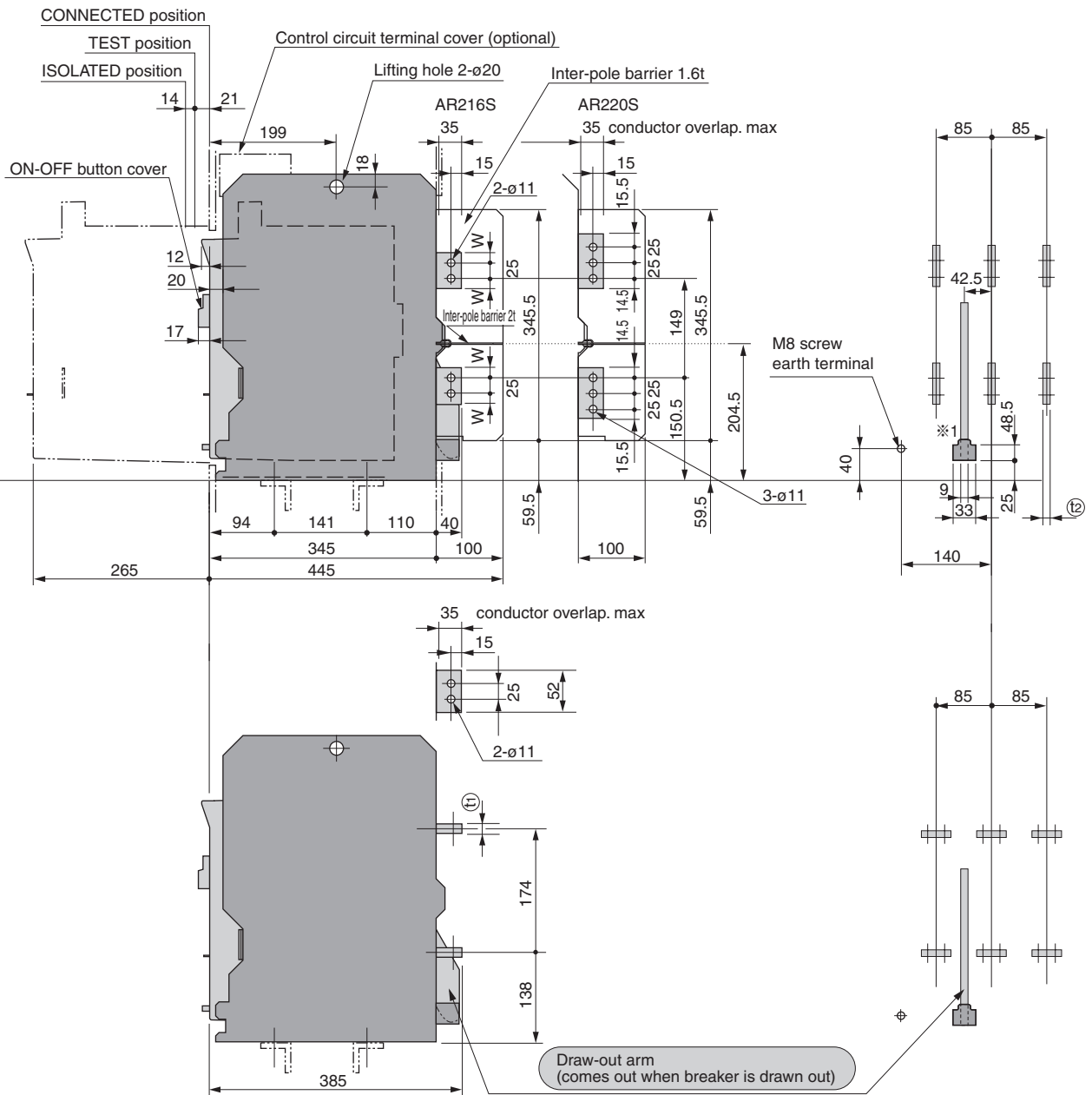
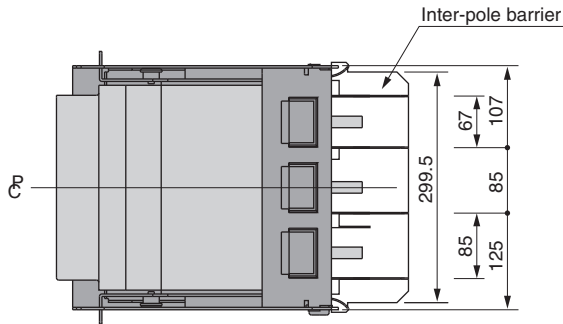

DC Air Circuit Breakers

Outline dimensions (mm)

- Type AR325S 3P, AR332S 3P Draw-out type

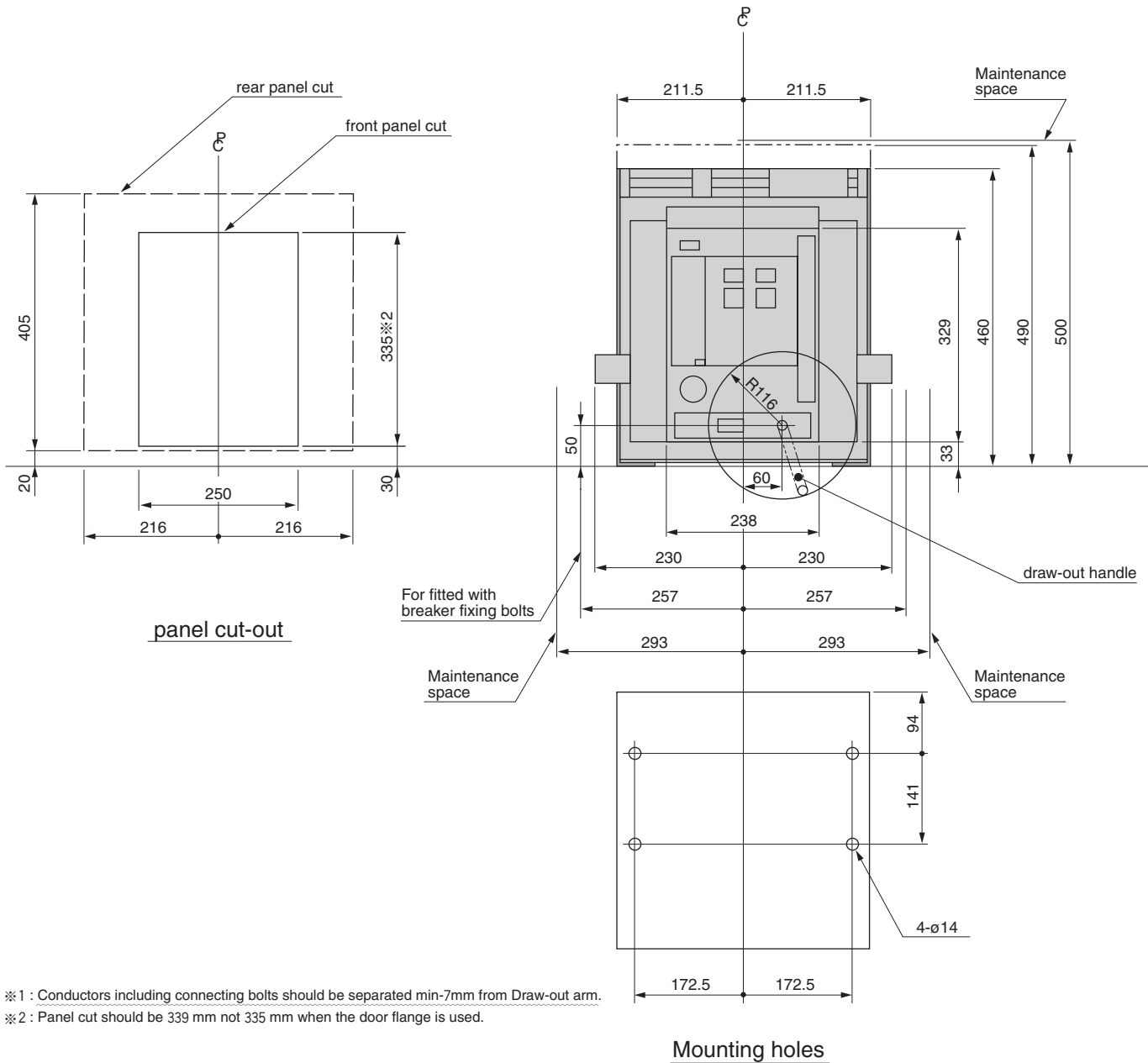

※1 : Conductors including connecting bolts should be separated min-7mm from Draw-out arm.
 ※2 : Panel cut should be 339 mm not 335 mm when the door flange is used.

AR325S 3P, AR332S 3P

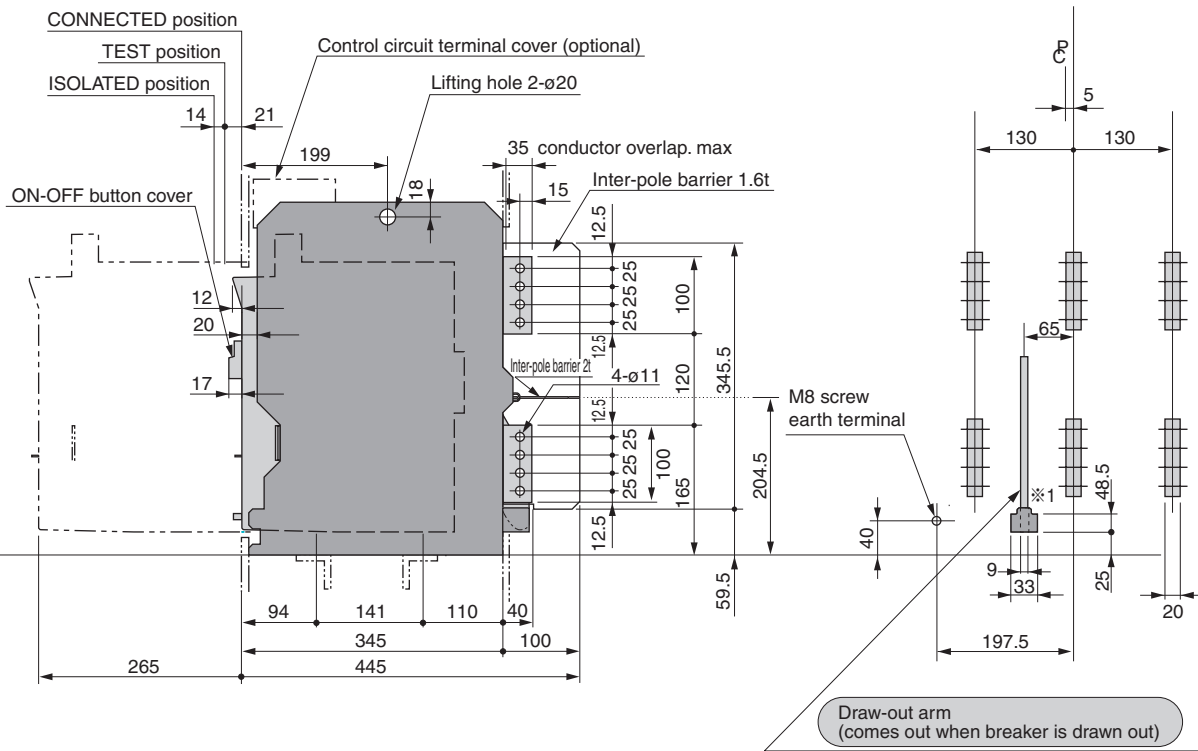
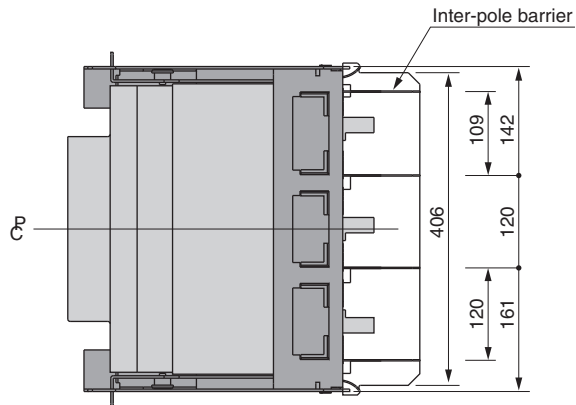

DC Air Circuit Breakers

Outline dimensions (mm)

- Type AR325-NDH 4P Draw-out type

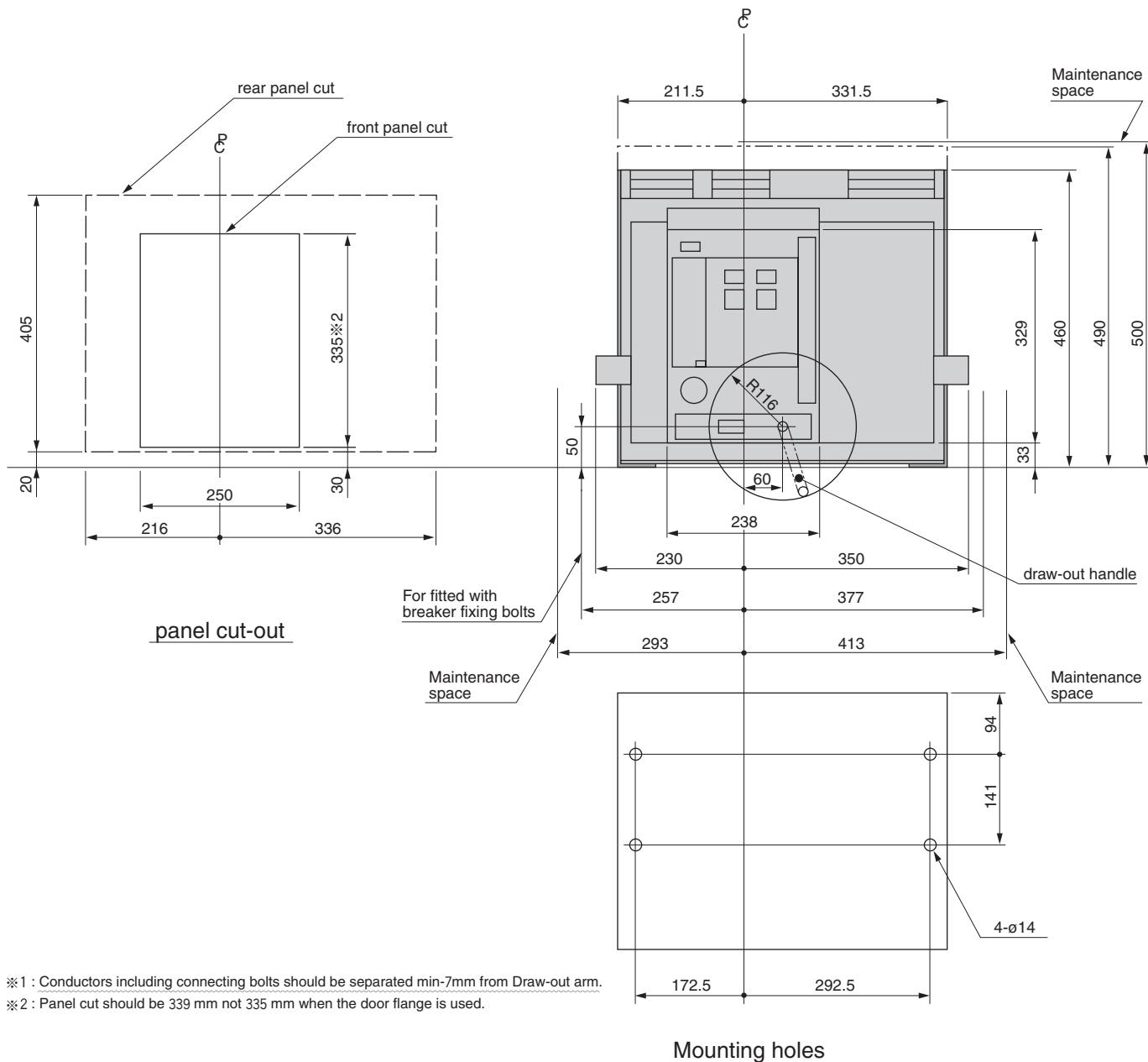

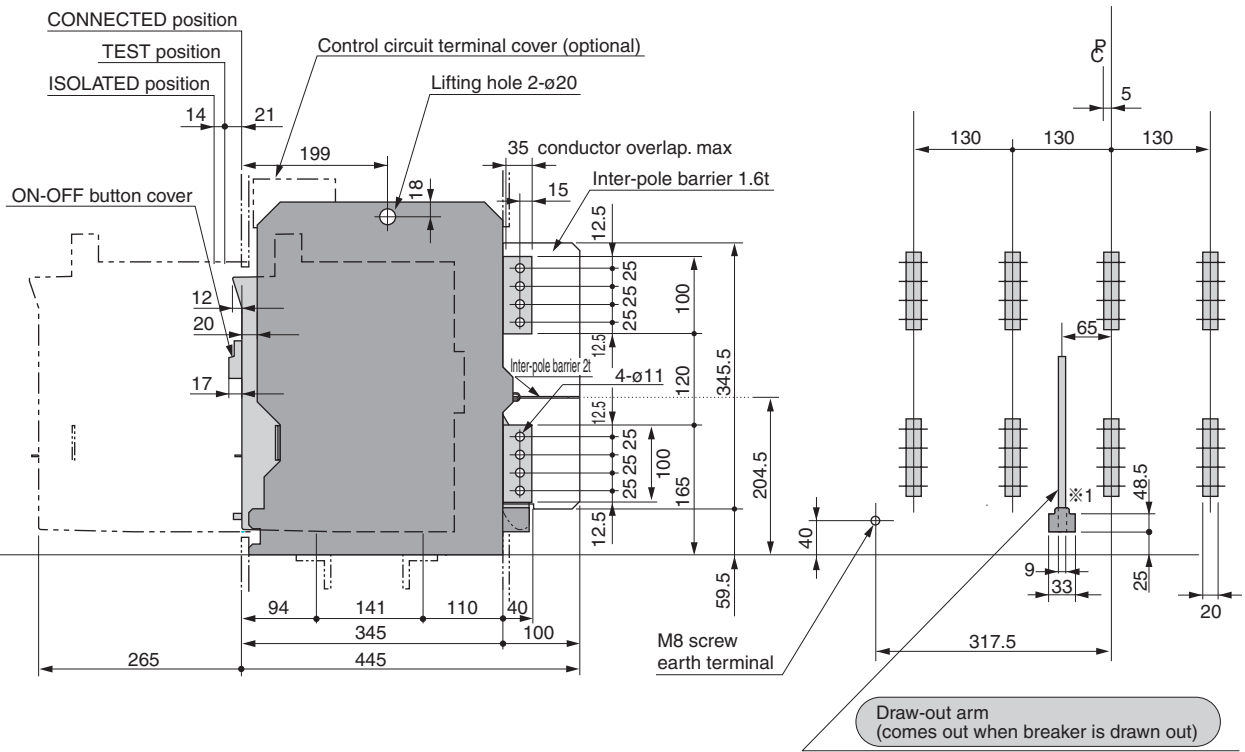
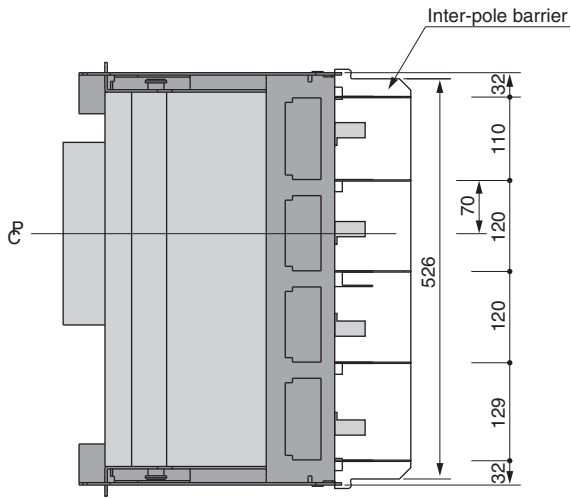

DC Air Circuit Breakers

Outline dimensions (mm)

- Type AR440S 3P Draw-out type

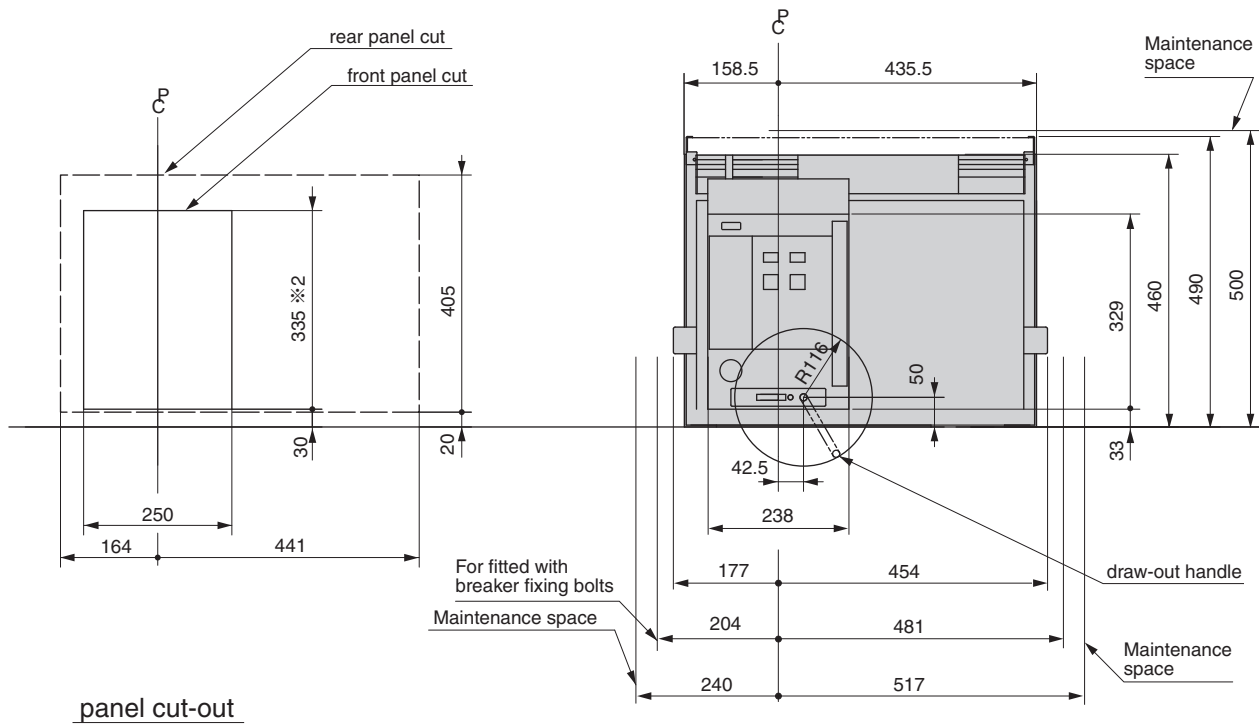

※1 : Conductors including connecting bolts should be separated min-7mm from Draw-out arm.

※2 : Panel cut should be 339 mm not 335 mm when the door flange is used.

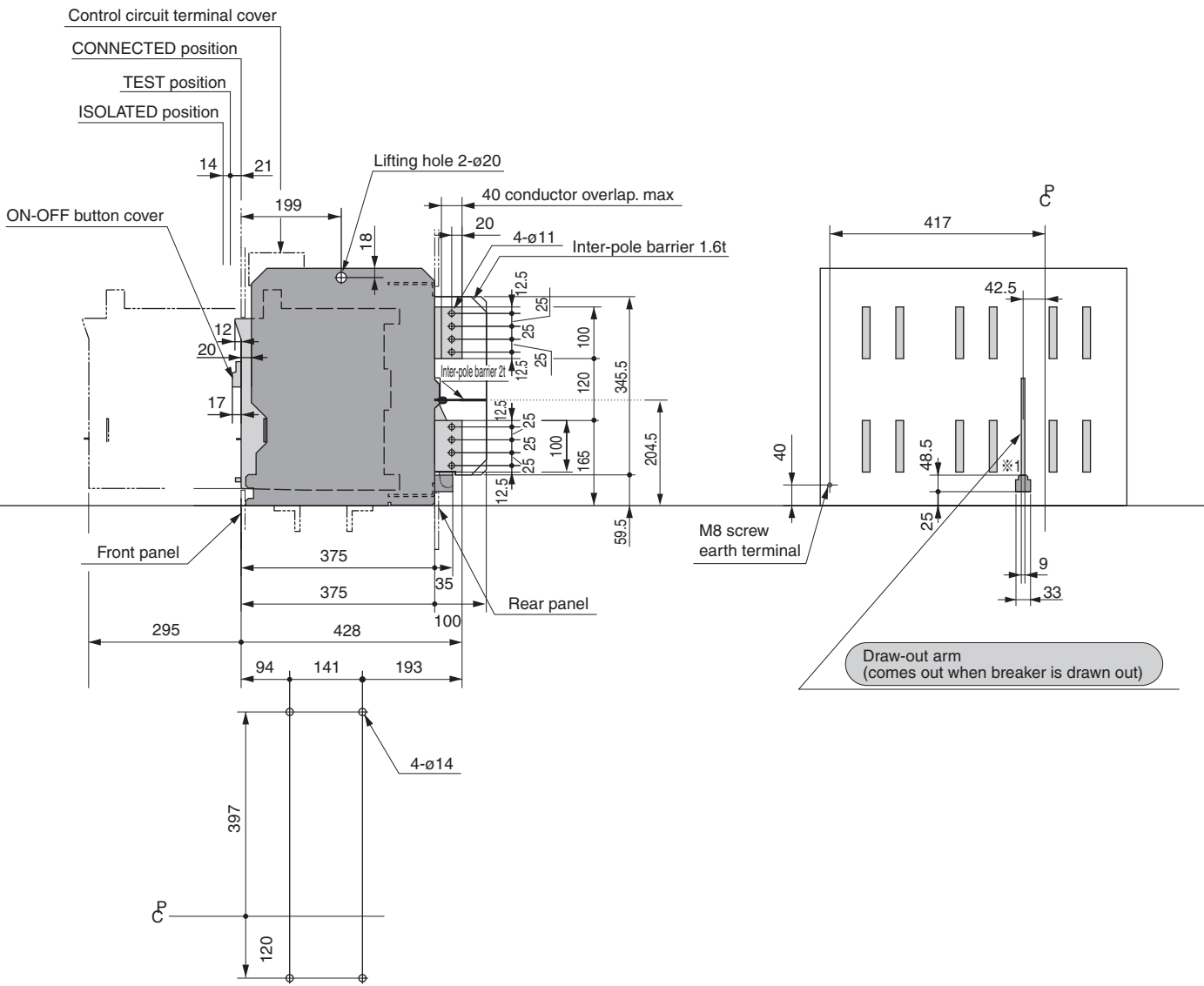
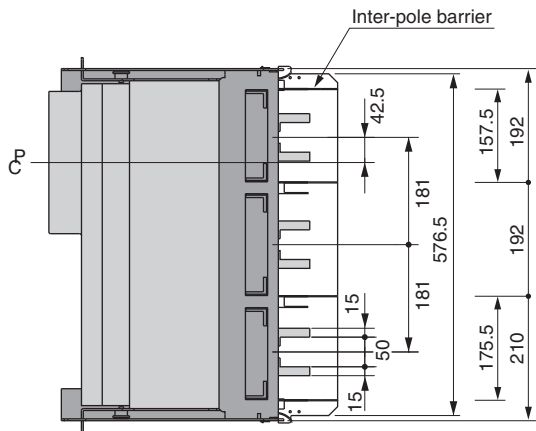

DC Moulded Case Circuit Breakers

ASL: Arrangement Standard Line

HL: Handle Frame Centre Line CL: Handle Centre Line

Outline dimensions (mm) S160-SD 3P, S160-GD 3P, S160-SDN 3P

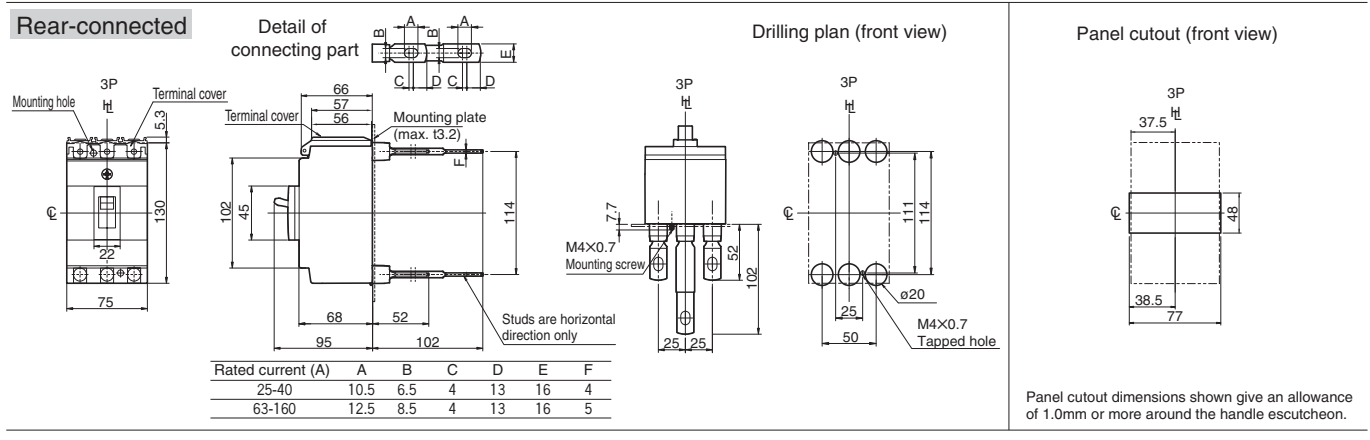
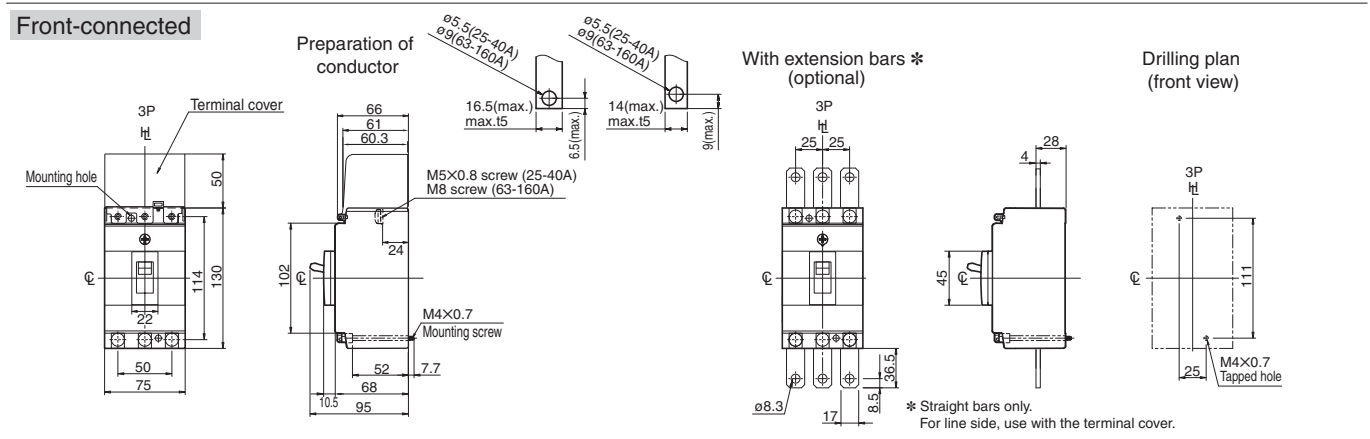

Outline dimensions (mm) S250-SD 3P, S250-GD 3P, S250-SDN 3P

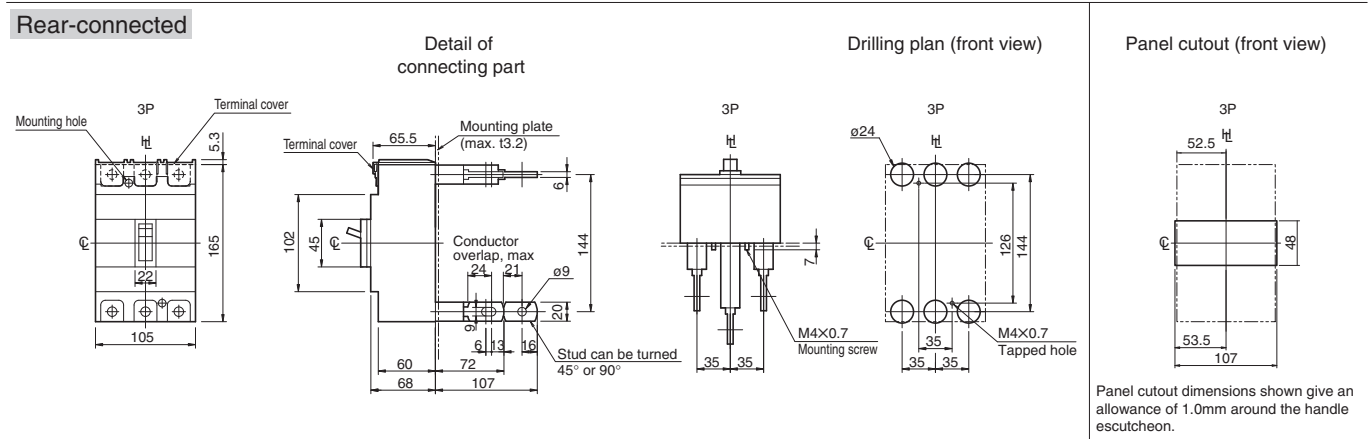
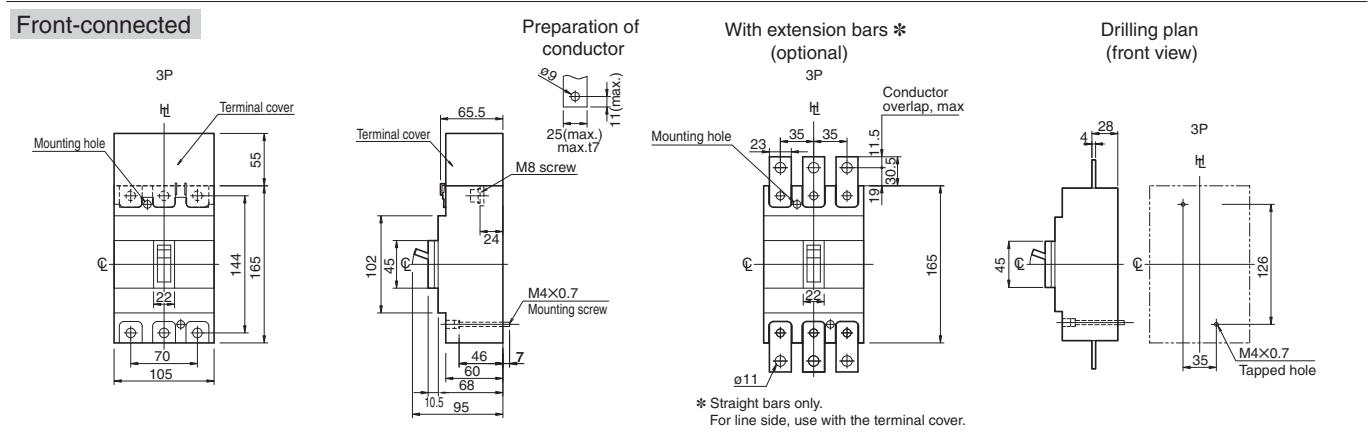

Outline dimensions (mm)

S400-ND 3P

Front-connected

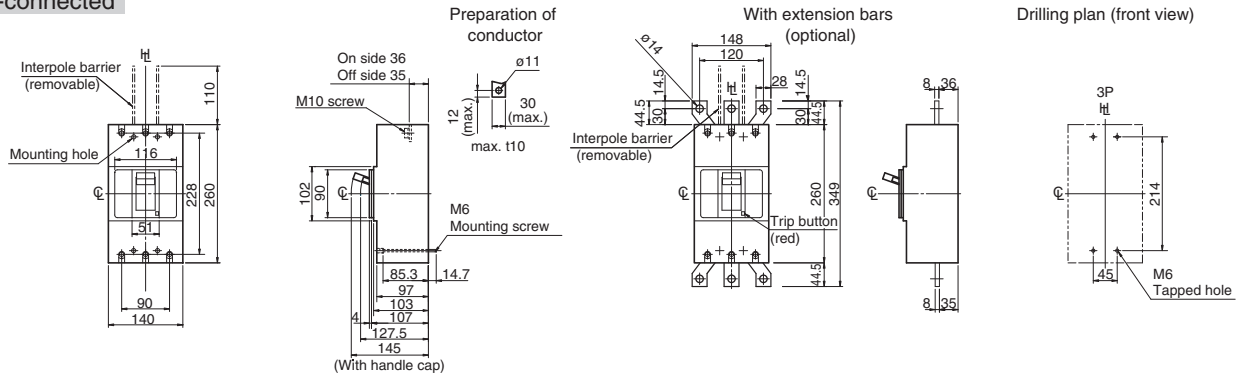

Rear-connected

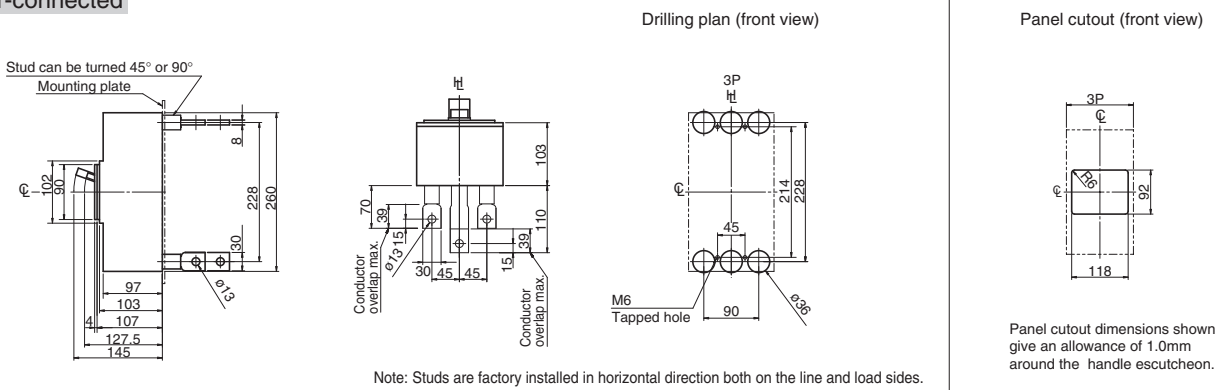

Outline dimensions (mm)

S800-ND 3P

Front-connected

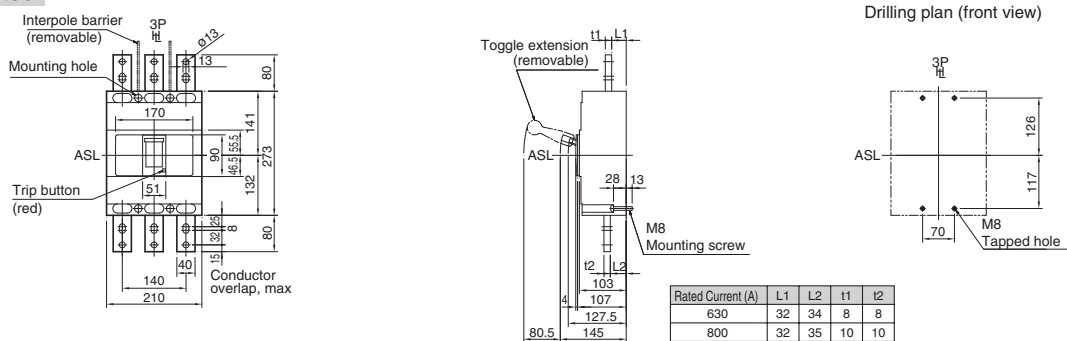

Rear-connected

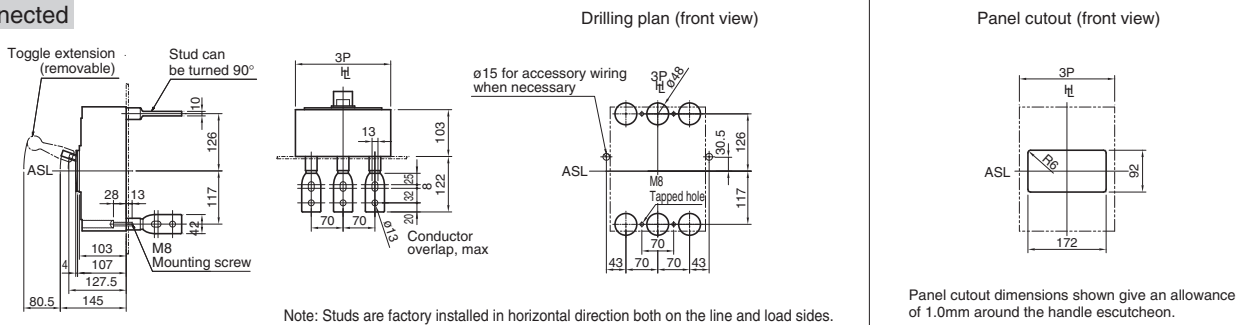

DC Moulded Case Circuit Breakers

ASL: Arrangement Standard Line

HL: Handle Frame Centre Line CL: Handle Centre Line

Outline dimensions (mm)

S1000-ND 2P, 3P

Front-connected

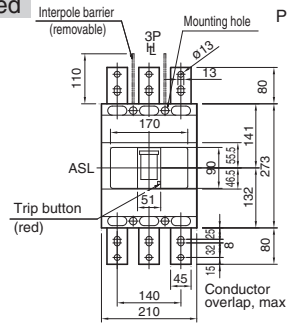

Preparation of conductor

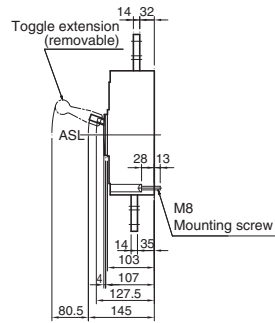

Drilling plan (front view)

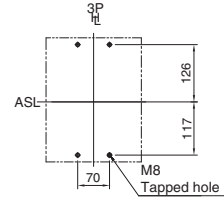

Rear-connected

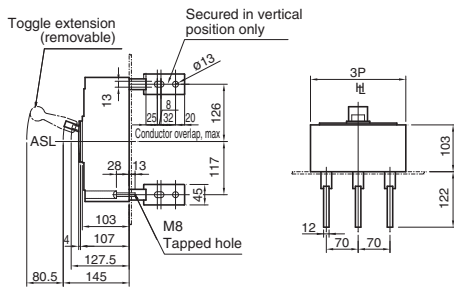

Drilling plan (front view)

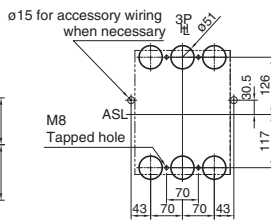

Panel cutout (front view)

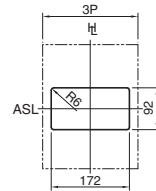

Panel cutout dimensions shown give an allowance of 1.0mm around the handle escutcheon.

Note: 2 poles breaker is same outline dimensions as 3 poles breaker.

Outline dimensions (mm)

XS1250ND 2P, 3P

Front-connected

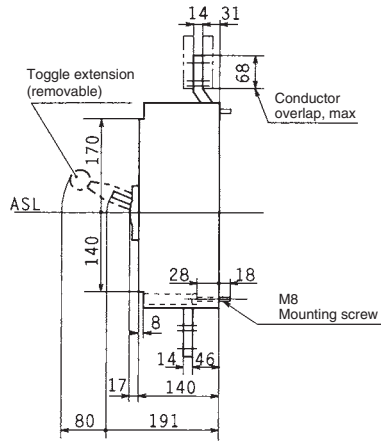
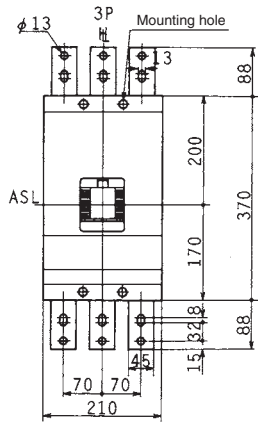

Drilling plan (front view)

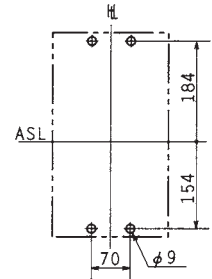

Rear-connected

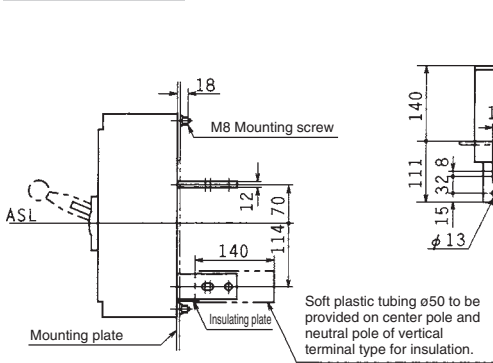

Note: Studs are factory installed in horizontal direction both on the line and load sides. Please specify when ordering if vertical direction is required.

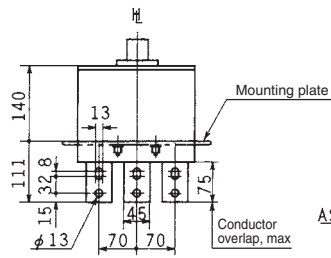

Drilling plan (front view)

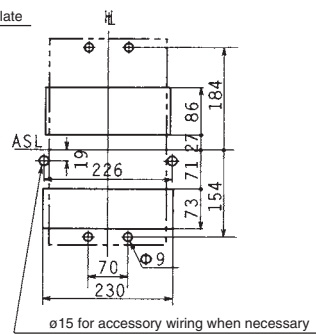

Panel cutout (front view)

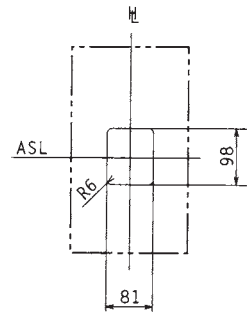

Panel cutout dimensions shown give an allowance of 1.5mm around the handle escutcheon.

Note: 2 poles breaker is same outline dimensions as 3 poles breaker.

DC Moulded Case Circuit Breakers

ASL: Arrangement Standard Line

H: Handle Frame Centre Line H: Handle Centre Line

Outline dimensions (mm)

XS1600ND 2P, 3P

Front-connected

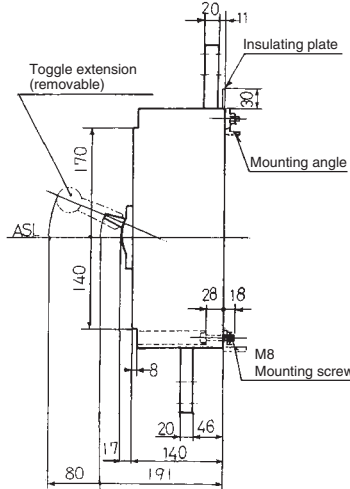
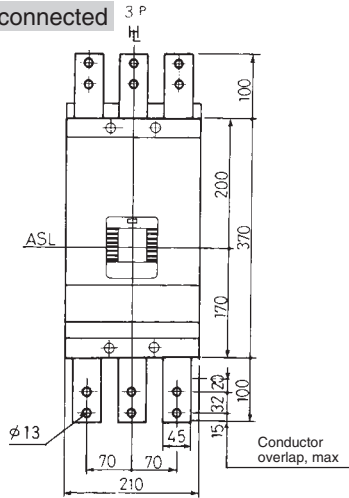

Drilling plan (front view)

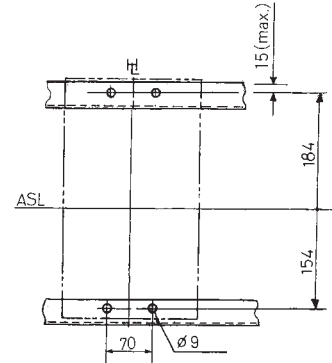

Rear-connected

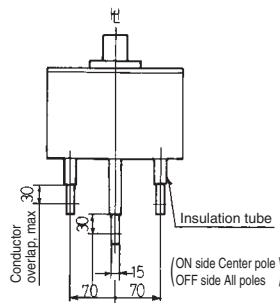
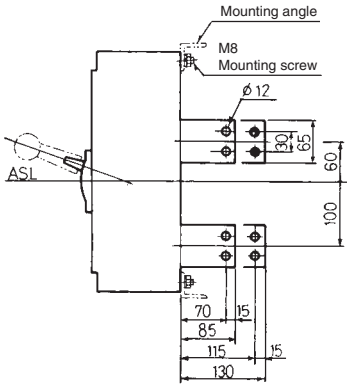

Drilling plan (front view)

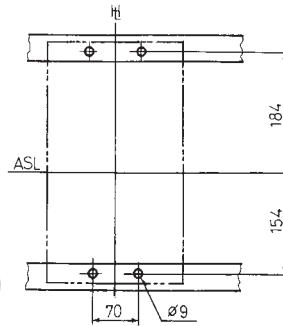

Panel cutout (front view)

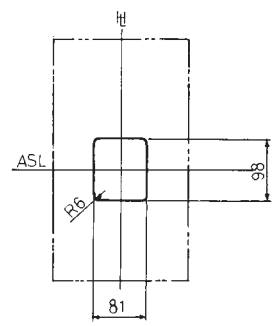

Panel cutout dimensions shown give an allowance of 1.5mm around the handle escutcheon.

Draw-out

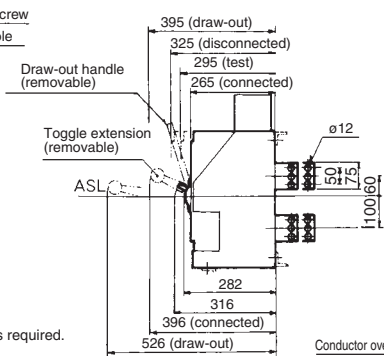
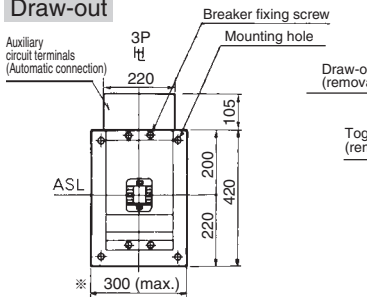

Drilling plan (front view)

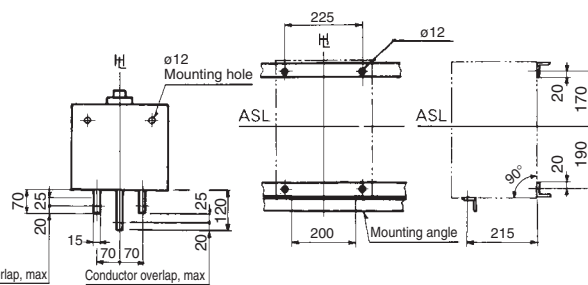

※Contact TERASAKI if manual connection is required.

Note: 2 poles breaker is same outline dimensions as 3 poles breaker.

Outline dimensions (mm)

XS2000ND 2P, 3P

Front-connected

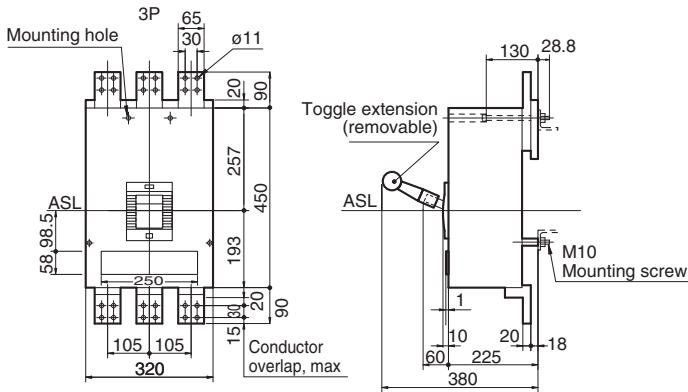

Drilling plan (front view)

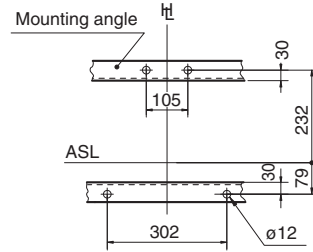

Rear-connected

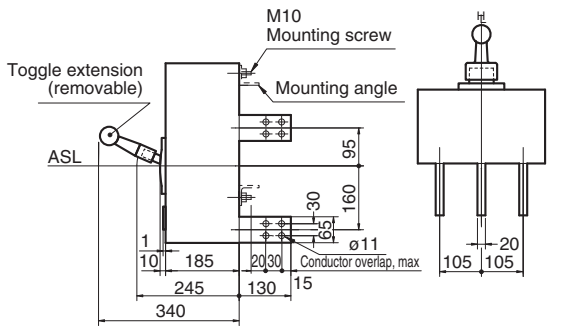

Drilling plan (front view)

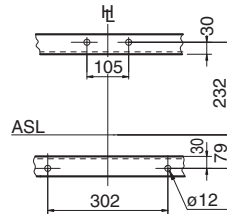

Panel cutout (front view)

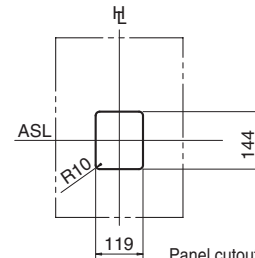

Panel cutout dimensions shown give an allowance of 2mm around the handle escutcheon.

Draw-out

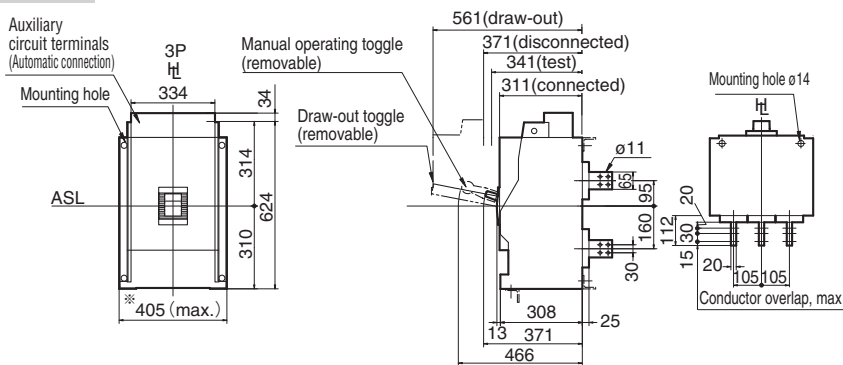

Drilling plan (front view)

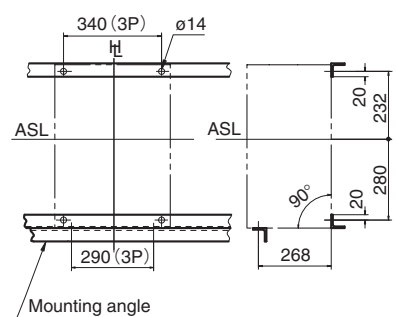

※Contact TERASAKI if manual connection is required.

Note: 2 poles breaker is same outline dimensions as 3 poles breaker.

DC Moulded Case Circuit Breakers

ASL: Arrangement Standard Line

HL: Handle Frame Centre Line CL: Handle Centre Line

Outline dimensions (mm) XS2500ND 2P, 3P, XS3200ND 2P, 3P

Rear-connected

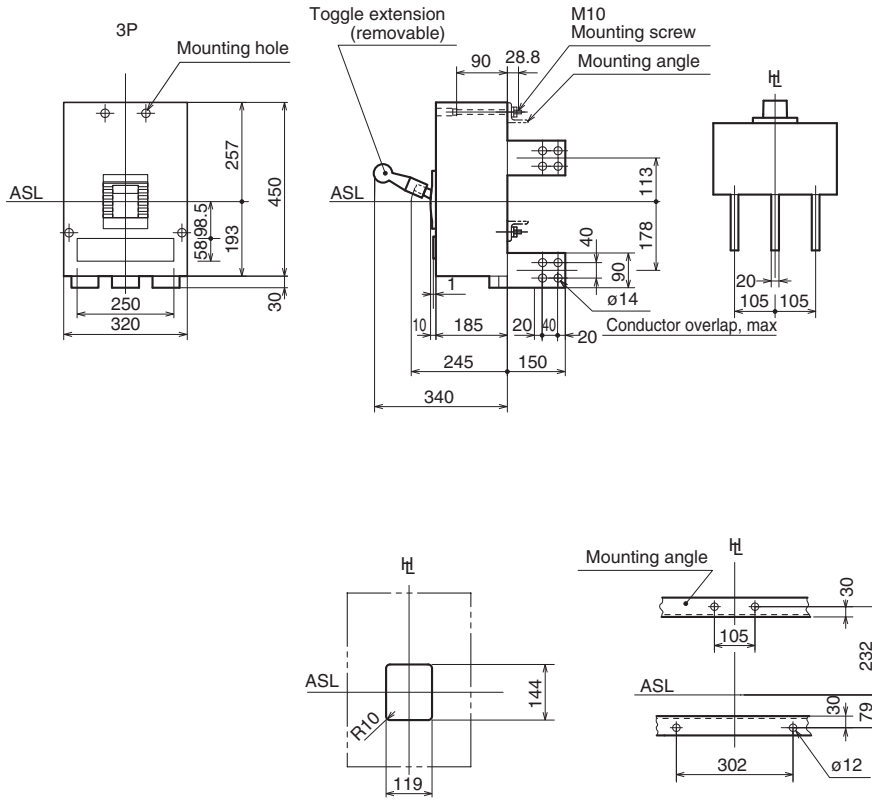

Panel cutout dimensions shown give an allowance of 2mm around the handle escutcheon.

Note: 2 poles breaker is same outline dimensions as 3 poles breaker.

Outline dimensions (mm)

PVE160-SDL 3P

Front-connected

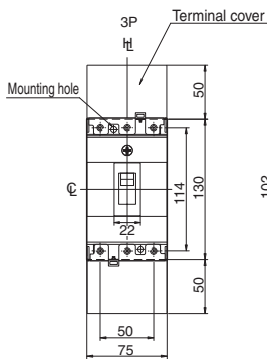

Preparation of conductor

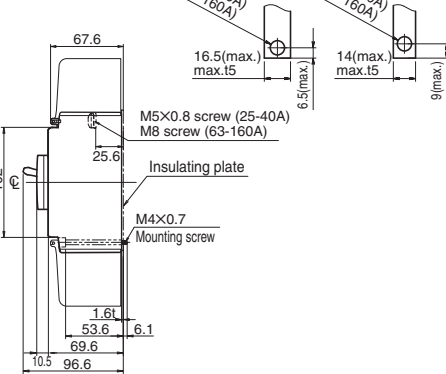

With extension bars * (optional)

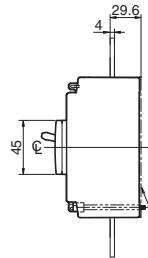
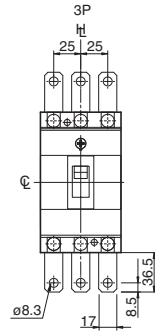

Drilling plan (front view)

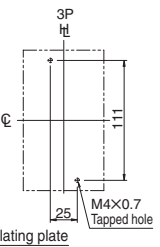

* Straight bars only.
 For line and load side, use with the terminal covers.

Rear-connected

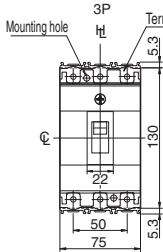

Detail of connecting part

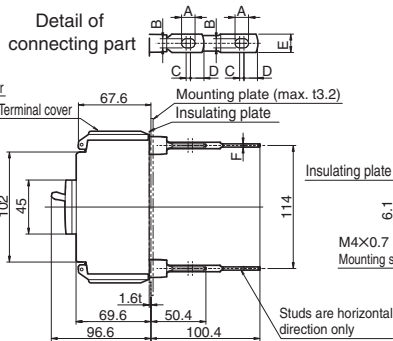

Rated current (A)	A	B	C	D	E	F
25-40	10.5	6.5	4	13	16	4
63-160	12.5	8.5	4	13	16	5

Drilling plan (front view)

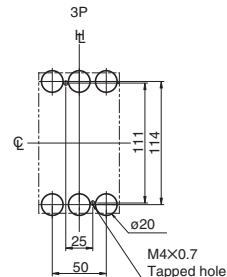

Panel cutout (front view)

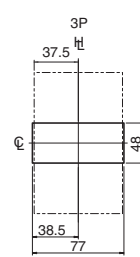

Panel cutout dimensions shown give an allowance of 1.0mm or more around the handle escutcheon.

DC Moulded Case Circuit Breakers

ASL: Arrangement Standard Line

HL: Handle Frame Centre Line CL: Handle Centre Line

Outline dimensions (mm) PVS160-SDL 3P, PVS250-SDL 3P

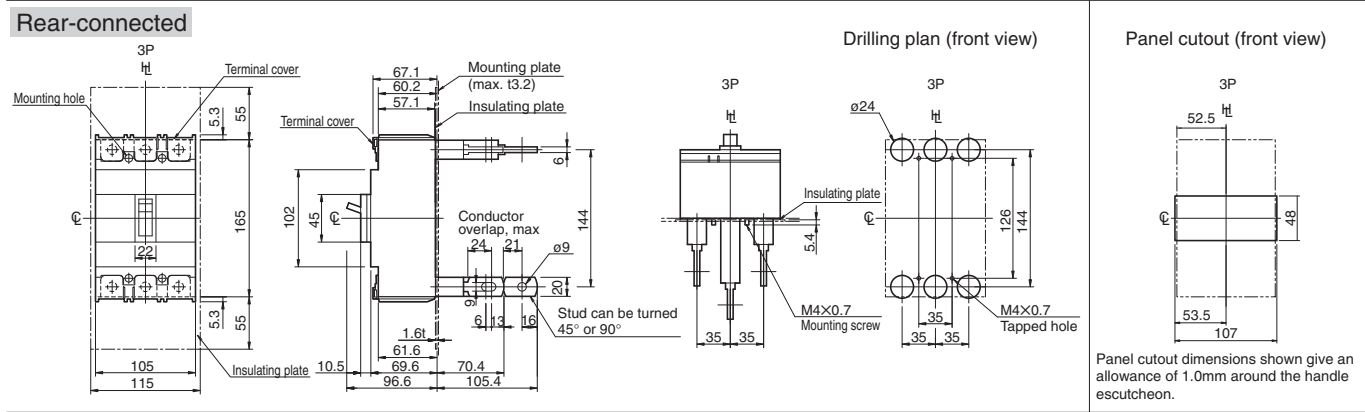
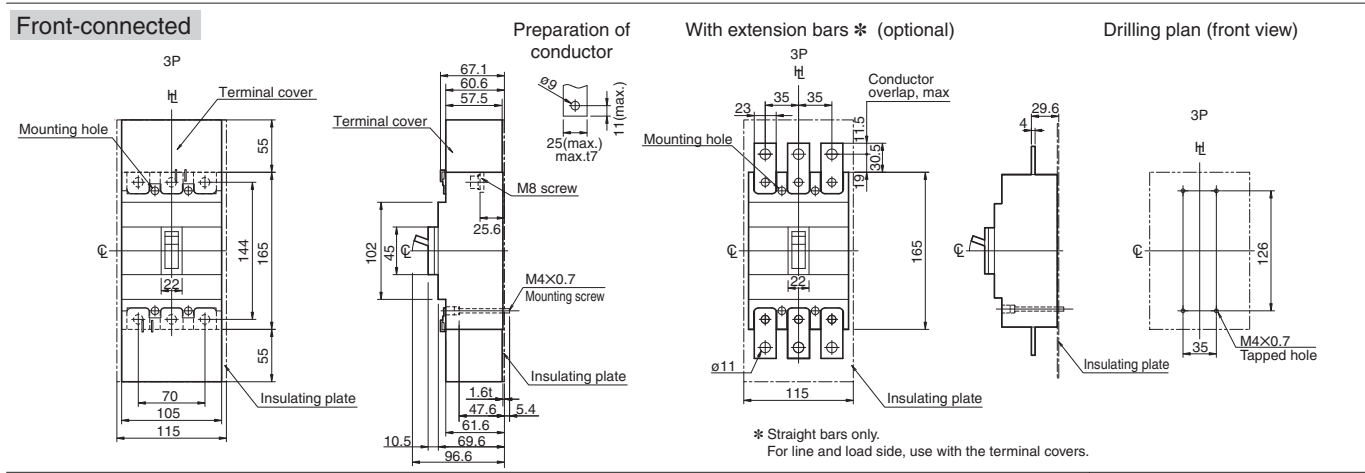

Outline dimensions (mm) PVS250-SNL 3P

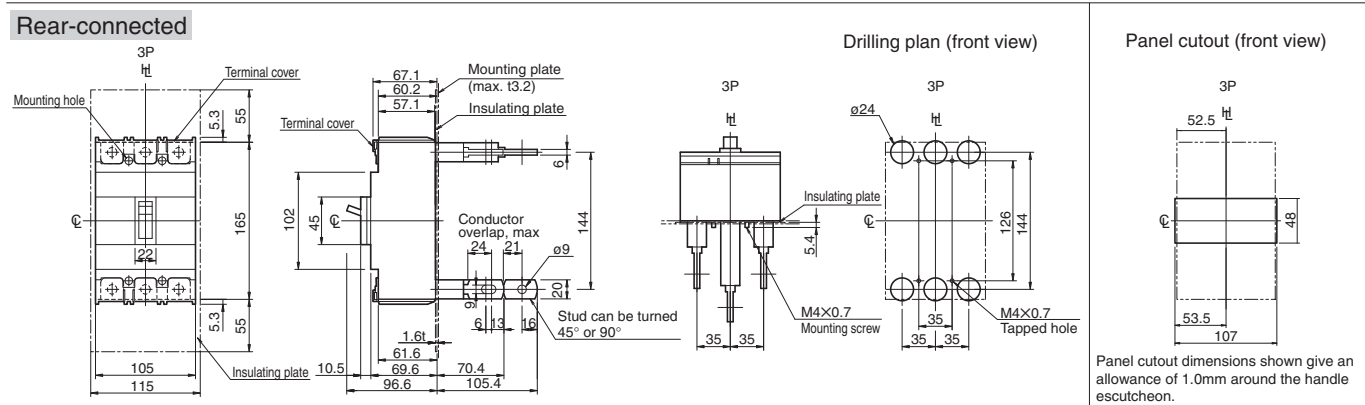
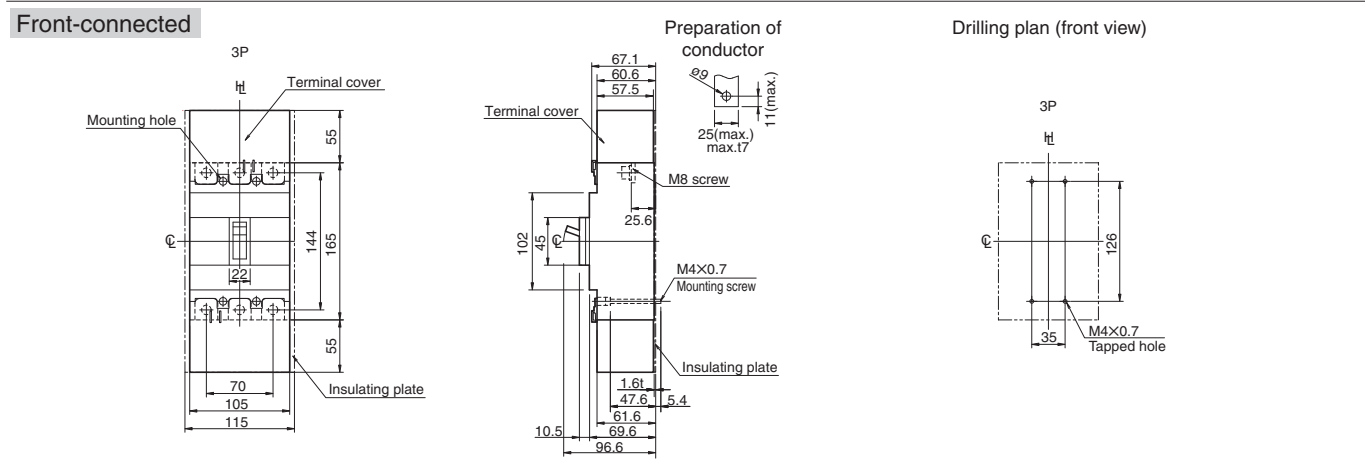

Outline dimensions (mm)

PVS160-SNL 4P, PVS250-SNL 4P

Front-connected

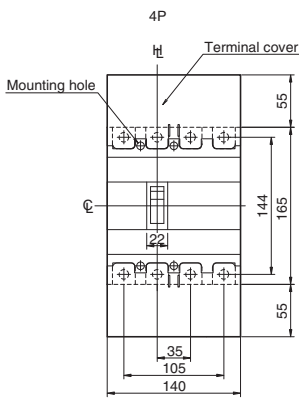

Preparation of conductor

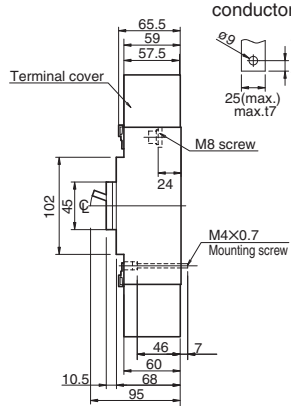

With extension bars * (optional)

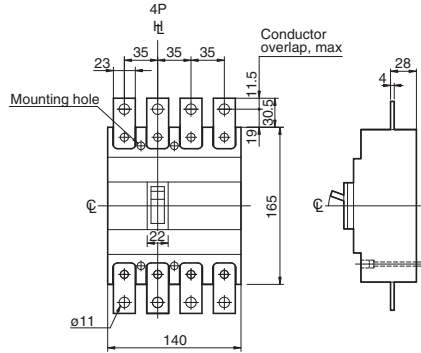

* Straight bars only.
 For line and load side, use with the terminal covers.

Drilling plan (front view)

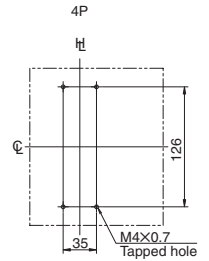

Rear-connected

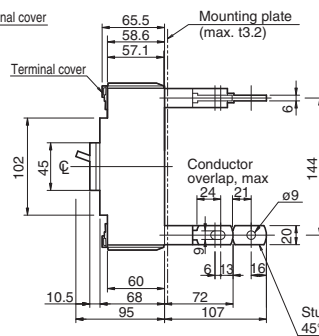
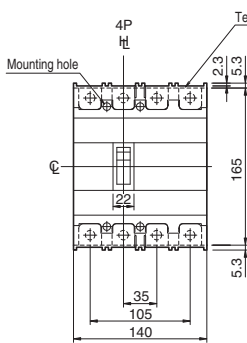

Drilling plan (front view)

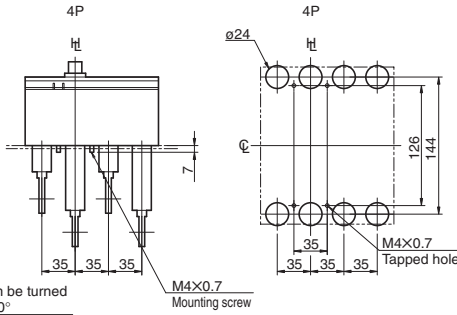

Panel cutout (front view)

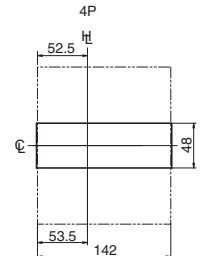

Panel cutout dimensions shown give an allowance of 1.0mm around the handle escutcheon.

Outline dimensions (mm)

PVS160-GDH 4P, PVS250-GDH 4P

Front-connected

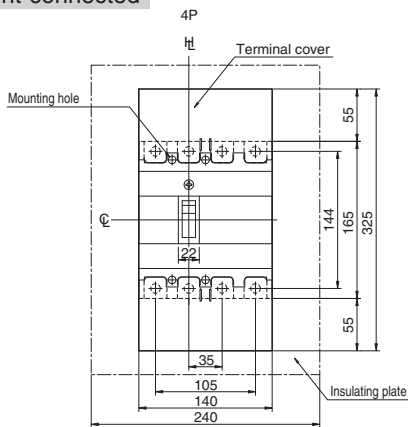

Preparation of conductor

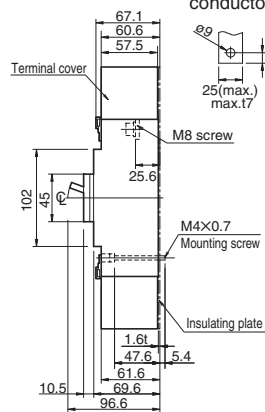

Drilling plan (front view)

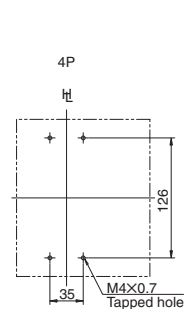

Rear-connected

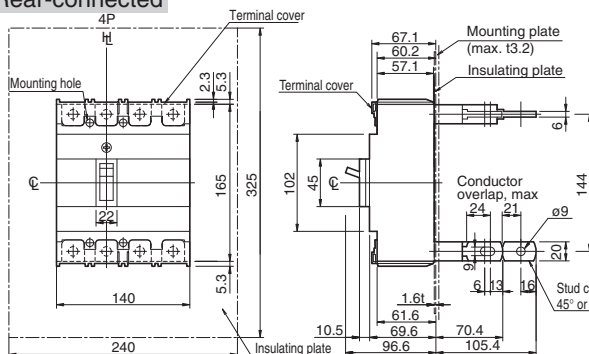

Drilling plan (front view)

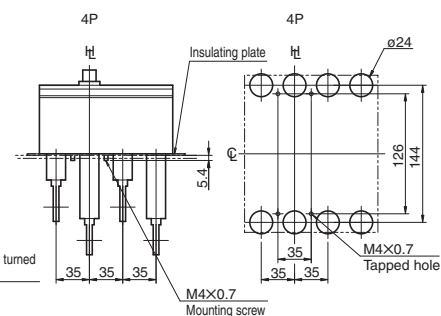

Panel cutout (front view)

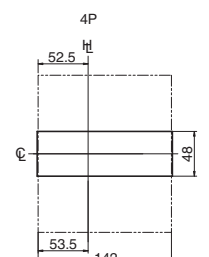

Panel cutout dimensions shown give an allowance of 1.0mm around the handle escutcheon.

DC Moulded Case Circuit Breakers

ASL: Arrangement Standard Line

HL: Handle Frame Centre Line CL: Handle Centre Line

Outline dimensions (mm) PVS160-SDH 4P, PVS250-SDH 4P

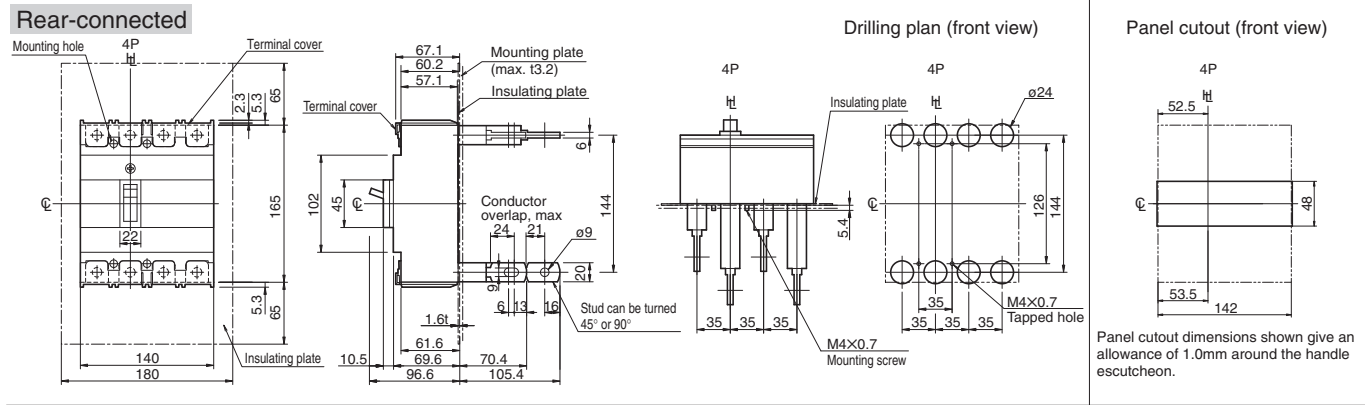
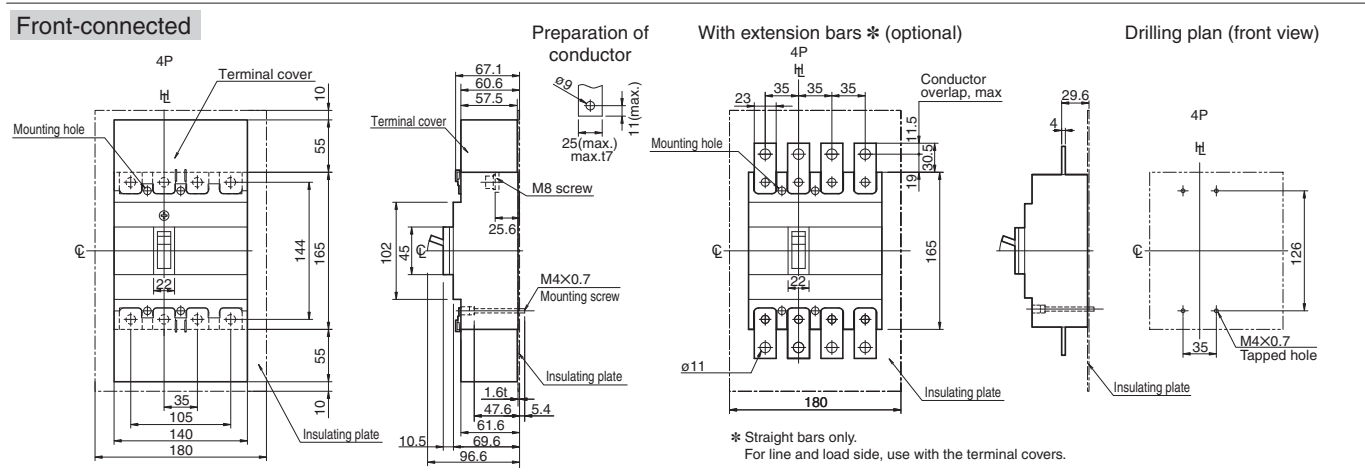

Outline dimensions (mm) PVS160-SNH 4P, PVS250-SNH 4P

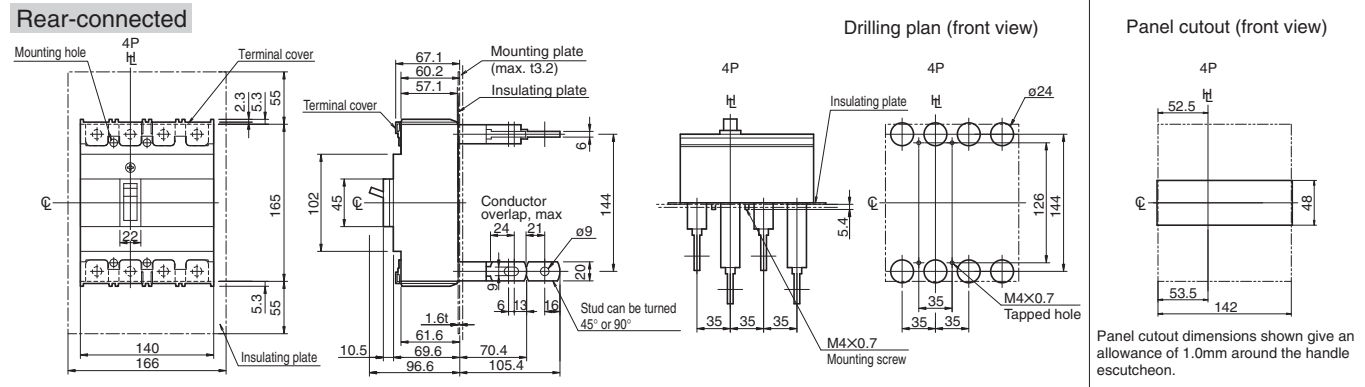
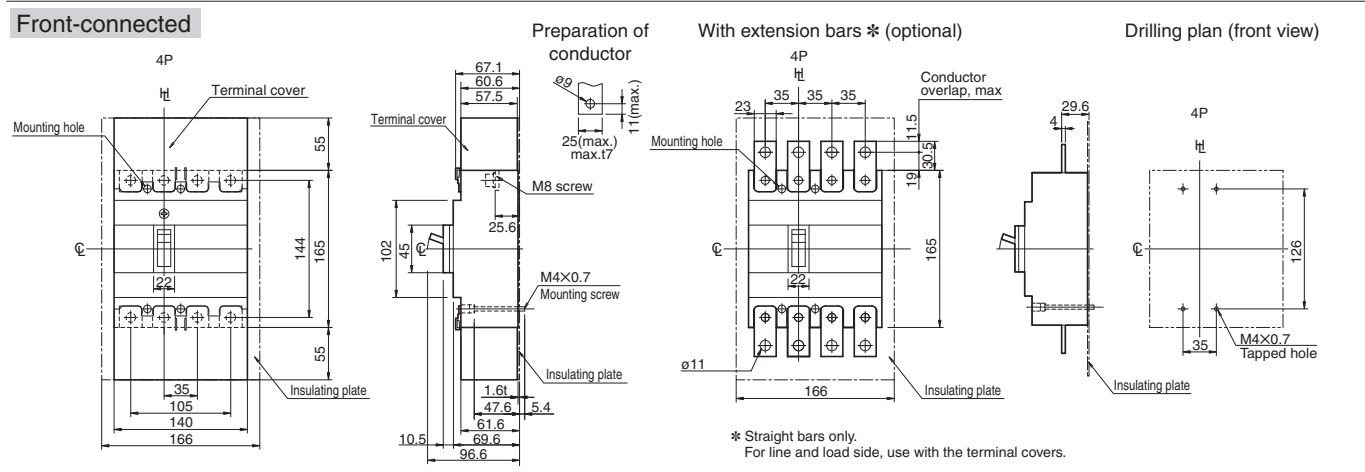

Outline dimensions (mm)

PVS400-NDL 3P

Front-connected

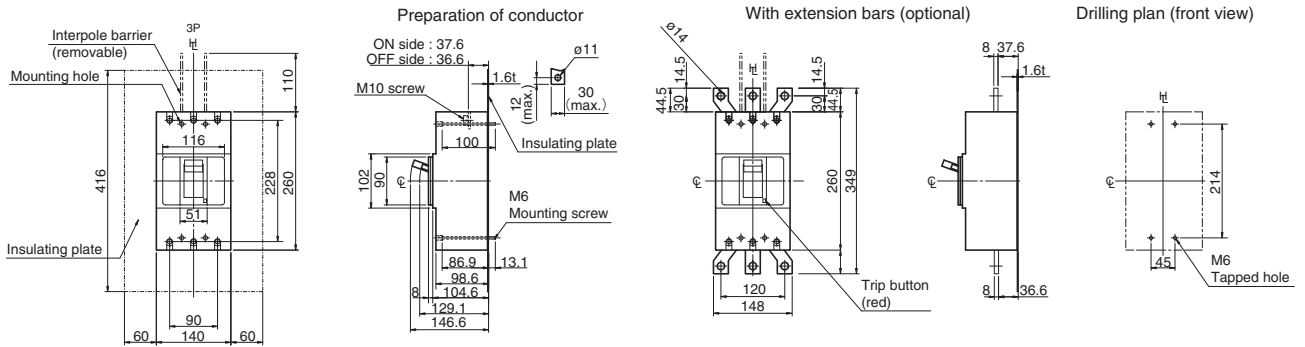

Note: See section 4 for the installation of the insulating plate.

Rear-connected

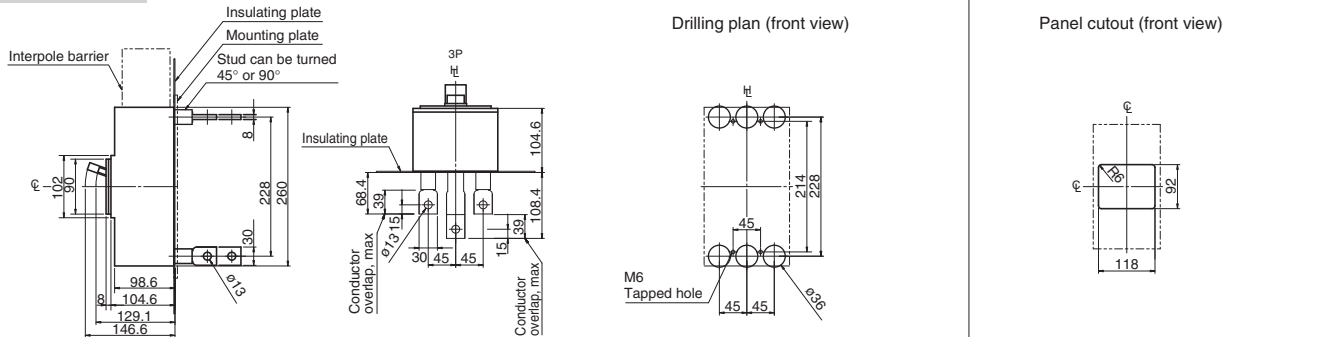

Note: Studs are factory installed in horizontal direction both on the line and load sides. See section 4 for the installation of the insulating plate.

Panel cutout dimensions shown give an allowance of 1.0mm around the handle escutcheon.

Outline dimensions (mm)

PVS400-NDL 4P, PVS400-NDH 4P

Front-connected

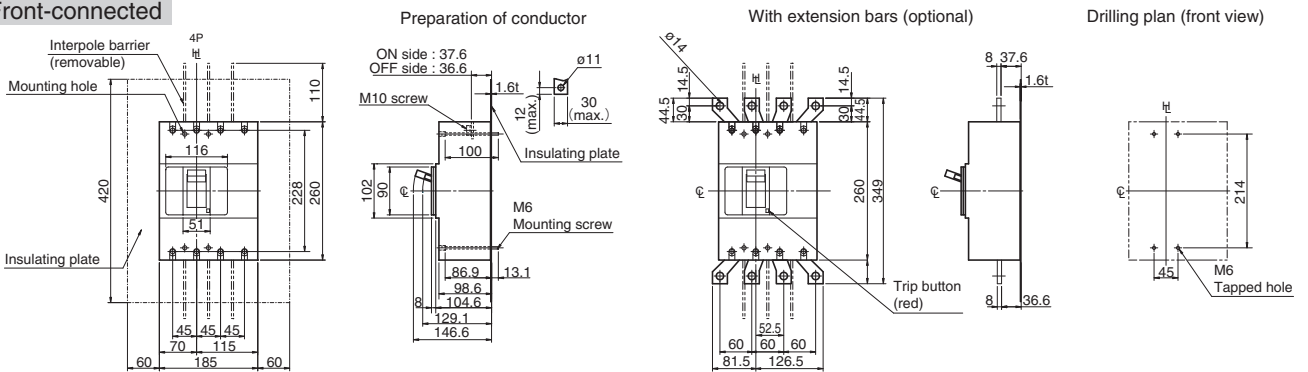

Note: See section 4 for the installation of the insulating plate.

Rear-connected

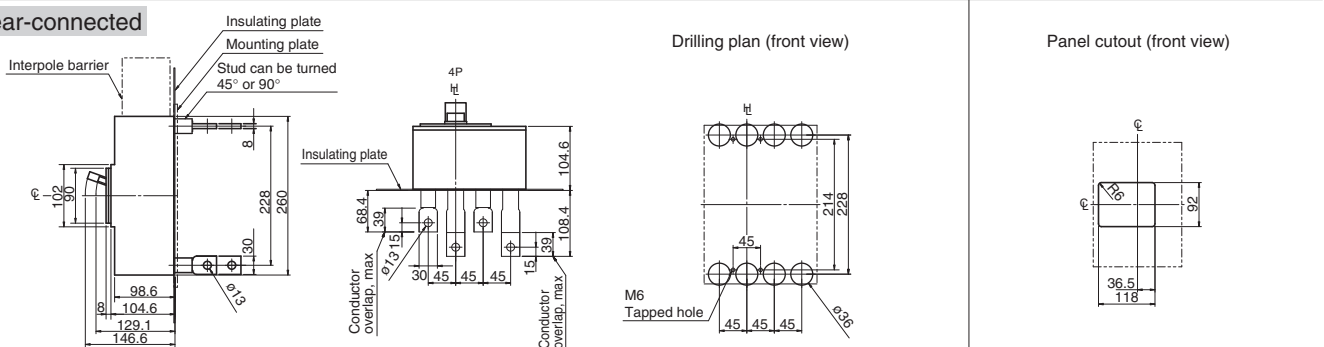

Note: Studs are factory installed in horizontal direction both on the line and load sides. See section 4 for the installation of the insulating plate.

Panel cutout dimensions shown give an allowance of 1.0mm around the handle escutcheon.

DC Moulded Case Circuit Breakers

ASL: Arrangement Standard Line

HL: Handle Frame Centre Line CL: Handle Centre Line

Outline dimensions (mm)

PVS400-NNL 3P

Front-connected

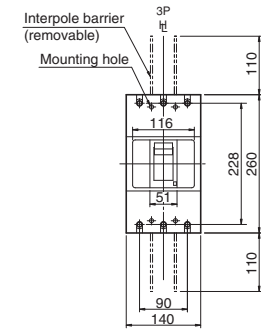

Preparation of conductor

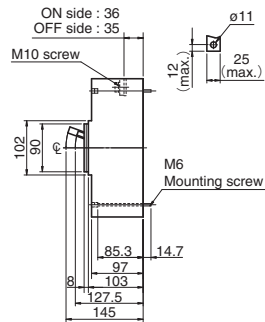

With extension bars (optional)

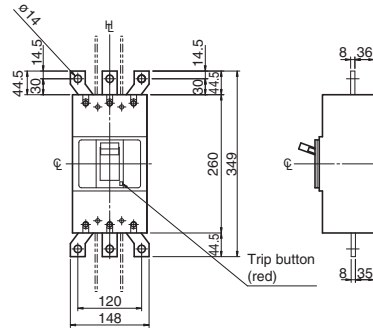

Drilling plan (front view)

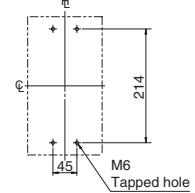

Note: See section 4 for the installation of the insulating plate.

Rear-connected

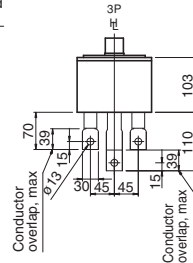
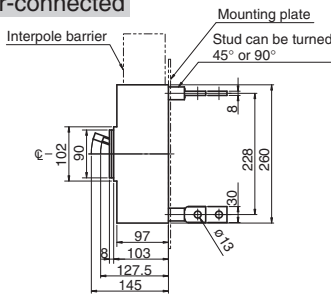

Drilling plan (front view)

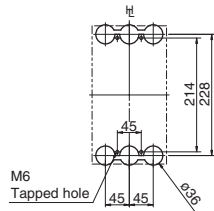

Panel cutout (front view)

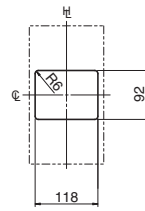

Note: Studs are factory installed in horizontal direction both on the line and load sides. See section 4 for the installation of the insulating plate.

Panel cutout dimensions shown give an allowance of 1.0mm around the handle escutcheon.

Outline dimensions (mm)

PVS400-NNL 4P, PVS400-NNH 4P

Front-connected

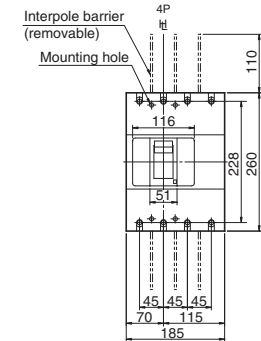

Preparation of conductor

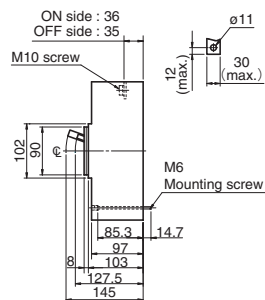

With extension bars (optional)

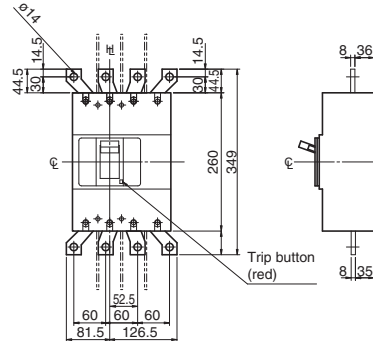

Drilling plan (front view)

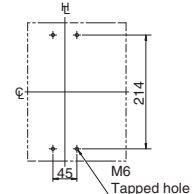

Note: See section 4 for the installation of the insulating plate.

Rear-connected

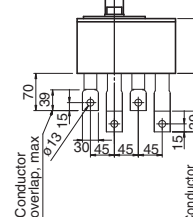
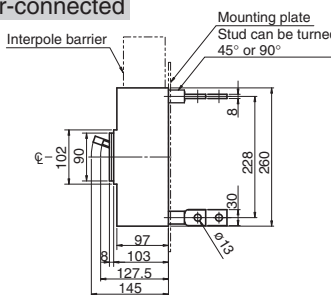

Drilling plan (front view)

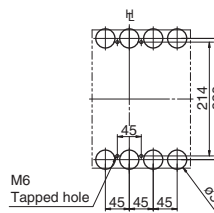

Panel cutout (front view)

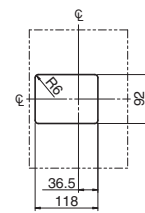

Note: Studs are factory installed in horizontal direction both on the line and load sides. See section 4 for the installation of the insulating plate.

Panel cutout dimensions shown give an allowance of 1.0mm around the handle escutcheon.

Outline dimensions (mm)

PVS800-NDL 3P

Front-connected

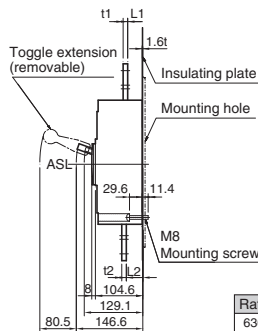
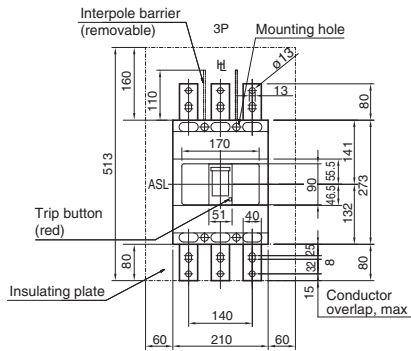

Drilling plan (front view)

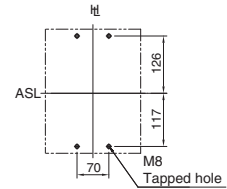

Rated Current (A)	L1	L2	t1	t2
630 (400-630)	33.6	35.6	8	8
800 (500-800)	33.6	36.6	10	10

Note: See section 4 for the installation of the insulating plate.

Rear-connected

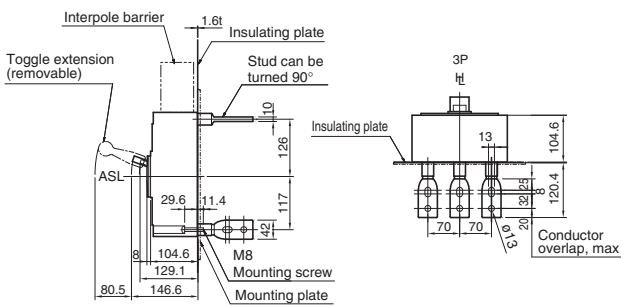

Drilling plan (front view)

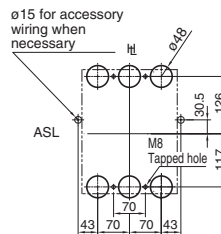

Panel cutout (front view)

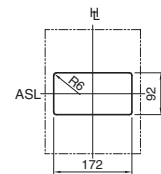

Note: Studs are factory installed in horizontal direction both on the line and load sides. See section 4 for the installation of the insulating plate.

Panel cutout dimensions shown give an allowance of 1.0mm around the handle escutcheon.

Outline dimensions (mm)

PVS800-NDL 4P, PVS800-NDH 4P

Front-connected

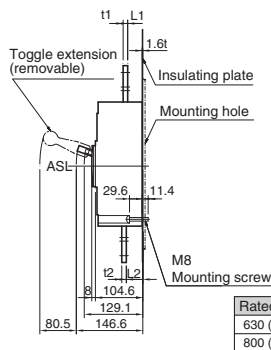
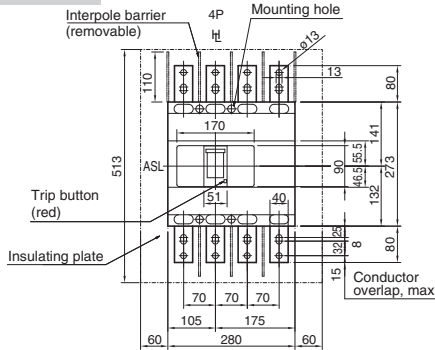

Drilling plan (front view)

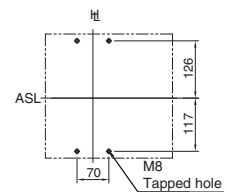

Rated Current (A)	L1	L2	t1	t2
630 (400-630)	33.6	35.6	8	8
800 (500-800)	33.6	36.6	10	10

Note: See section 4 for the installation of the insulating plate.

Rear-connected

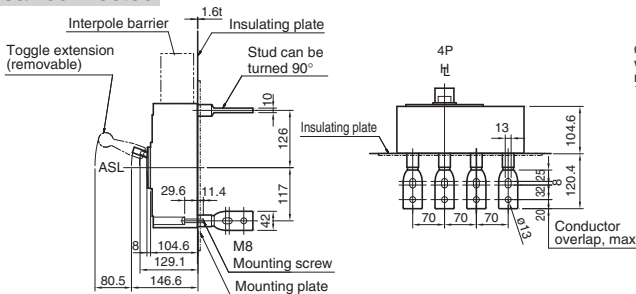

Drilling plan (front view)

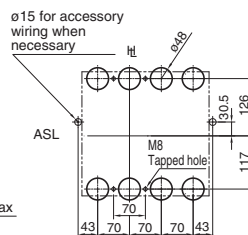

Panel cutout (front view)

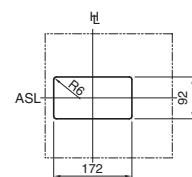

Note: Studs are factory installed in horizontal direction both on the line and load sides. See section 4 for the installation of the insulating plate.

Panel cutout dimensions shown give an allowance of 1.0mm around the handle escutcheon.

DC Moulded Case Circuit Breakers

ASL: Arrangement Standard Line

H: Handle Frame Centre Line H: Handle Centre Line

Outline dimensions (mm)

PVS800-NNL 3P

Front-connected

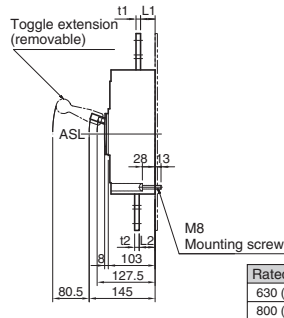
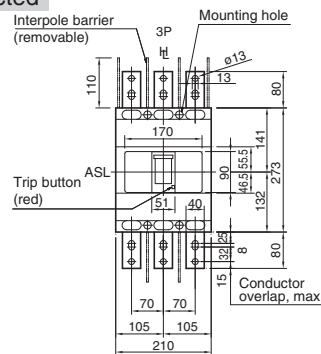

Drilling plan (front view)

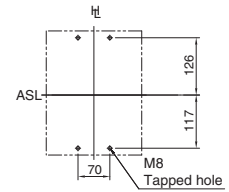

Rated Current (A)	L1	L2	t1	t2
630 (400-630)	32	34	8	8
800 (500-800)	32	35	10	10

Note: See section 4 for the installation of the insulating plate.

Rear-connected

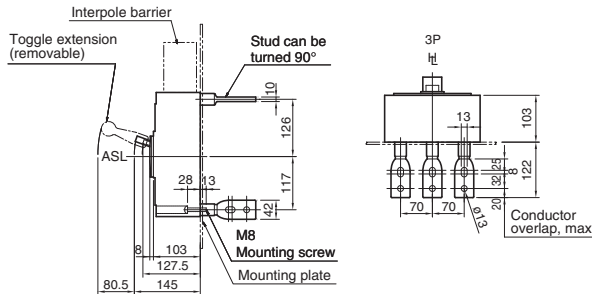

Drilling plan (front view)

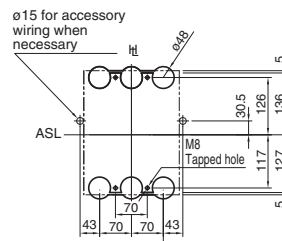

Panel cutout (front view)

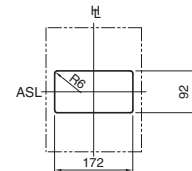

Note: Studs are factory installed in horizontal direction both on the line and load sides. See section 4 for the installation of the insulating plate.

Panel cutout dimensions shown give an allowance of 1.0mm around the handle escutcheon.

Outline dimensions (mm)

PVS800-NNL 4P, PVS800-NNH 4P

Front-connected

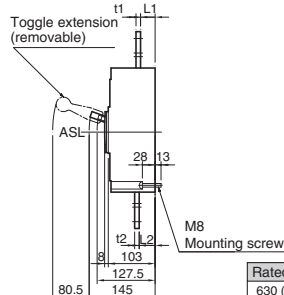
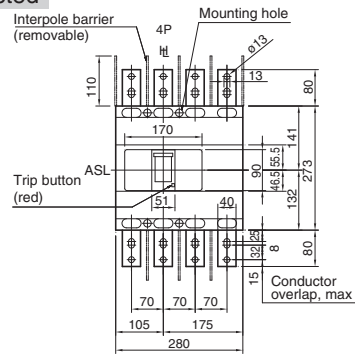

Drilling plan (front view)

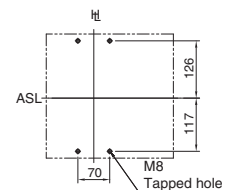

Rated Current (A)	L1	L2	t1	t2
630 (400-630)	32	34	8	8
800 (500-800)	32	35	10	10

Note: See section 4 for the installation of the insulating plate.

Rear-connected

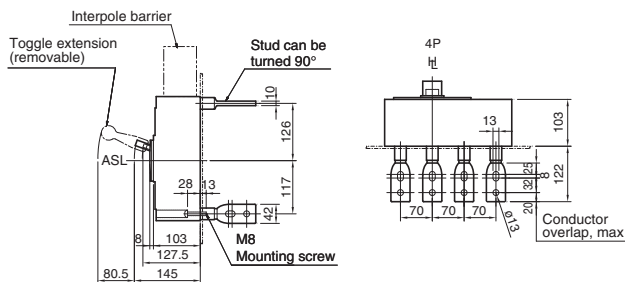

Drilling plan (front view)

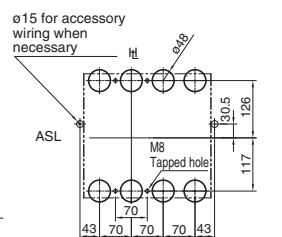

Panel cutout (front view)

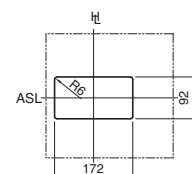

Note: Studs are factory installed in horizontal direction both on the line and load sides. See section 4 for the installation of the insulating plate.

Panel cutout dimensions shown give an allowance of 1.0mm around the handle escutcheon.



TERASAKI ELECTRIC (M) SDN, BHD.

Lot 3, Jalan 16/13D, 40000 Shah Alam, Selangor Darul Ehsan, Malaysia

TEL +60-3-5549-3820

FAX +60-3-5549-3960

terasaki@terasaki.com.my

TERASAKI ELECTRIC TRADING & SERVICES (M) SDN. BHD.

No. 20 & 22, Jalan Rajawali 2, Bandar Puchong Jaya, Jalan Puchong, 47100 Selangor Darul Ehsan, Malaysia

TEL +60-3-8070-2486, +60-3-8075-1542

FAX +60-3-8070-2481

sales@terasaki.com.my

TERASAKI DO BRASIL LTDA.

Rua Olof Palme, No. 765, Barra da Tijuca - Rio de Janeiro, Brazil

TEL +55-21-3301-9898

FAX +55-21-3301-9861

terasaki@terasaki.com.br

<http://www.terasaki.com.br>

TERASAKI ELECTRIC (CHINA) LTD.

No.1, 5th Road Pacific Xintang, Zengcheng Ariea, Guangzhou, 511340, China

TEL +86-20-8270-8556

FAX +86-20-8270-8586

terasaki@public.guangzhou.gd.cn

TERASAKI ELECTRIC GROUP SHANGHAI REPRESENTATIVE OFFICE

Room No. 1405-6, Tomson Commercial Building

710 Dong Fang Road, Pudong, Shanghai, 200122, China

TEL +86-21-58201611

FAX +86-21-58201621

terasaki@vip.163.com



Latest data can download by matrix code.

Ratings and specifications are subject to change without notice.

CAT REF. **18-I73E**

TERASAKI ELECTRIC CO., LTD.

Head Office: 6-13-47 Kamihigashi, Hirano-ku, Osaka 547-0002, Japan

Circuit Breaker Division: 6-13-47 Kamihigashi, Hirano-ku,

Osaka 547-0002, Japan

TEL +81-6-6791-2763

FAX +81-6-6791-2732

int-sales@terasaki.co.jp

<http://www.terasaki.co.jp/>

TERASAKI ELECTRIC (EUROPE) LTD.

80 Beardmore Way, Clydebank Industrial Estate

Clydebank, Glasgow, G81 4HT, Scotland (UK)

TEL +44-141-941-1940

FAX +44-141-952-9246

marketing@terasaki.co.uk

<http://www.terasaki.com/>

TERASAKI ELECTRIC (EUROPE) LTD. FILIALE ITALIA

Via Ambrosoli, 4A-20090 Rodano, Milano, Italy

TEL +39-02-92278300

FAX +39-02-92278320

terasaki@terasaki.it

<http://www.terasaki.it/>

TERASAKI ELECTRIC (EUROPE) LTD. SUCURSAL EN ESPAÑA

Pol. Ind. Coll de la Manyà, C/Cal Ros dels Ocells 5-7,

08403 Granollers, Barcelona, Spain

TEL +34-93-879-60-50

FAX +34-93-870-39-05

terasaki@terasaki.es

<http://www.terasaki.es/>

TERASAKI ELECTRIC (EUROPE) LTD. FILIAL SVERIGE

Box 2082 SE-128 22 Skarpnäck Sweden

TEL +46-8-556-282-30

FAX +46-8-556-282-39

info@terasaki.se

<http://www.terasaki.se/>

TERASAKI CIRCUIT BREAKERS (S) PTE. LTD.

17 Tuas Street Singapore 638454

TEL +65-6744-9752

FAX +65-6748-7592

tecs@tecs.com.sg